

# AKAI SERVICE MANUAL

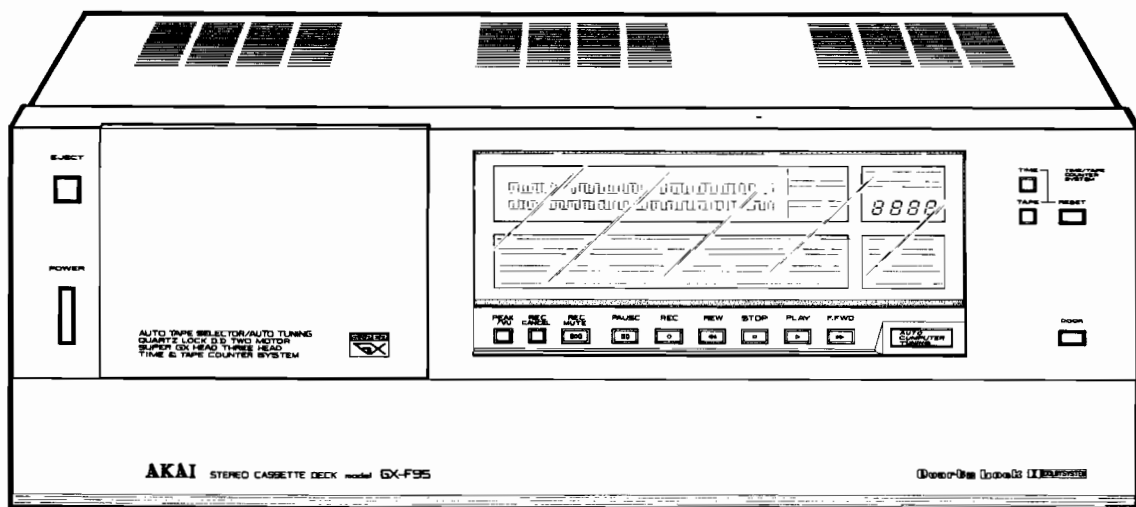

STEREO CASSETTE DECK

MODEL **GX-F95**



## STEREO CASSETTE DECK

# MODEL GX-F95

THIS MODEL IS APPLICABLE TO BOTH SILVER AND BLACK PANEL MODELS

SECTION 1	SERVICE MANUAL .....	3
SECTION 2	PARTS LIST .....	71
SECTION 3	SCHEMATIC DIAGRAM .....	88

---

---

---

SECTION 1

**SERVICE MANUAL**

TABLE OF CONTENTS

<b>I.</b>	<b>SPECIFICATIONS</b> .....	<b>4</b>
<b>II.</b>	<b>DISMANTLING OF UNIT</b> .....	<b>5</b>
<b>III.</b>	<b>CONTROLS</b> .....	<b>6</b>
<b>IV.</b>	<b>PRINCIPAL PARTS LOCATION</b> .....	<b>7</b>
<b>V.</b>	<b>VOLTAGE CONVERSION</b> .....	<b>8</b>
<b>VI.</b>	<b>EXPLANATION OF CIRCUIT ACTIONS</b> .....	<b>9</b>
	1. INTRODUCTION .....	15
	2. SYSTEM DESCRIPTION .....	16
	3. OUTPUT, VOLTAGE AND WAVEFORM ASSOCIATED WITH PINS OF MICROCOMPUTERS .....	16
	4. DIFFERENCES FROM CONVENTIONAL MODELS .....	16
	5. EXPLANATION OF ATS ACTION .....	18
	6. EXPLANATION OF SYSCON CIRCUIT ACTION .....	32
	7. FACTORY REFERENCE TAPE .....	38
	8. SPECIAL COMMENTS .....	38
<b>VII.</b>	<b>MECHANISM ADJUSTMENT</b> .....	<b>39</b>
	1. PLAY PLUNGER INSTALLATION POSITION ADJUSTMENT .....	39
	2. PAUSE PLUNGER INSTALLATION POSITION ADJUSTMENT .....	39
	3. REC LEAF SWITCH INSTALLATION POSITION ADJUSTMENT .....	39
	4. CrO <sub>2</sub> TAPE DETECT LEAF SWITCH INSTALLATION POSITION ADJUSTMENT .....	39
	5. METAL TAPE DETECT LEAF SWITCH INSTALLATION POSITION ADJUSTMENT ..	39
	6. VERIFICATION OF ACTION OF AUTO TAPE SELECTOR .....	41
	7. BRAKE PLUNGER INSTALLATION POSITION ADJUSTMENT .....	41
	8. PINCH ROLLER PRESSURE MEASUREMENT .....	41
	9. WINDING TORQUE MEASUREMENT IN EACH MODE .....	41
<b>VIII.</b>	<b>HEAD ADJUSTMENT</b> .....	<b>42</b>
	1. TAPE GUIDE HEIGHT ADJUSTMENT .....	43
	2. REC/PB COMBINATION HEAD PROJECTION ADJUSTMENT .....	43
	3. REC/PB COMBINATION HEAD HEIGHT ADJUSTMENT .....	43
	4. REC/PB COMBINATION HEAD AZIMUTH ALIGNMENT ADJUSTMENT .....	43
<b>IX.</b>	<b>ELECTRICAL ADJUSTMENT</b> .....	<b>44</b>
	1. DC VOLTAGE ADJUSTMENT .....	44
	2. CAPSTAN MOTOR PHASE ADJUSTMENT .....	44
	3. PHOTO COUPLER LEVEL ADJUSTMENT .....	45
	4. PRE AMPLIFIER ADJUSTMENT .....	49
	5. BAR METER ADJUSTMENT .....	51
	6. AUTO TUNING ADJUSTMENT .....	52
<b>X.</b>	<b>DC RESISTANCE OF VARIOUS COILS</b> .....	<b>53</b>
<b>XI.</b>	<b>CLASSIFICATION OF VARIOUS P.C BOARDS</b> .....	<b>53</b>
	1. P.C BOARD TITLE AND IDENTIFICATION NUMBERS .....	53
	2. COMPOSITION OF VARIOUS P.C BOARDS .....	54

For basic adjustments, measuring methods, and operating principles, refer to GENERAL TECHNICAL MANUAL.



# I. SPECIFICATIONS

TRACK SYSTEM	4 Track 2 Channel Stereo System
TAPE	Phillips Tape Cassette
TAPE SPEED	4.76 cm/s $\pm$ 0.2% (1-7/8 ips. $\pm$ 0.2%)
HEADS	Erase head $\times$ 1 Super GX head for recording $\times$ 1 Super GX head for playback $\times$ 1
MOTORS	Quartz Locked PLL servo DC motor for capstan drive (Direct drive) $\times$ 1 DC motor for reel drive $\times$ 1 DC motor for door opening $\times$ 1
WOW & FLUTTER	Less than 0.028% WRMS, 0.07% (DIN 45500)
TAPE WINDING TIME	60 sec. using a C-60 cassette tape
FREQUENCY RESPONSE	Normal: 20 to 16,000 Hz $\pm$ 3 dB (-20 VU) CrO <sub>2</sub> : 20 to 18,000 Hz $\pm$ 3 dB (-20 VU) Metal: 20 to 21,000 Hz $\pm$ 3 dB (-20 VU)
SIGNAL TO NOISE RATIO	Normal: Better than 60 dB CrO <sub>2</sub> : Better than 61 dB Metal: Better than 62 dB (measured via tape with peak recording level) Dolby NR switch ON: Improves up to 10 dB above 5 kHz
HARMONIC DISTORTION	Normal: Less than 0.7% CrO <sub>2</sub> : Less than 0.6% Metal: Less than 0.6%
INPUT	MIC: 0.25 mV (input impedance 5.0 kohms) Required microphone impedance: 600 ohms Line: 70 mV (input impedance 47 kohms)
OUTPUT	Line: 410 mV at 0 VU Required load impedance: more than 20 kohms Phone: 100 mV/8 ohms at 0 VU
DIN	Input: 2 mV (input impedance 2 kohms) Output: 410 mV Required load impedance: more than 20 kohms
POWER REQUIREMENTS	100V, 50/60 Hz for Japan 120V, 60 Hz for USA and Canada 220V, 50 Hz for Europe except UK 240V, 50 Hz for UK and Australia 110V/120V/220V/240V, 50/60 Hz switchable for other countries.
POWER CONSUMPTION	JPN 41W CSA, AAL 46W
DIMENSIONS	440(W) $\times$ 164(H) $\times$ 364(D) mm (17.3 $\times$ 6.5 $\times$ 14.3")
WEIGHT	12.5 kg (27.5 lbs)

\* For improvement purposes, specifications and design are subject to change without notice.

\* "Dolby" and the Double D symbol are trademarks of Dolby Laboratories.  
(Manufactured under license from Dolby Laboratories).

## II. DISMANTLING OF UNIT

In case of trouble, etc. necessitating dismantling, please dismantle in the order shown in the photographs. Reassemble in reverse order.

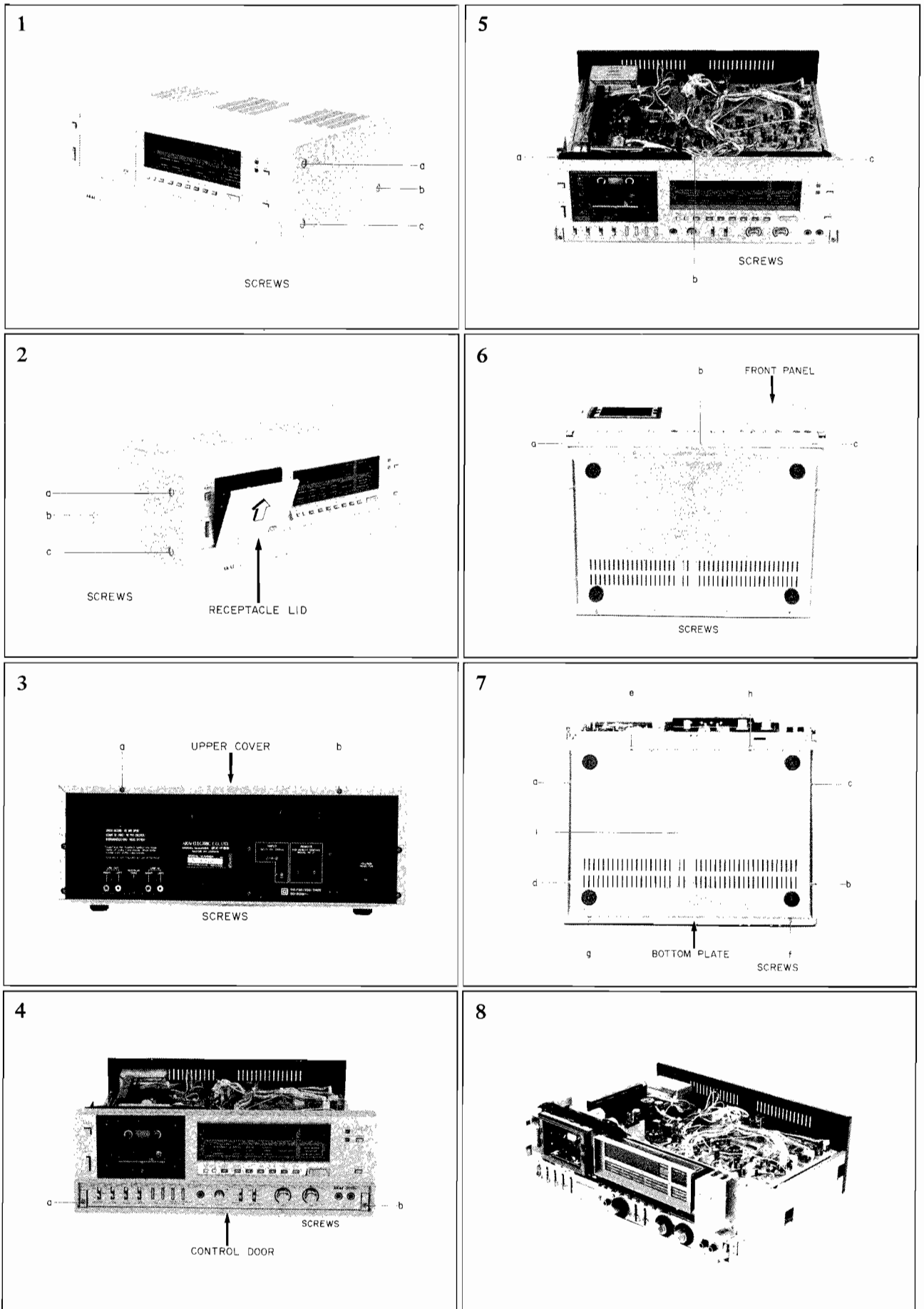

### III. CONTROLS

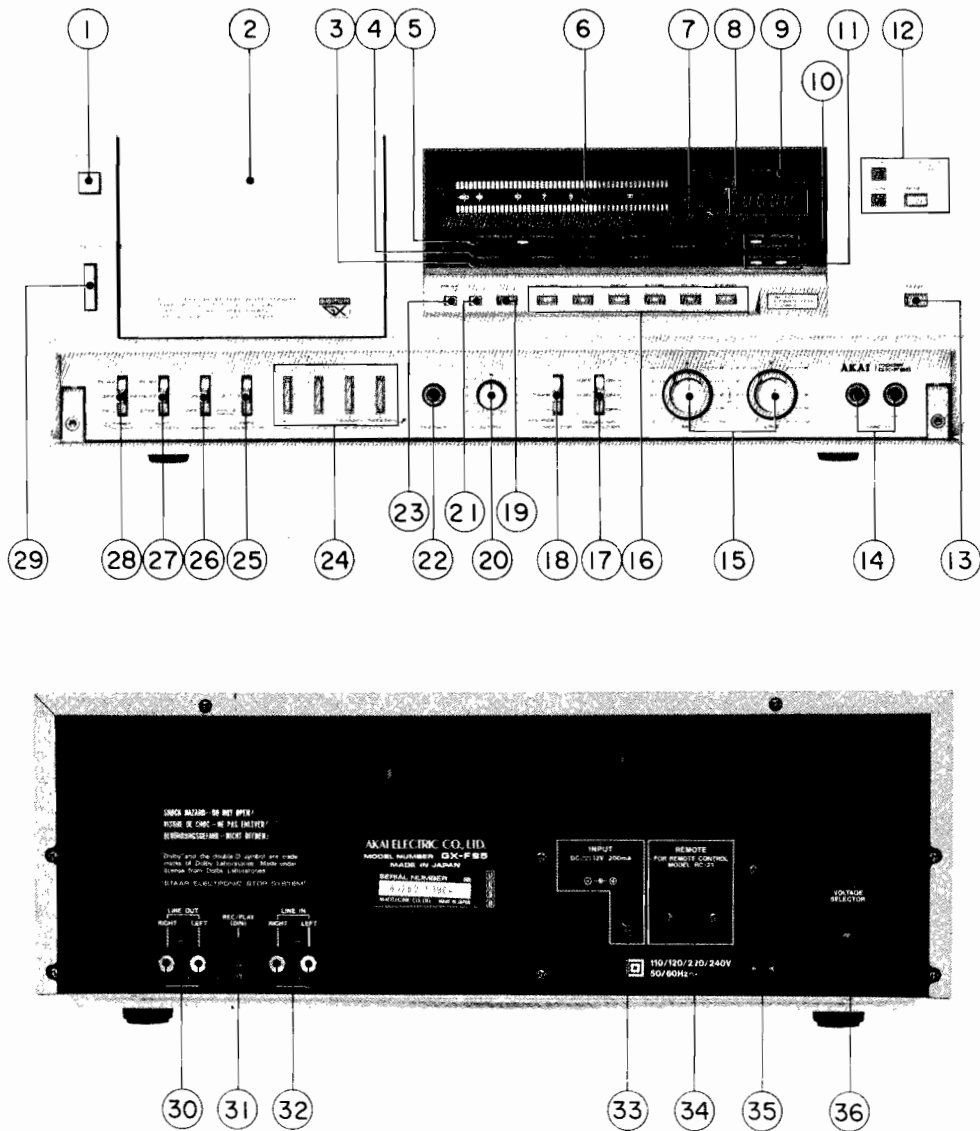

Fig. 1 Controls

- |                                                                                      |                                                                     |
|--------------------------------------------------------------------------------------|---------------------------------------------------------------------|
| 1. EJECT BUTTON                                                                      | 20. OUTPUT CONTROL                                                  |
| 2. CASSETTE RECEPTACLE<br>(See through-cassette lid is standard accessory.)          | 21. RECORDING (REC) CANCEL BUTTON                                   |
| 3. MEMORY and TUNING MEMORY INDICATORS                                               | 22. HEADPHONE JACK (PHONES)                                         |
| 4. AUTO TUNING INDICATORS                                                            | 23. PEAK/VU SELECTOR                                                |
| 5. REFERENCE and REFERENCE TAPE INDICATORS                                           | 24. AUTO TUNING MODE SELECTOR                                       |
| 6. FLD BAR METER WITH MAXIMUM HOLD                                                   | 25. TAPE SELECTOR                                                   |
| 7. PEAK and VU INDICATORS                                                            | 26. MEMORY SELECTOR                                                 |
| 8. TIME/TAPE COUNTER                                                                 | 27. AUTO SYSTEM SELECTOR                                            |
| 9. MEMORY INDICATOR                                                                  | 28. TIMER START SELECTOR                                            |
| 10. TAPE MONITOR INDICATORS                                                          | 29. POWER SWITCH                                                    |
| 11. DOLBY NR and MPX FILTER INDICATORS                                               | 30. LINE IN JACKS (RIGHT and LEFT)                                  |
| 12. TIME/TAPE COUNTER SYSTEM                                                         | 31. DIN JACK<br>(Some models do not have this facility.)            |
| 13. DOOR BUTTON                                                                      | 32. LINE OUT JACKS (RIGHT and LEFT)                                 |
| 14. MICROPHONE JACKS (Left-MIC-Right)                                                | 33. INPUT JACK                                                      |
| 15. MICROPHONE (MIC) and LINE RECORDING<br>LEVEL CONTROLS (Left $\rightarrow$ Right) | 34. REMOTE CONTROL JACK                                             |
| 16. OPERATING BUTTONS                                                                | 35. AC INLET<br>(Some models are equipped with an AC Cord instead.) |
| 17. DOLBY NR and MPX FILTER SWITCH                                                   | 36. VOLTAGE SELECTOR<br>(Some models do not have this facility.)    |
| 18. TAPE MONITOR SELECTOR                                                            |                                                                     |
| 19. RECORDING (REC) MUTE BUTTON (  •  )                                              |                                                                     |

# IV. PRINCIPAL PARTS LOCATION

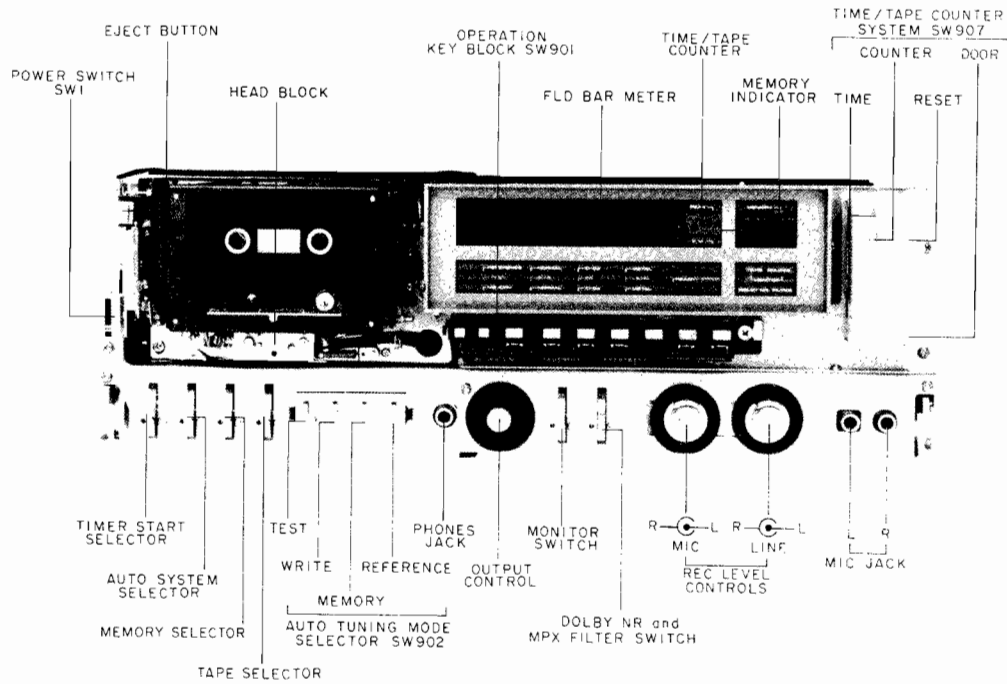

Fig. 2 Front View

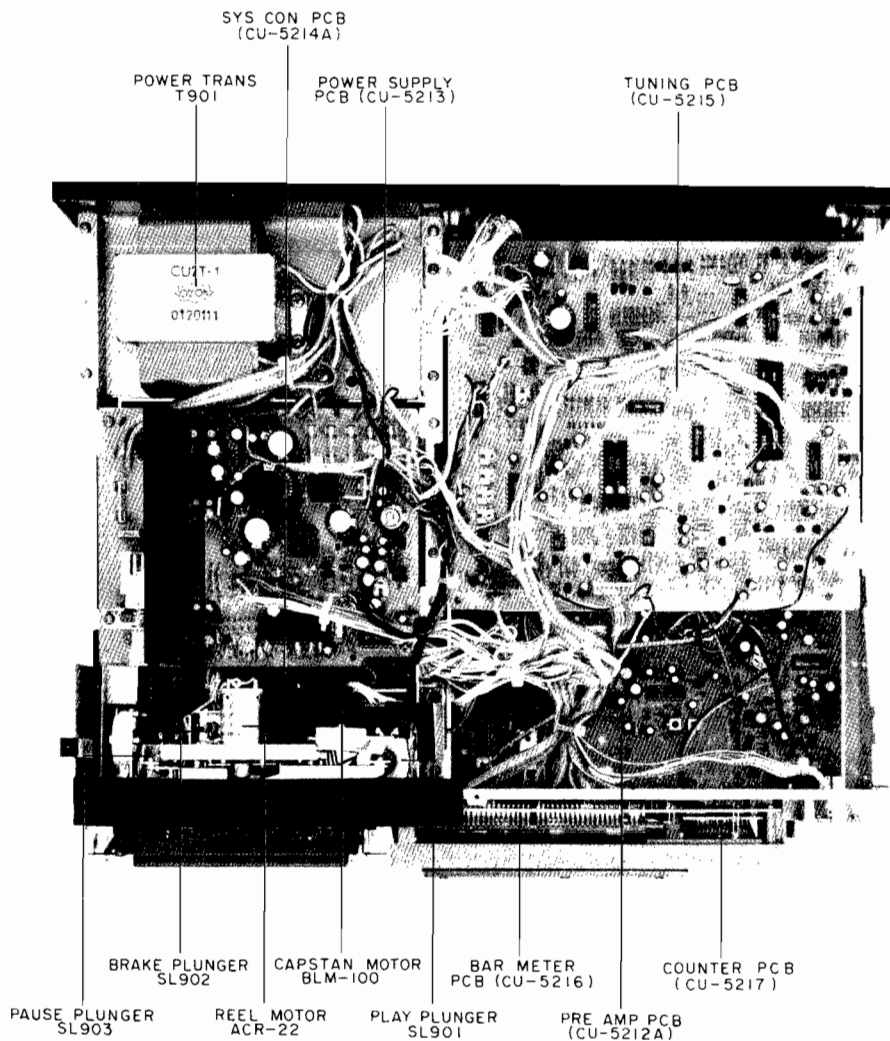

Fig. 3 Top View

# V. VOLTAGE CONVERSION

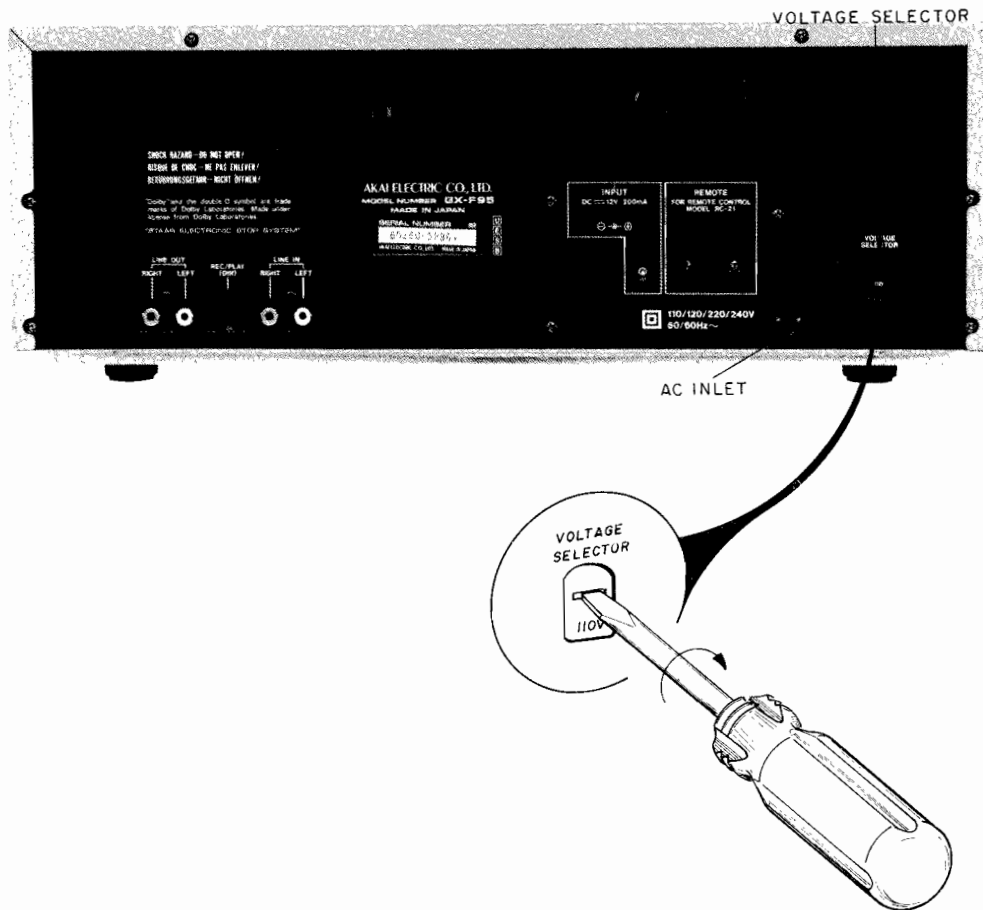

Fig. 4 Rear View (U/T, CEE, UK, SAA Models)

## 1. JPN, CAS, AAL Model

No Voltage conversion.

## 2. U/T, CEE, UK, SAA Model (Refer to Fig. 4)

Turn the Voltage selector on the rear panel to the right with a minus screwdriver, as shown in Fig. 4, to obtain 110V, 120V, 220V, 240V successively. All you have to do is match the voltage you want with the voltage indicated. Fuse change is not necessary.

**CAUTION:** When converting voltage turn off the power switch and unplug the power cord.

# VI. EXPLANATION OF CIRCUIT ACTIONS

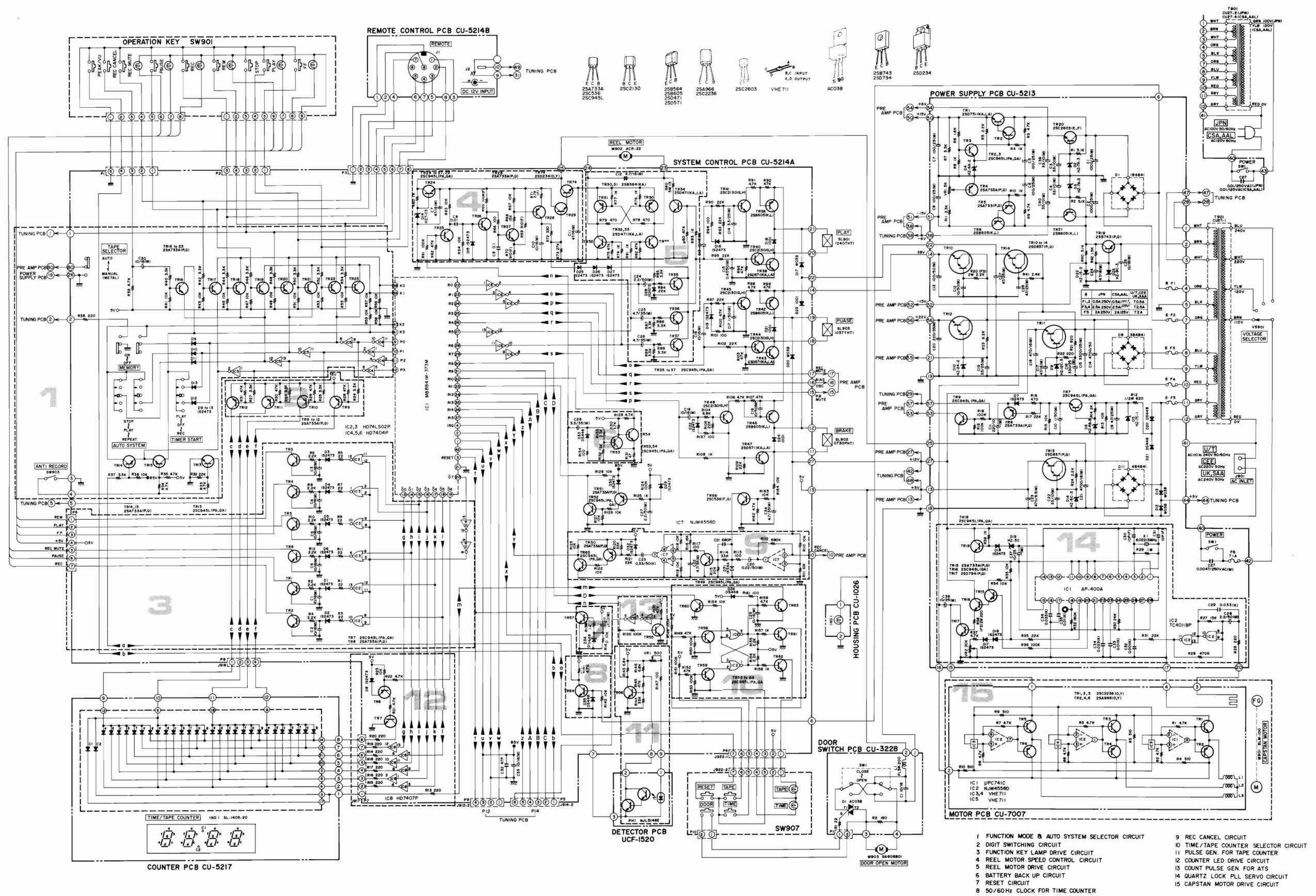

Fig. 5 Power Supply & Syscon Schematic Diagram

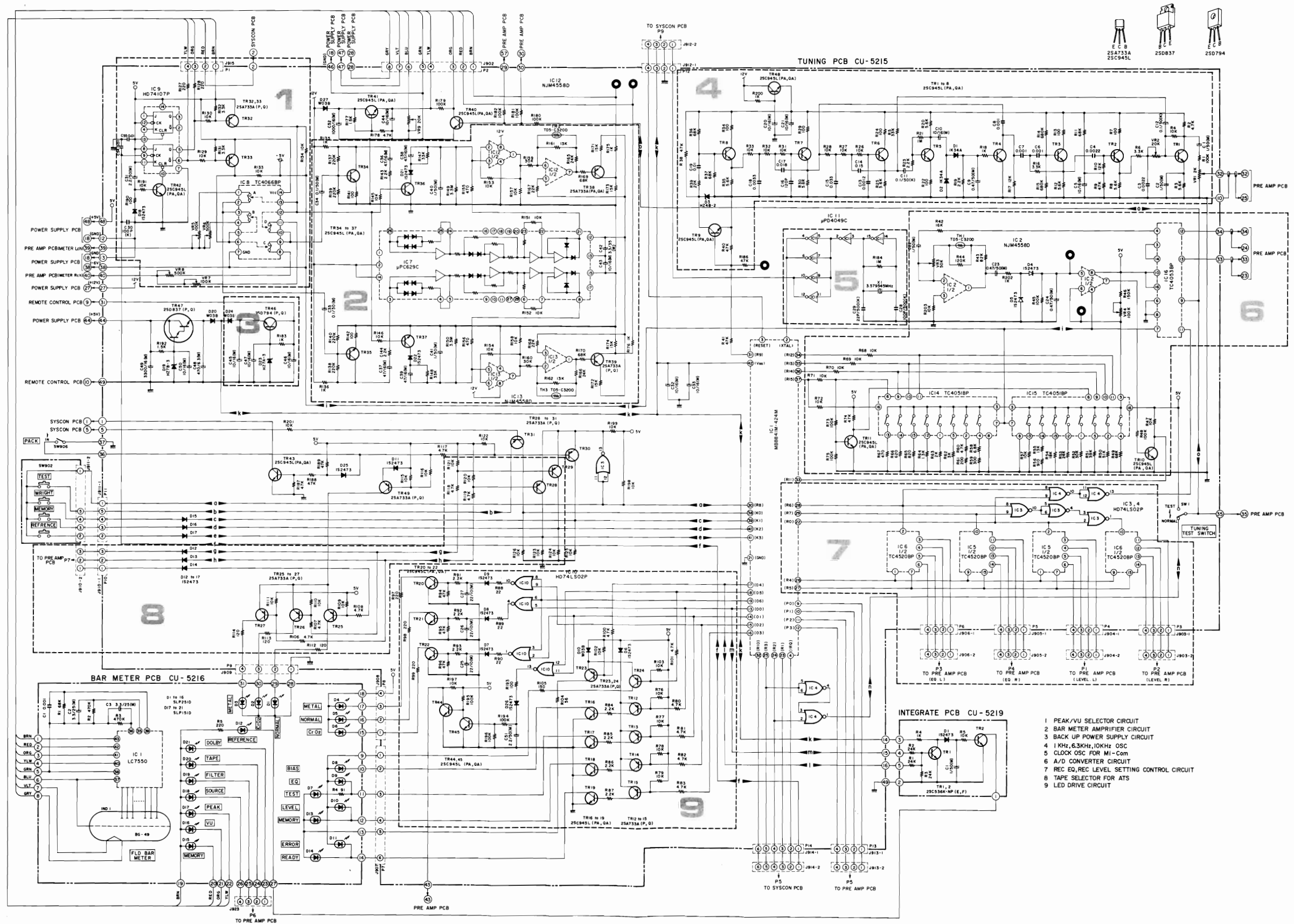

Fig. 6 Auto Tuning Schematic Diagram

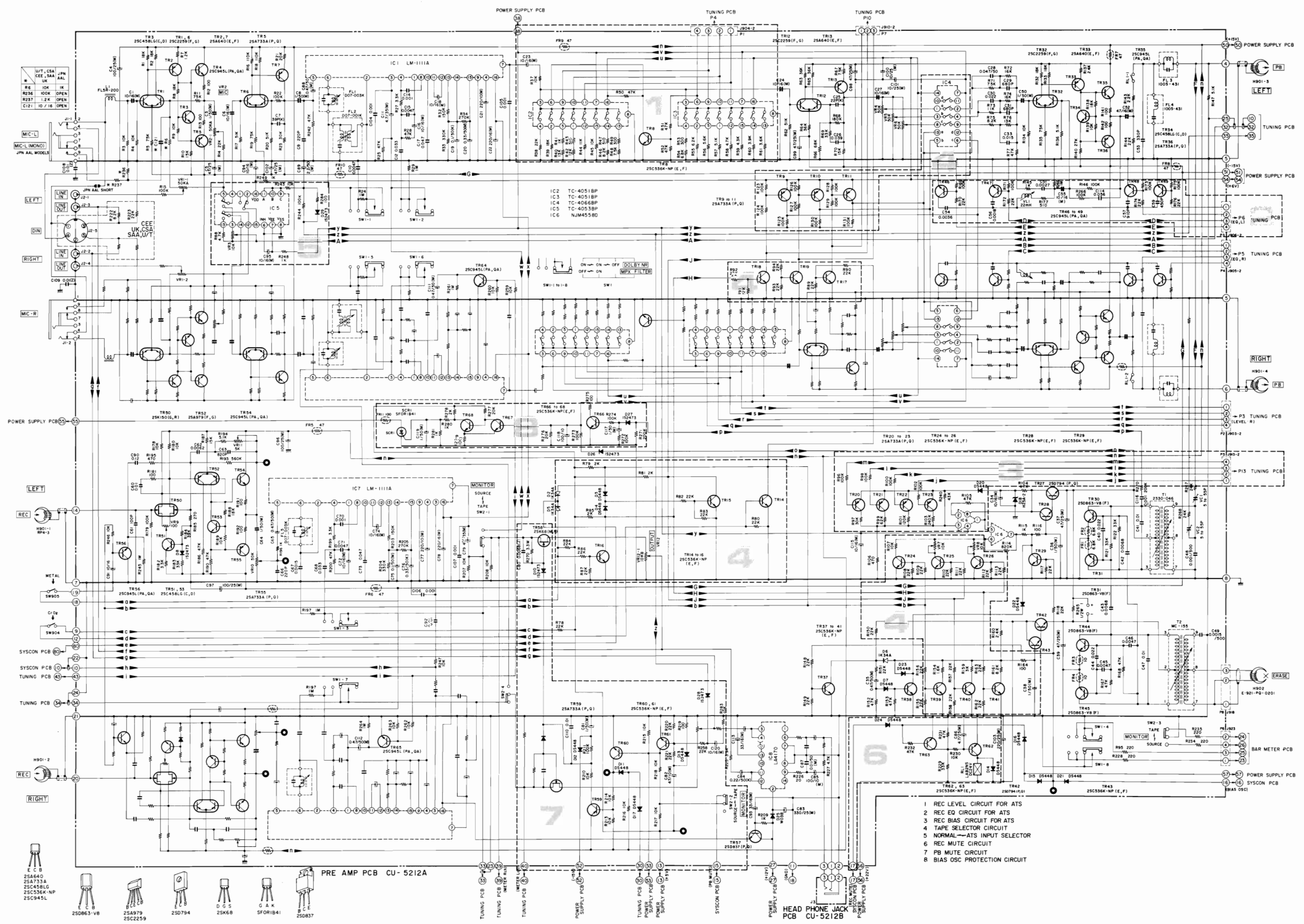

Fig. 7 Amplifier Schematic Diagram



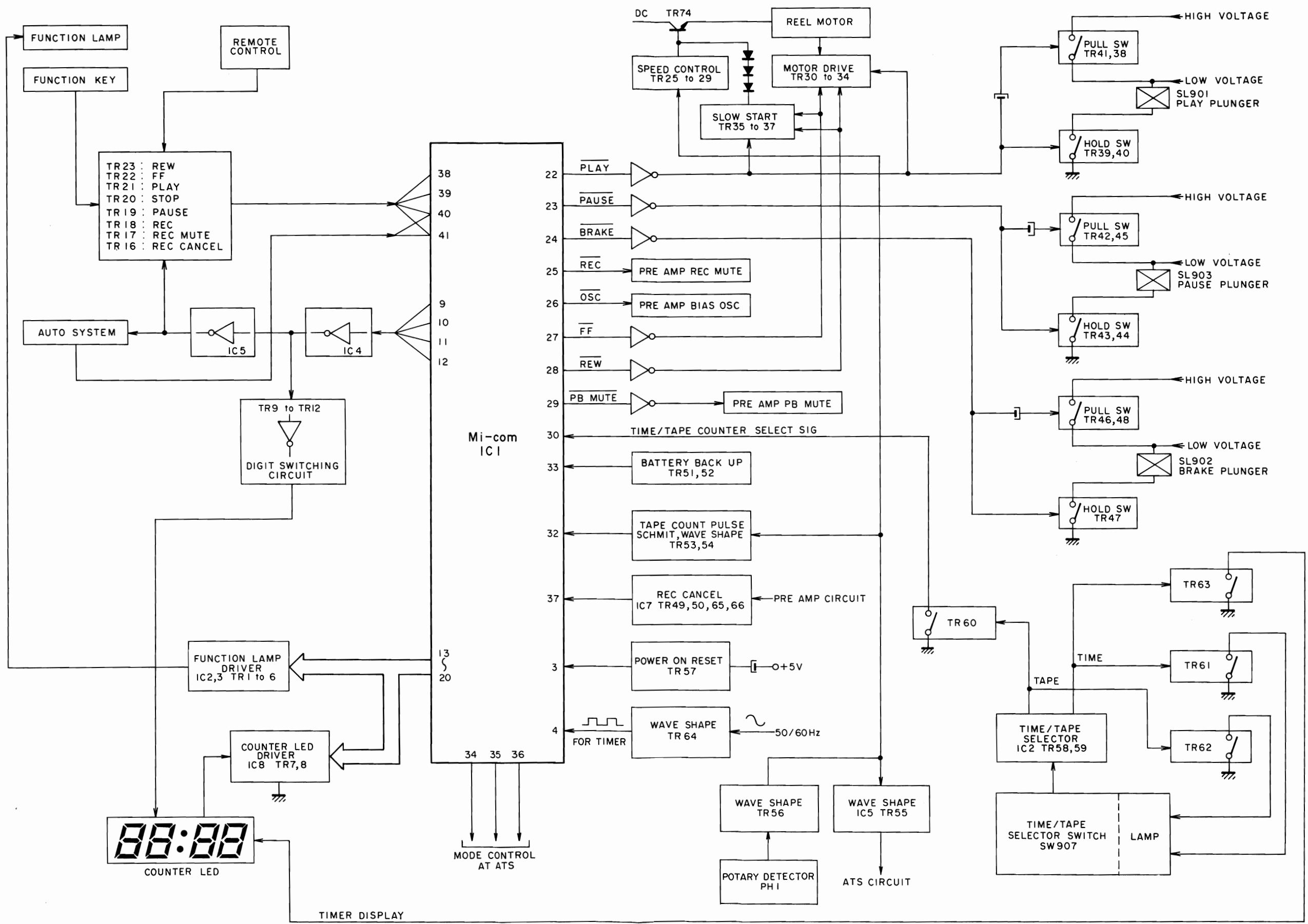

Fig. 8 Syscon Block Diagram

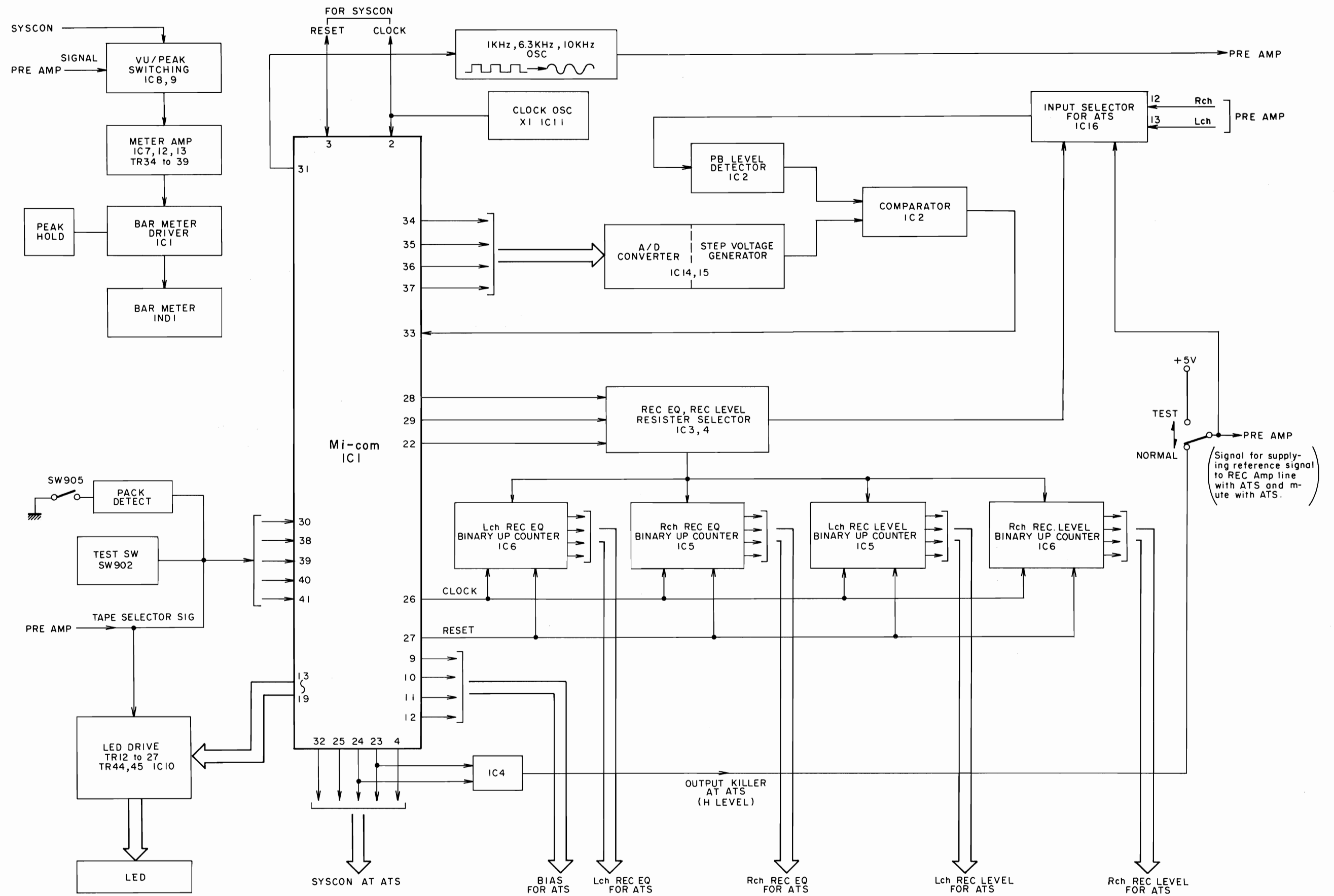

Fig. 9 Auto Tuning System Block Diagram

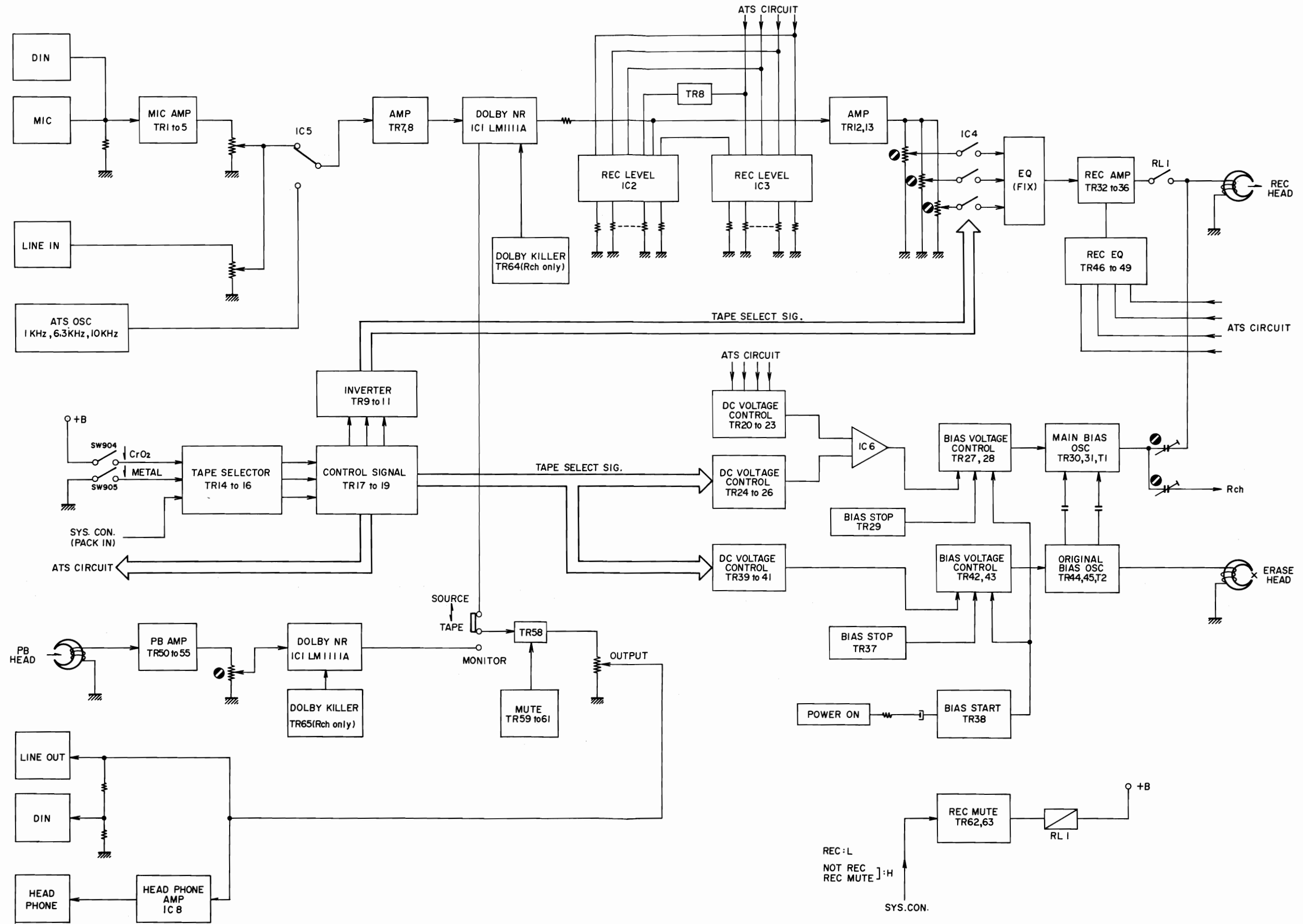

Fig. 10 Amplifier Block Diagram

## 1. INTRODUCTION

The GX-F95 is a 3-head type cassette deck with many excellent features. Being one of the most sophisticated machine, the GX-F95 is the result of newly developed technology coupled with many years of experience and know-how with many models that precede the GX-F95.

With this in mind, this document is intended to provide technical explanations in the form of supplements through comparison with the conventional models (often with the GX-F90).

The GX-F95 basically differs from the conventional machines (e.g., GX-F90) in that:

- 1) it incorporates the microcomputer-based ATS (Auto Tuning System) circuit which permits setting of the optimum bias, Rec EQ and Rec level in accordance with the characteristics of tape in use.
- 2) it also has a microcomputer incorporated in the system control circuit to provide control over the timing of operation.
- 3) it employs a capstan motor that is driven directly by the quartz-lock PLL servo circuit.
- 4) it incorporates direct coupled (DC) over the recording amplifier.

## 2. SYSTEM DESCRIPTION

### 1) ATS (Auto Tuning System) Circuit

ATS permits automatic identification of tape type by the use of a built-in microcomputer and determines the optimum bias, Rec EQ and Rec level for that particular type of tape in use.

Types of cassette tape currently available on the market include metal tape, CrO<sub>2</sub> tape, LH tape and LN tape: the types of tapes available will be innumerable if the fact that tape characteristics often differ from one tape manufacturer to another is taken into account.

To cope with this situation, ATS provides a means of making full use of the characteristics of a specific type of tape and thereby ensuring recording and playback under optimum conditions.

ATS has a microcomputer which instantly analyzes the characteristics of individual tapes and informs the tape deck of the optimum bias, Rec EQ and Rec level.

The ATS incorporated in the GX-F95 is specifically designed to provide for separate right-left double tuning in which EQ and Rec levels are tuned twice for each of the right and left channels (the bias is tuned twice for both the right and left channels at the same time).

It also has a mechanism that permits automatic fast-forwarding of the starting portion of the tape where the tape characteristic tends to fluctuate at the time of tuning. Fig. 11 shows the flow chart for the ATS.

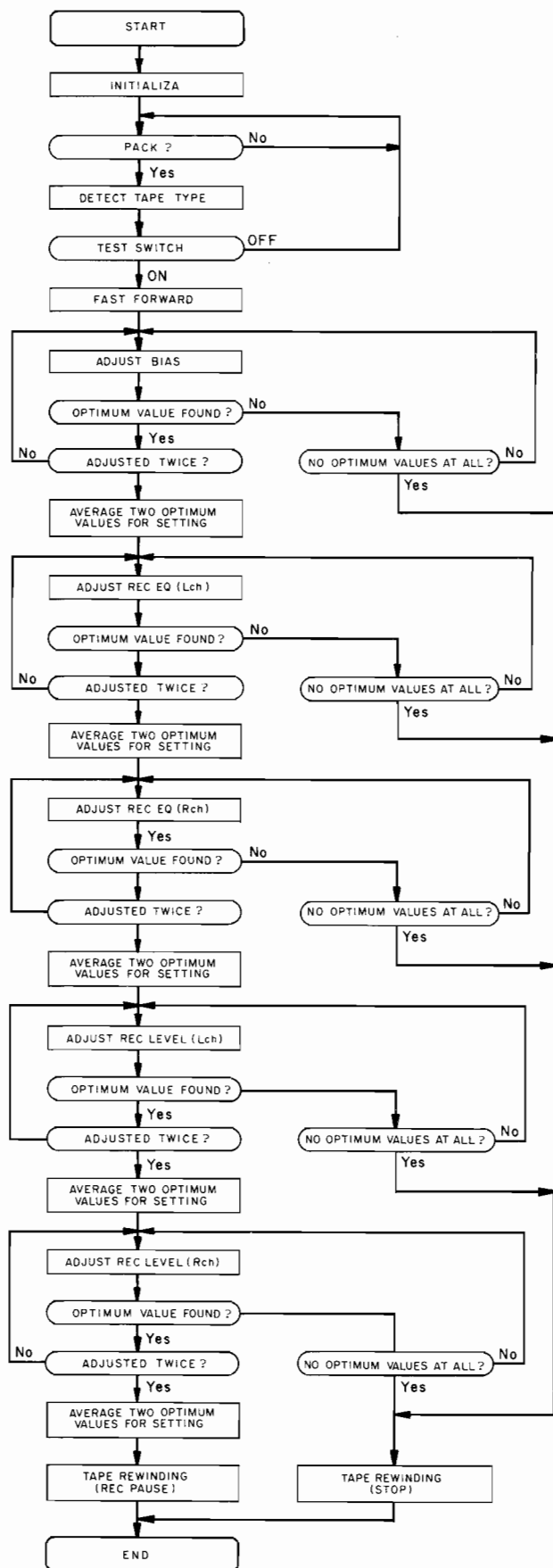

Fig. 11 Auto Tuning Flow Chart

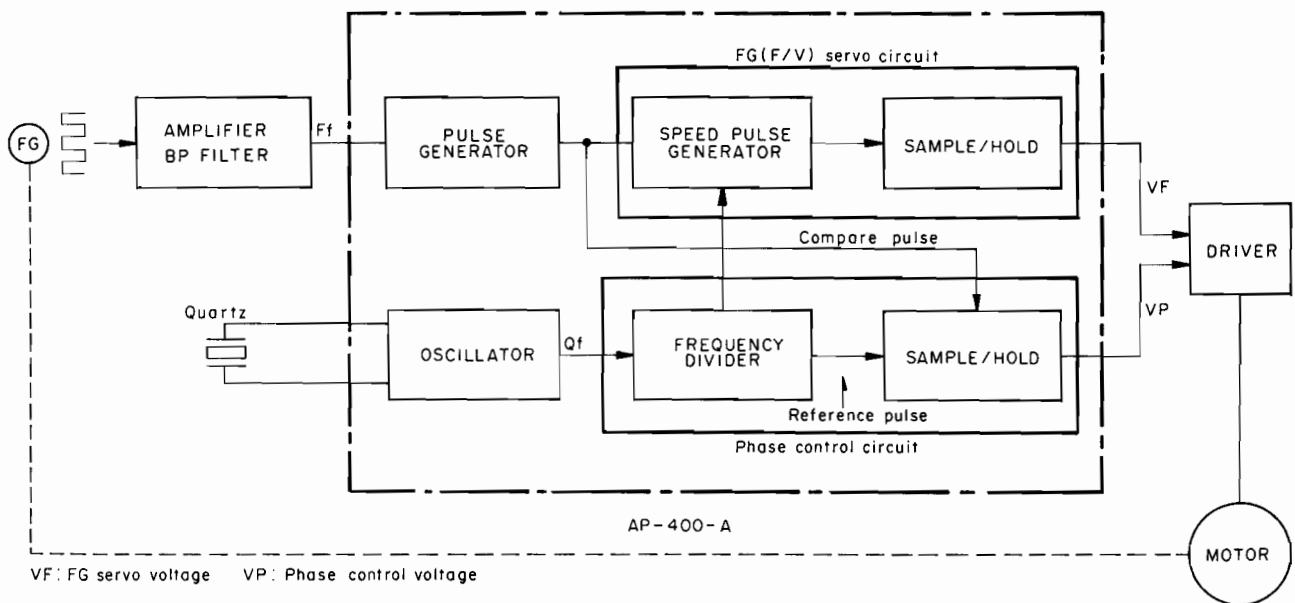

Fig. 12 Block Diagram of Quartz Lock PLL Servo Circuit

## 2) Timing of Operation

Various improvements in performance can be achieved by the use of a microcomputer to control the operational timing of each function. For example, a noise problem often encountered upon "rise" can be solved by controlling the timing of record/playback operation with a microcomputer. In addition, use of a microcomputer can virtually eliminate the possibility of degradation in performance due to wear since most of the mechanical switching mechanisms required formerly are no longer necessary with microcomputers.

## 3) Quartz-Lock D.D System

With the GX-F95, to ensure high rotational accuracy, phase control is effected through quartz oscillation (known as quartz lock).

Coupled with the high-performance direct drive mechanism employed on the GX-F90, this quartz lock system helps to maintain extremely high rotational accuracy from the start to the end of tape winding.

See the Model GX-F90 and AP-Q50 Manuals for the operating principle of the motor and the action of the quartz-lock servo circuit.

## 4) Direct Coupled (DC) Recording Amplifier

To enhance the quality of sound, it is necessary to employ high-performance amplifiers. The recording amplifier incorporated in the GX-F95 features direct coupled (DC) to minimize distortion at recording time.

For the playback amplifier, dual FET is adopted, and other improvements are also incorporated in amplifier circuitry.

## 3. OUTPUT, VOLTAGE AND WAVEFORM ASSOCIATED WITH PINS OF MICROCOMPUTERS

Outputs of a microcomputer can be either "1(H)" or "0(L)" in a given mode as with conventional digital ICs, or they can be produced based on timing between two or more pulse waveforms. They even may vary depending on the type of tape in use. Thus, it is generally necessary to conduct waveform check with the use of an oscilloscope, etc.

With the microcomputer employed for ATS, the state of 4-bit signals (e.g., 0011) for each of bias, level and EQ outputs varies depending on the type of tape in use. For this reason, circuit diagrams in this manual give only typical outputs as reference outputs.

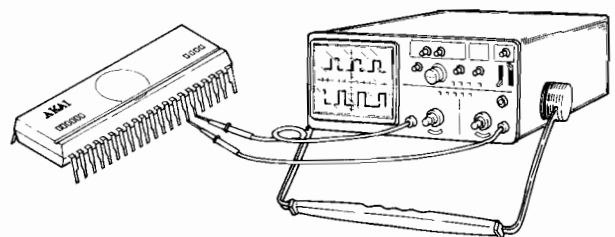

## 4. DIFFERENCES FROM CONVENTIONAL MODELS

The Differences brought about by the adoption of ATS are illustrated in comparison with a conventional model (GX-F90) in the following block diagrams:

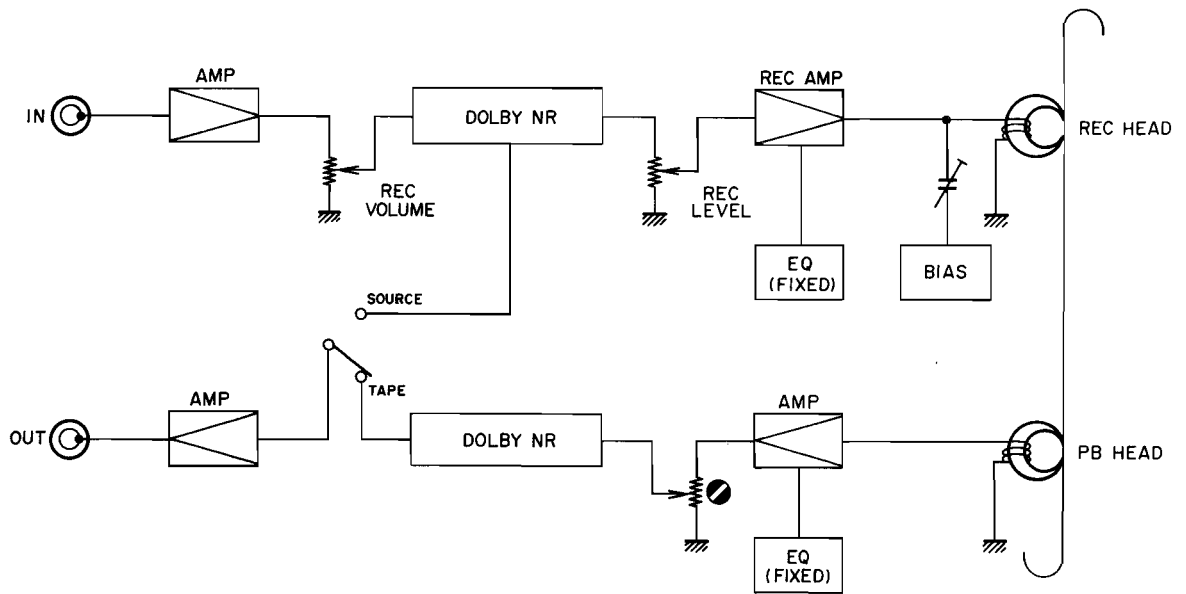

Fig. 13 GX-F90 Amp Block Diagram

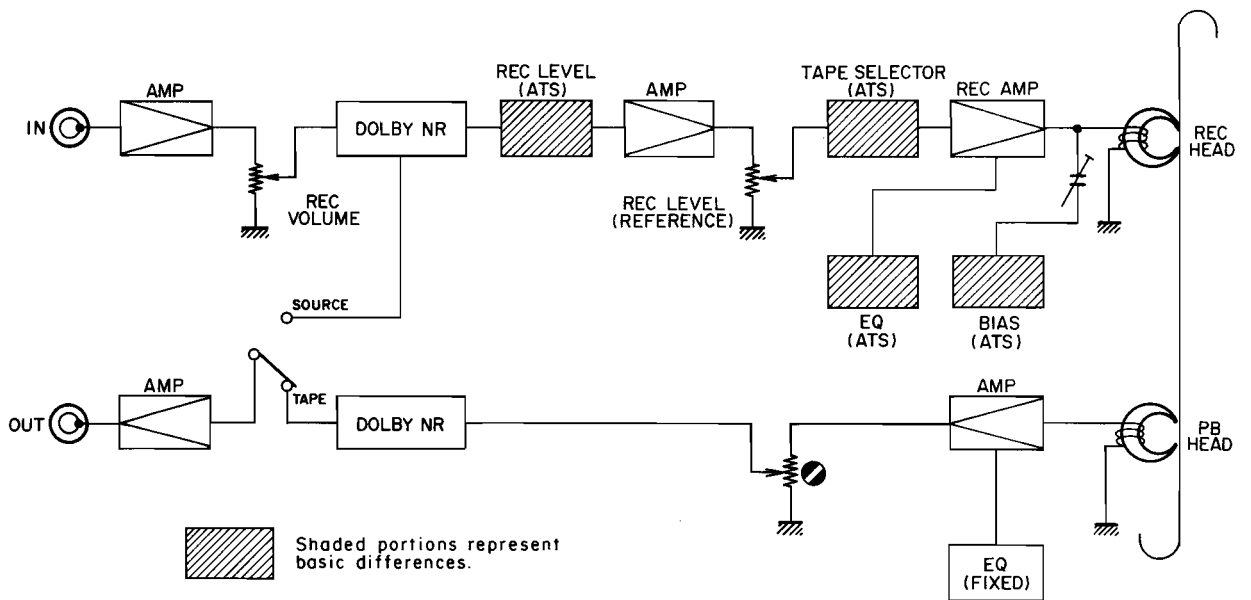

Fig. 14 GX-F95 Amp Block Diagram

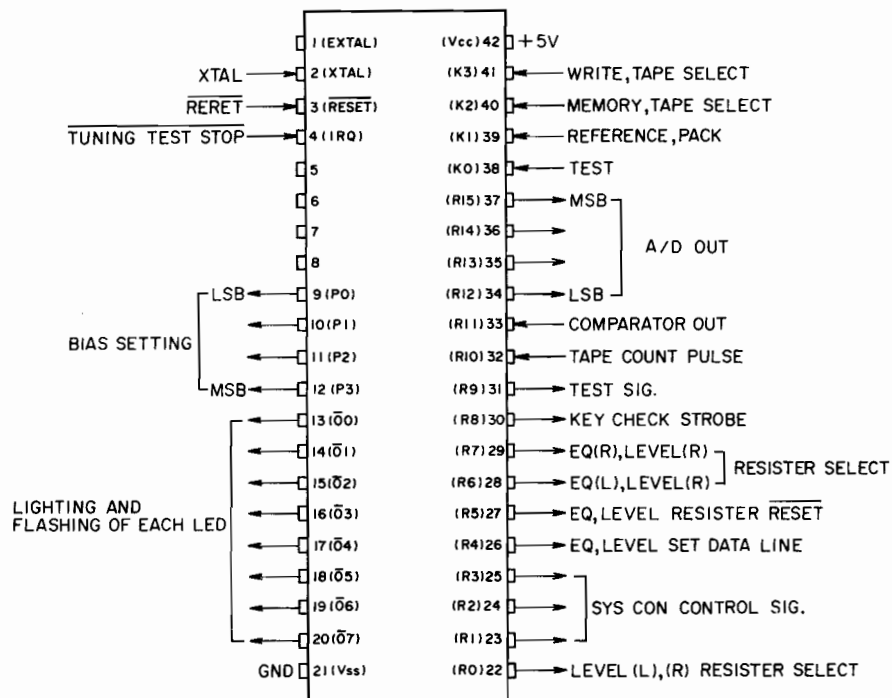

Fig. 15 Terminal Description of ATS Microcomputer

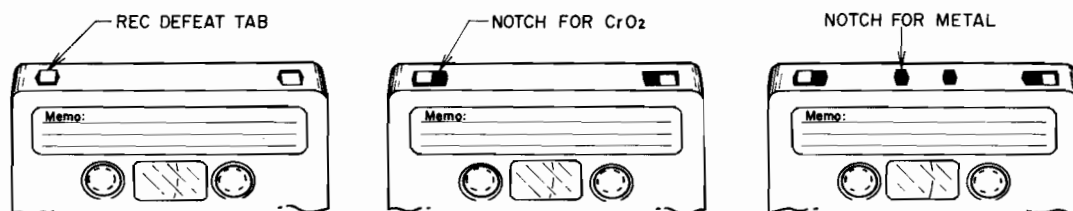

Fig. 16 Cassette Configurations

## 5. EXPLANATION OF ATS ACTION

With ATS, depressing the TEST button on the auto tuning mode selector causes the deck itself to establish the optimum amount of bias, Rec EQ and Rec level automatically. In other words, the vary procedure required to adjust the bias, Rec EQ and Rec level manually with the use of a measuring instrument is carried out within the deck according to the program contained in the microcomputer. The ATS operates in the sequence of:

- 1) Identifying the type of tape (This step is included here for clarity though it does not involve a setting operation as given below.)
  - 2) Setting the Bias
  - 3) Setting the Rec EQ
  - 4) Setting the Rec level
- } (Setting is automatic through depression of the TEST button.)

What has been mentioned above will be discussed in detail in the rest of this section. Fig. 15 shows terminal connections on the microcomputer for ATS (MB8841M-424M).

### 1) Identifying tape types

Upon insertion of a cassette pack, Normal/CrO<sub>2</sub>/Metal identification is made automatically according to the type of cassette in use.

This identification method is, like the one employed to prevent recording, based on the presence/absence of a detection notch as illustrated in Fig. 16. However, some types of metal tape packs lack the detection notch (due partly to their relatively recent introduction into the market) and they require manual setting of the tape selector.

Upon detection of the type of tape in use, the erasing OSC, bias, Rec level, PB EQ and Rec EQ are set in "reference" for each tape type by the internal logic circuitry. Also, signals are sent to LED to display LN, CrO<sub>2</sub> or Metal. Note that at the factory, the bias, EQ and Rec level are adjusted using the appropriate reference tape without operating the ATS.

### 5-1. Setting the Bias, Rec EQ and Rec Level with ATS

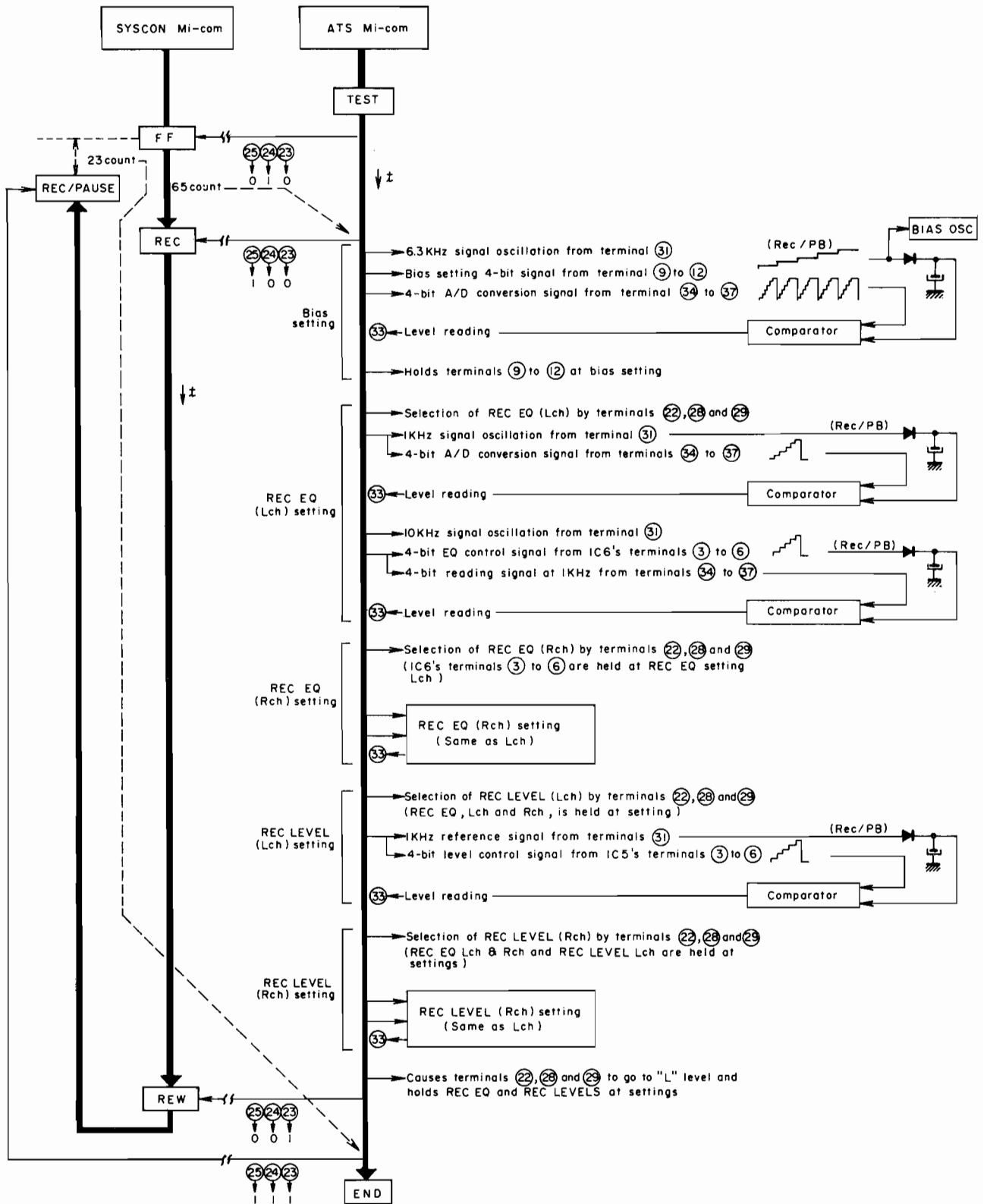

Fig. 17 General Flow of the ATS Operation



With ATS, depressing the TEST button causes the bias, Rec EQ and Rec level to be adjusted in that order.

The signal frequencies and settings involved at this time are as follows:

- (1) Bias: Setting is made with a signal frequency of 6.3 kHz so that the peak bias is exceeded by 3 dB for Normal tape and by 4 dB for Metal and CrO<sub>2</sub> (SA) tape.
- (2) Rec EQ: Setting is made with signal frequencies of 1 kHz and 10 kHz so that the record/playback level with 1 kHz is equal to that with 10 kHz.
- (3) Rec level: Setting is made with 1 kHz so that the input level is equal to the record/playback level.

Fig. 17 shows the general flow of the ATS operation. The following is the explanation of circuits associated with ATS, which is then followed by detailed discussions on bias, Rec EQ and Rec level setting.

These clock pulses are generated by a circuit called a clock oscillator. (See Fig. 18) The clock oscillator produces a clock pulse of 3.579545 MHz which is then supplied to the microcomputer.

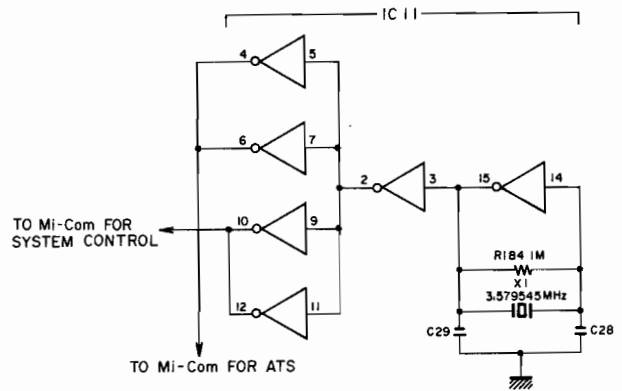

Fig. 18 Clock Oscillator

## 5-2. Clock Oscillator

Commands from and decisions by a microcomputer are all delivered in a specific sequence which is determined by signals known as clock pulses.

## 5-3. Generating ATS Reference Signals (1 kHz, 6.3 kHz and 10 kHz)

Signals of 1 kHz, 6.3 kHz and 10 kHz are required for the setting of the bias, Rec EQ and Rec level with ATS. Fig. 19 shows the circuitry employed for the purpose. The flow of the signals is illustrated below by frequency:

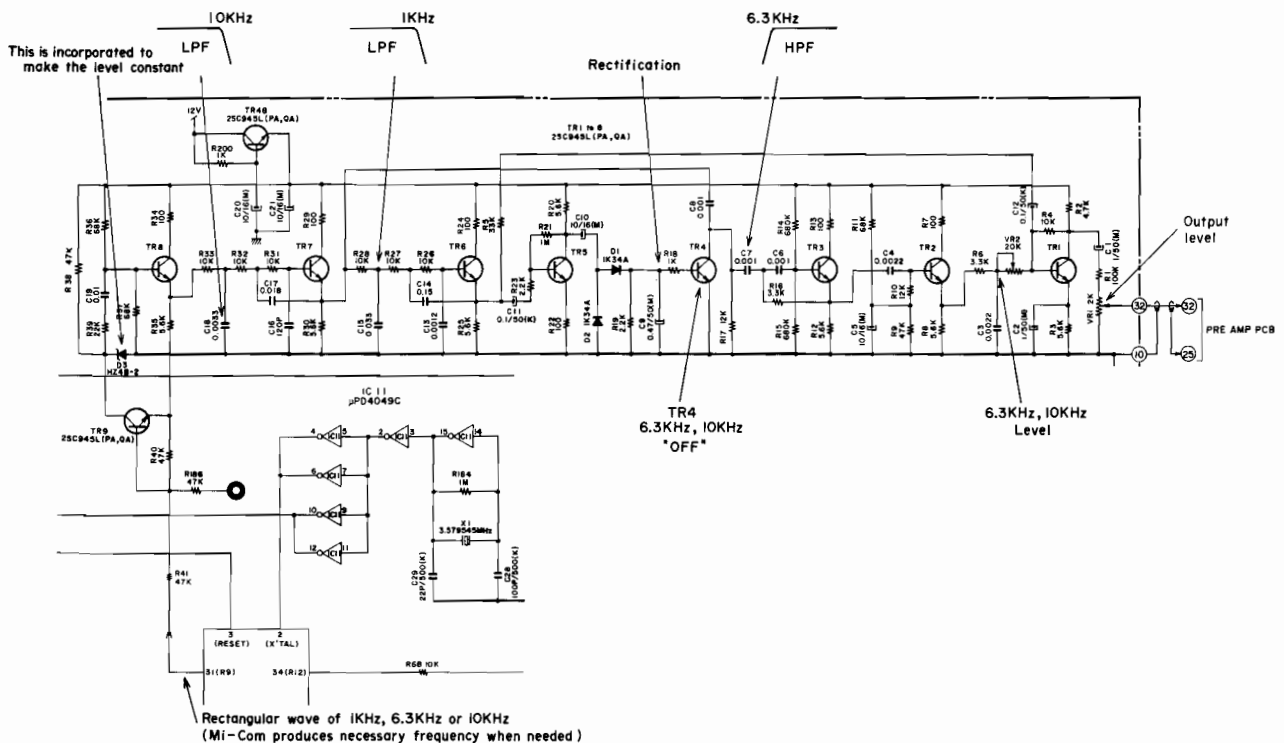

Fig. 19

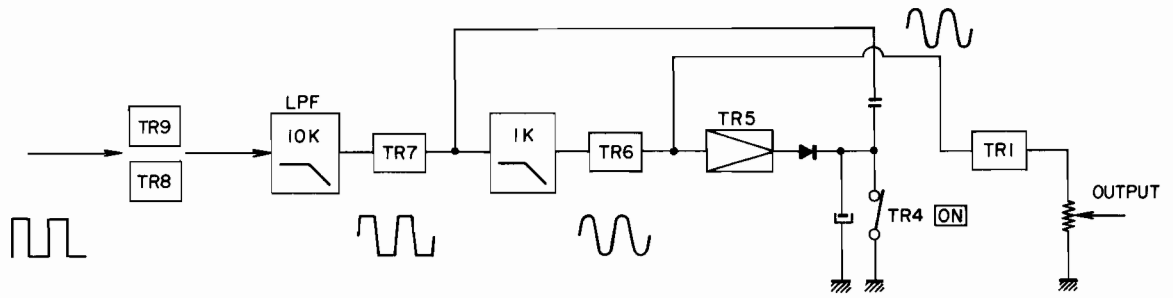

Fig. 20 Flow of 1 kHz-Signal

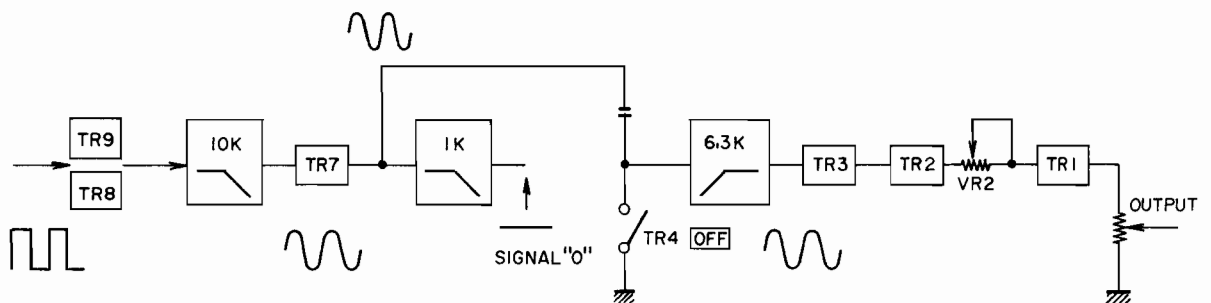

Fig. 21 Flow of 6.3 kHz-Signal

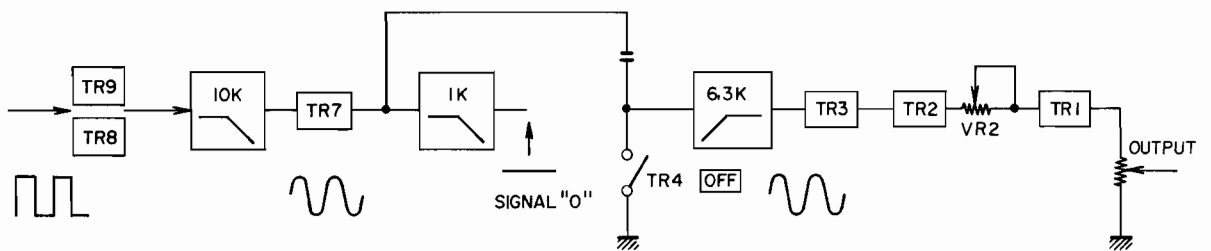

Fig. 22 Flow of 10 kHz-Signal

The microcomputer sends out a rectangular wave which contains "odd" harmonics. The basic sine wave can thus be obtained by removing the harmonics: for example, a rectangular wave of 6.3 kHz contains, in addition to a sine wave of 6.3 kHz, harmonic waves of  $3 \times 6.3$  kHz,  $5 \times 6.3$  kHz and so on, and the sine

wave can be obtained by removing the harmonics. When signals of 6.3 kHz and 10 kHz are passed through HPF (10 kHz), the 10 kHz-signal level drops significantly while the 6.3 kHz-signal level does not: to raise the 10 kHz signal level, a circuit is provided between TR2 and TR3.

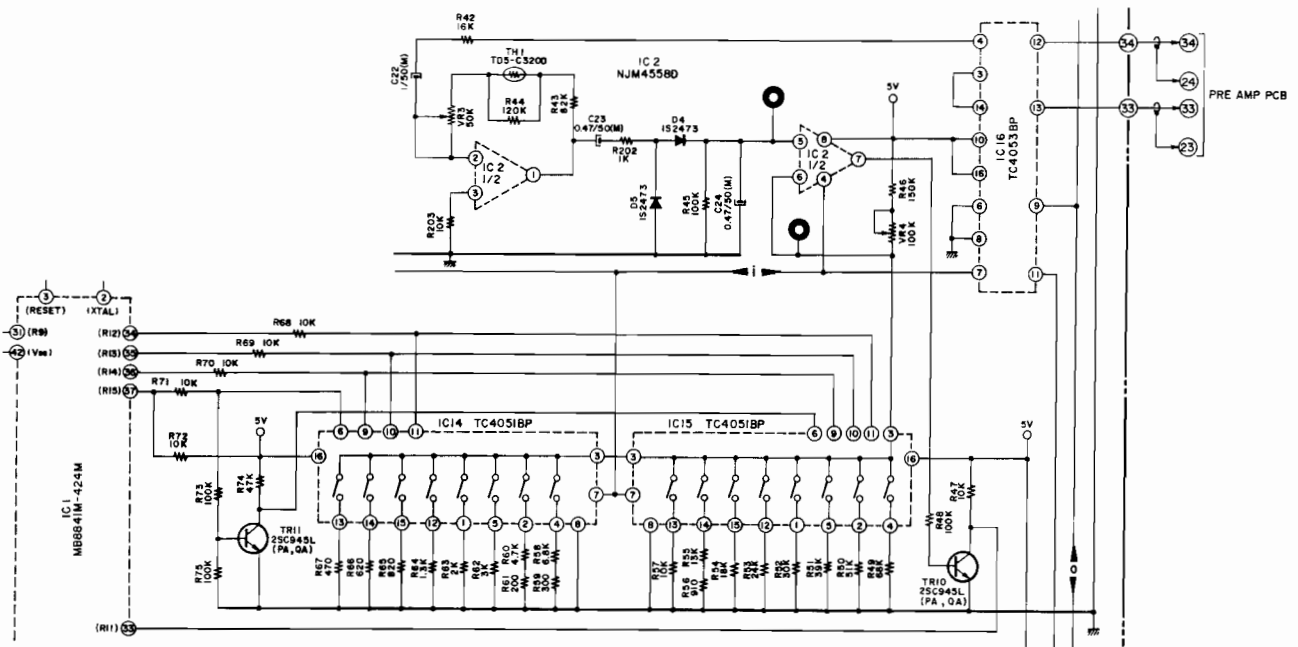

Fig. 23

#### 5-4. Reading Signal Levels with ATS

The microcomputer employed with ATS is responsible for detecting record/playback signal levels. To adjust Rec EQ so that a flat frequency characteristic can be obtained at 1 kHz and 10 kHz, it is necessary to determine first the actual level of the 1 kHz-signal and then that of the 10 kHz signal.

The circuit used for this purpose is illustrated in Fig. 23, the action of which is described below:

- 1) The reproduced signal is supplied to ⑫ of IC16 (L-ch) or to ⑬ of IC16 (R-ch) from the Pre Amp PCB. The L-ch or R-ch signal (switching between L-ch and R-ch is done with the input to ⑪ of IC16) from ④ of IC16 is applied to ② of IC2 and, after leaving IC2 through ①, is converted to DC by D4, D5, C24, etc.
- 2) ⑤, ⑥ and ⑦ of 1/2 IC2 make up a comparator. The relationship given in Fig. 24 may be expressed in terms of waveform as shown in Fig. 25.
- 3) Supplied to ⑥ of IC2 is the step-like reference voltage which is generated by IC14, IC15, Microcomputer, TR11 and resistors connected to them. Fig. 26 illustrates the generation of the step-like reference voltage. Moving the switch (SW) in the direction shown causes various levels of voltage to be generated at TP2 as +5V is divided by R46, VR4 and R67, R66 . . . or R49. The actual switching between IC14 and IC15 is effected by controlling TR11, IC14 and IC15 with signals delivered from the microcomputer. The relationship between signals from the microcomputer and the action of IC's 14 and 15 is shown below:

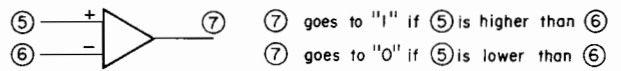

Fig. 24

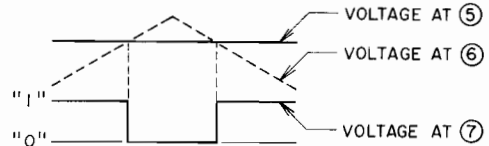

Fig. 25

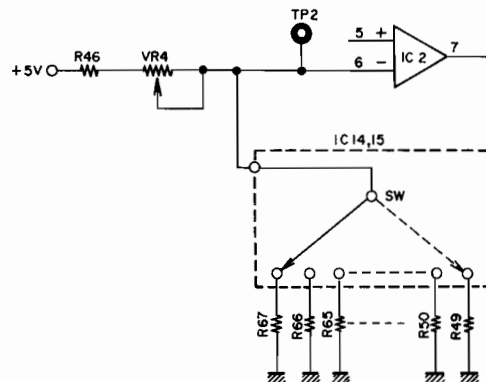

Fig. 26

Mi-Com outputs				IC14				IC15				Terminal connection	
③④	③⑦	③⑥	③⑤	⑥	①①	①⑩	⑨	⑥	①①	①⑩	⑨	IC14	IC15
0	0	0	0	0	0	0	0	1	0	0	0	13	X
0	0	0	1	0	0	0	1	1	0	0	1	14	X
0	0	1	0	0	0	1	0	1	0	1	0	15	X
0	0	1	1	0	0	1	1	1	0	1	1	12	X
0	1	0	0	0	1	0	0	1	1	0	0	1	X
0	1	0	1	0	1	0	1	1	1	0	1	5	X
0	1	1	0	0	1	1	0	1	1	1	0	2	X
0	1	1	1	0	1	1	1	1	1	1	1	4	X
1	0	0	0	1	0	0	0	0	0	0	0	X	13
1	0	0	1	1	0	0	1	0	0	0	1	X	14
1	0	1	0	1	0	1	0	0	0	1	0	X	15
1	0	1	1	1	0	1	1	0	0	1	1	X	12
1	1	0	0	1	1	0	0	0	1	0	0	X	1
1	1	0	1	1	1	0	1	0	1	0	1	X	5
1	1	1	0	1	1	1	0	0	1	1	0	X	2
1	1	1	1	1	1	1	1	0	1	1	1	X	4

0 : "L" Level    1 : "H" Level

Fig. 27

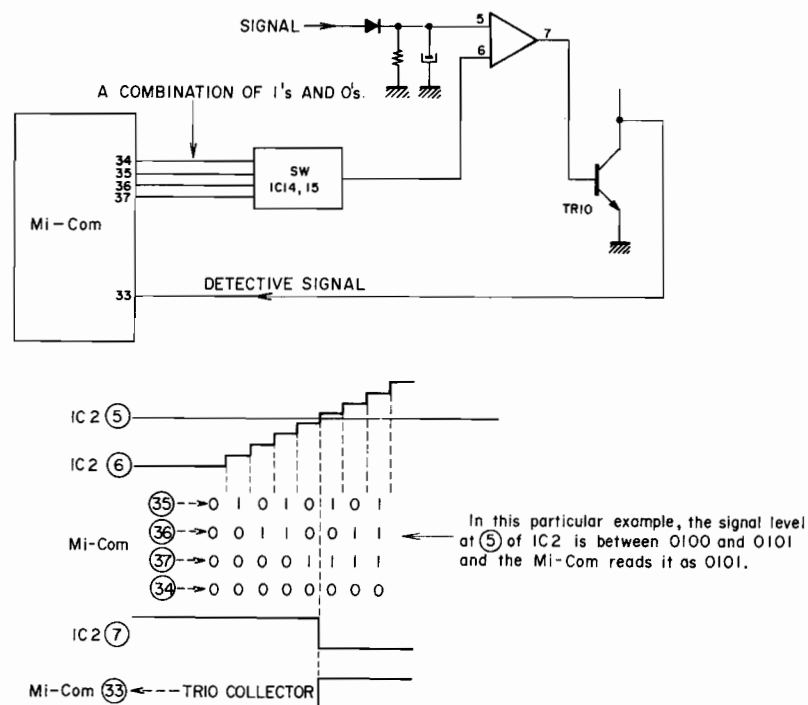

Fig. 28 Detecting and Reading Signal Levels

#### 4) Detecting and Reading Signal Levels

As seen above, terminal ⑥ of IC2 is supplied with the reference step voltage and terminal ⑤ with a DC voltage produced through rectification of the reproduced signal.

The reference voltage appearing at terminal ⑥ varies step-wise and thus exceeds the voltage at terminal ⑤ at a certain point, at which time the output at terminal ⑦ changes from "1" to "0". With the terminal ⑦ output changed from "1" to "0", the phase of TR10 is reversed, thereby

notifying terminal ③③ of the microcomputer that the signal has changed from "0" to "1". The microcomputer can tell the control signal (output at terminals ③④ - ③⑦) involved when the signal changed from "0" to "1", and remembers the bit combination of that control signal as a signal level detected. Thus, if the bit combination of the signal from terminals ③④ - ③⑦ is 0101, then 0101 is remembered as the value detected. What has been discussed above is illustrated in Fig. 28.

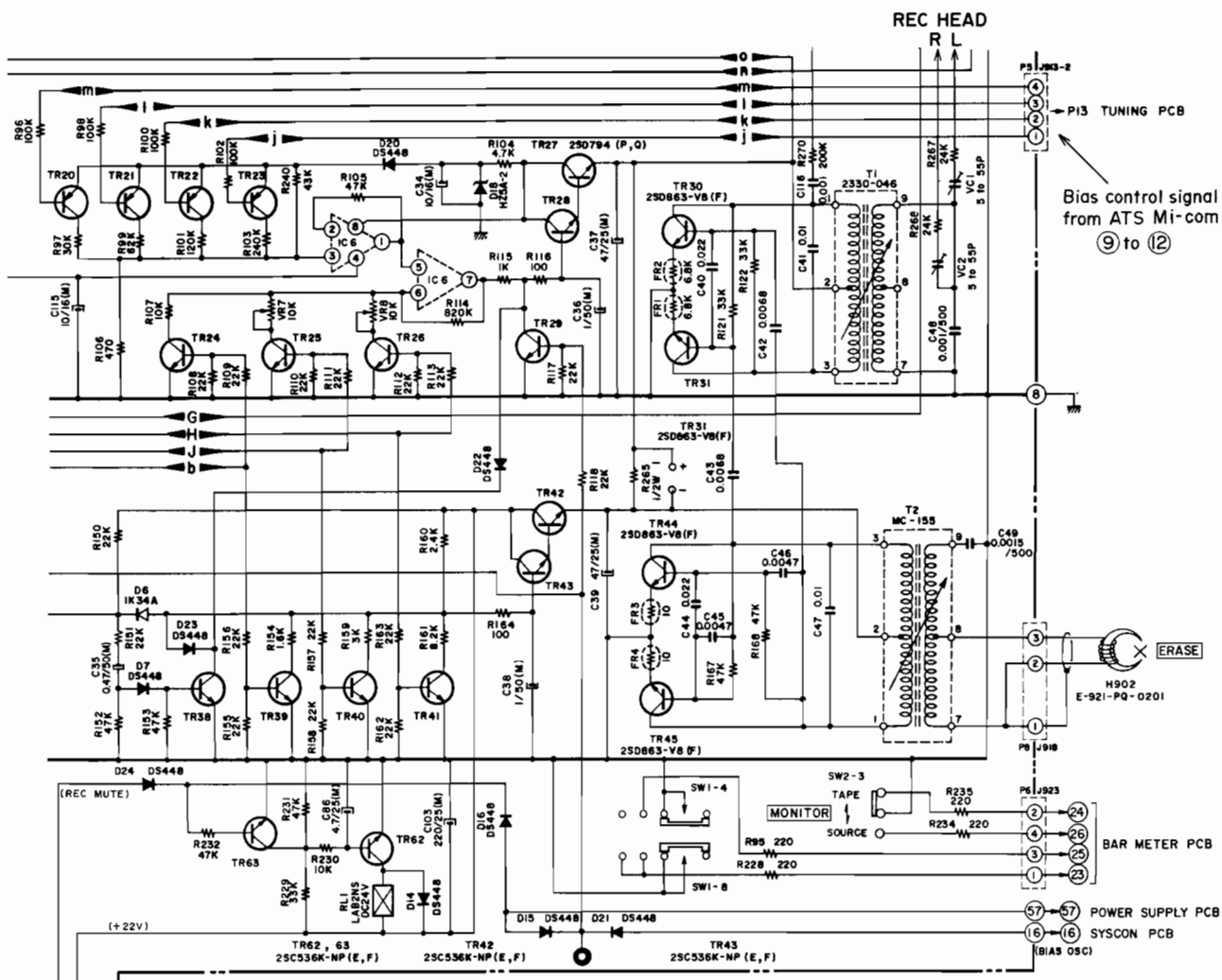

Fig. 29

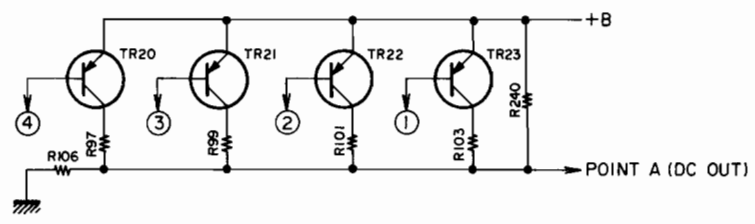
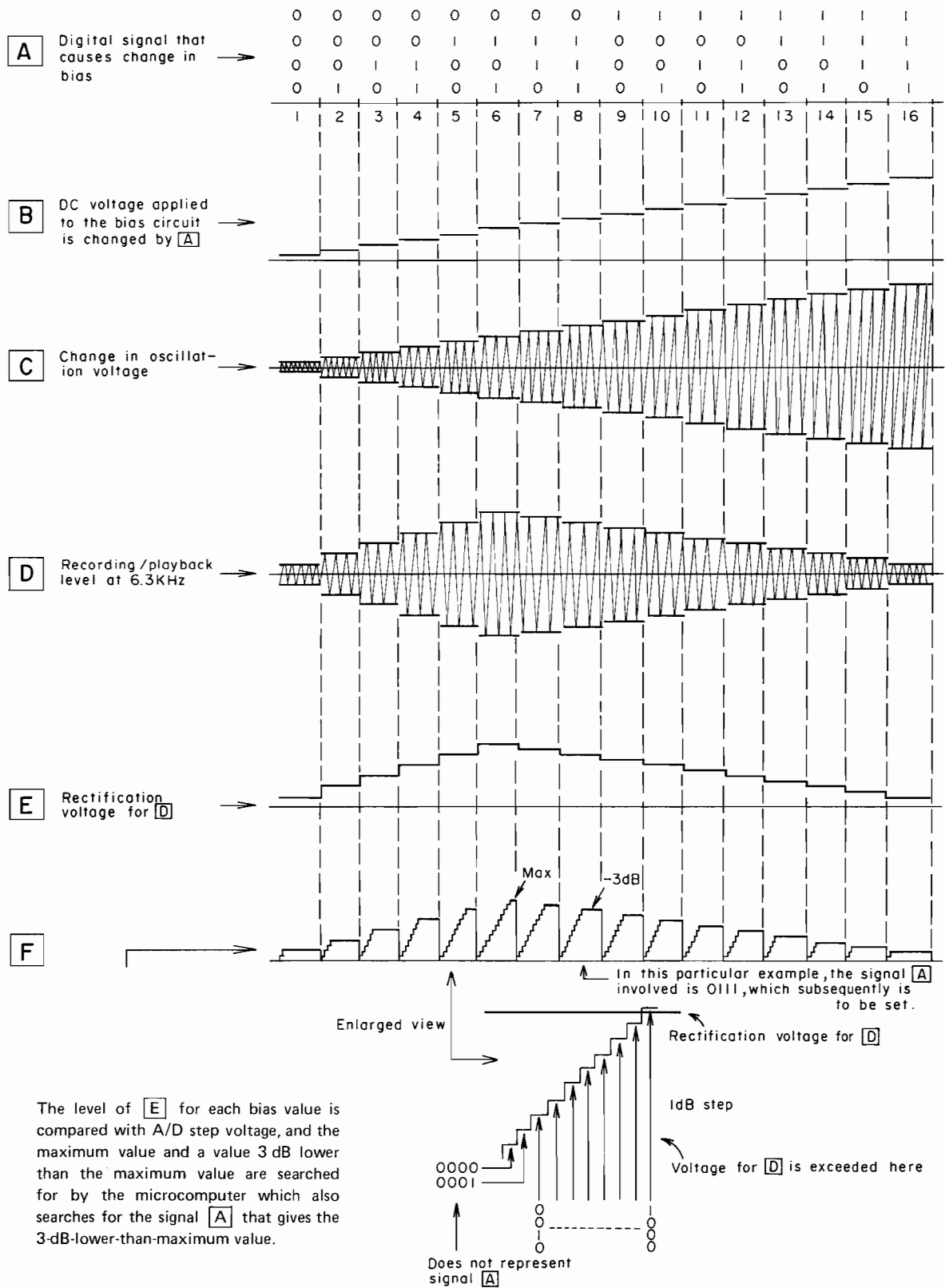

Fig. 30

**5-5. Bias Setting**

A signal of 6.3 kHz is recorded and reproduced at the same time and then the playback level is checked by varying the amount of bias in 16 steps (from low to high). As this is done, the microcomputer recognizes the maximum output level and holds, or remembers,

as a bias setting the step value which is over-biased by 3 dB (or 4 dB with metal and CrO<sub>2</sub> (SA)) from the step level involved. This bias values is used for subsequent Rec EQ and Rec level setting. The R-channel is used in the bias adjustment, which is repeated twice to take an average of the two step values obtained.



The level of **E** for each bias value is compared with A/D step voltage, and the maximum value and a value 3 dB lower than the maximum value are searched for by the microcomputer which also searches for the signal **A** that gives the 3-dB-lower-than-maximum value.

Fig. 31

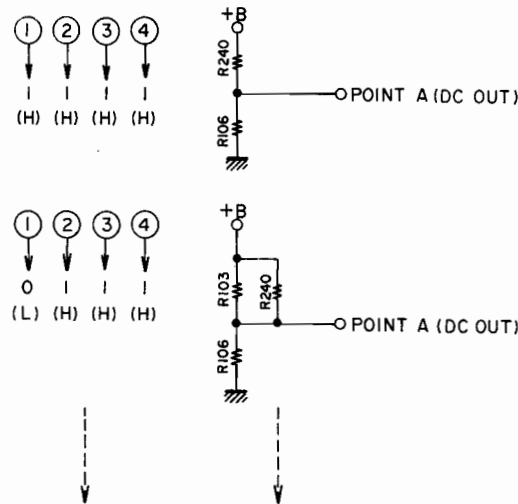

Fig. 32

If an error occurs, the adjustment is repeated. If the retry causes an error, then the adjustment is repeated once again (the fourth adjustment attempt). If the fourth attempt is still unsuccessful, the error is displayed externally and the operation stops after rewinding of the tape. Note that the use of the R-channel in bias adjustment helps to reduce ill effects caused mechanically by tape running.

The bias oscillation voltage can be varied as follows: In Fig. 30, the DC voltage at point A is varied by means of control signals ①, ②, ③ and ④.

As illustrated above, it is possible to vary the DC voltage at point A in 16 steps by causing inputs ① through ④ to be either 1s(H) or 0s(L).

This DC voltage at point A control TR27 and TR28 via the DC amp (IC6) to change the bias OSC DC supply voltage, and thereby vary the amplitude of oscillation voltage. In other words, the bias OSC output is varied by changing 1-0 (or H-L) combinations of outputs at terminals 9 - 12 of the microcomputer for ATS. Fig. 31 illustrates the steps involved in setting the bias.

#### 5-6. Rec EQ (L-ch, R-ch)/Rec Level (L-ch, R-ch) Register Selection

The microcomputer for ATS is programmed so that the Rec EQ/Rec level setting is attempted twice for each of L-ch and R-ch. Switching between Rec EQ and Rec level and between L-ch and R-ch is effected by way of terminals ②, ⑳ and ㉑ ( $R_0$ ,  $R_6$  and  $R_7$ ) of the microcomputer.

Fig. 33 shows the equivalent circuit and truth table of the IC TC4520BP. As can be seen from Fig. 33, when the enable terminal is at "1(H)" level, "Up Count" is effected by the clock pulse: when the reset terminal is at "1(H)" level,  $Q_1$  through  $Q_4$  are set to "0(L)" level.

Fig. 34 shows register selection signals from the microcomputer.

The signals are used to control the enable terminal of each binary up-counter (IC5 of IC6) so as to permit selection of L-ch Rec EQ, R-ch Rec EQ, L-ch Rec level or R-ch Rec level.

The enable terminal provides control to retain each register setting. For example, once the REC EQ (R-ch) setting has been made, the operation proceeds to the REC level (L-ch), at which time the enable terminal of the binary up-counter that controls REC EQ (R-ch) goes to "0(L)" level, thereby holding the value appearing at  $Q_0$  through  $Q_3$ .

Since switching to either one of the four registers (the ones for Rec EQ and Rec level setting) is done by way of the enable terminal, if one of the registers has its value being set, the remaining registers will have their settings in "held" state. Upon completion of the ATS operation, the enable terminal of each register goes to "0(L)" level, causing the set Rec EQ and Rec level to be held as they are.

L-ch/R-ch selection is made with a NAND gate (IC4) and the signal is applied to terminal ⑪ of IC16 to switch over the signal from the PB amp for delivery to the A/D converter. (See Fig. 35)

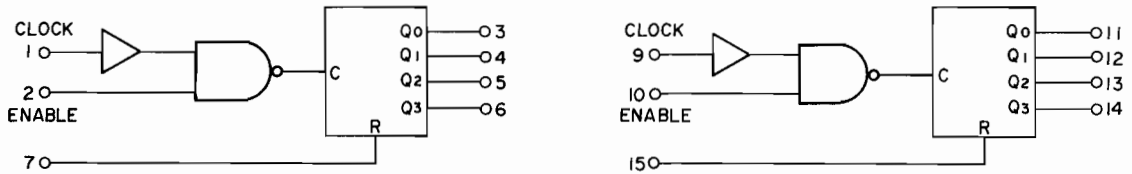
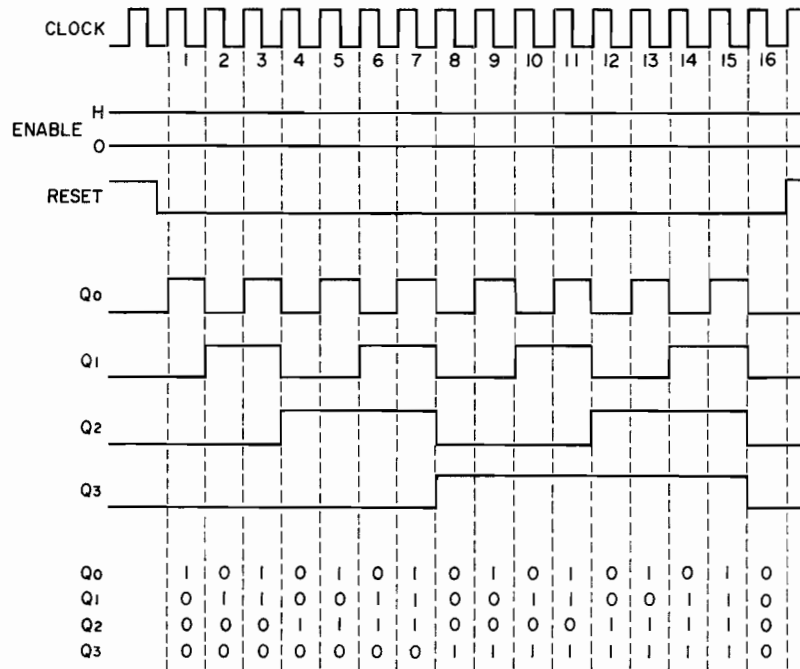

CLOCK	ENABLE	RESET	ACTION
	1	0	INCREMENT COUNTER
0		0	INCREMENT COUNTER
	X	0	NO CHANGE
X		0	NO CHANGE
	0	0	NO CHANGE
1		0	NO CHANGE
X	X	1	Q0 THRU Q3 = 0

X = Don't care.

Fig. 33 TC4520BP

RESISTER	PORT	R0	R6	R7
EQUALIZER(Lch)		0	1	0
EQUALIZER(Rch)		0	0	1
LEVEL(Lch)		1	0	0
LEVEL(Rch)		0	0	0

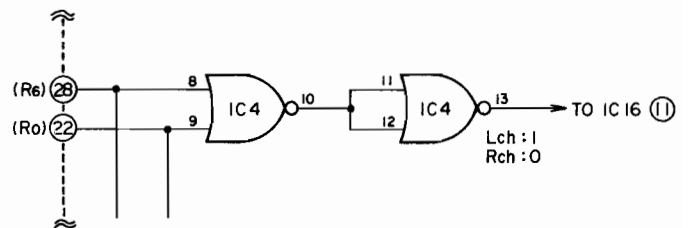

Fig. 34

Fig. 35



5-7. Rec EQ Setting

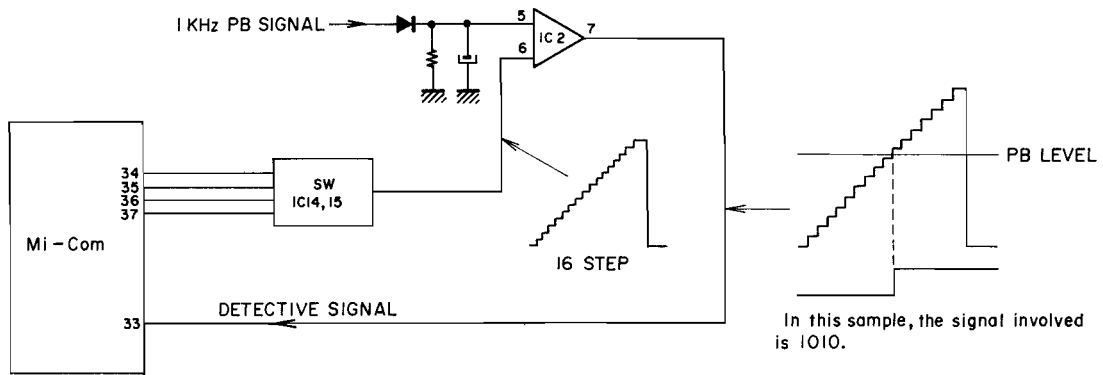

Fig. 36

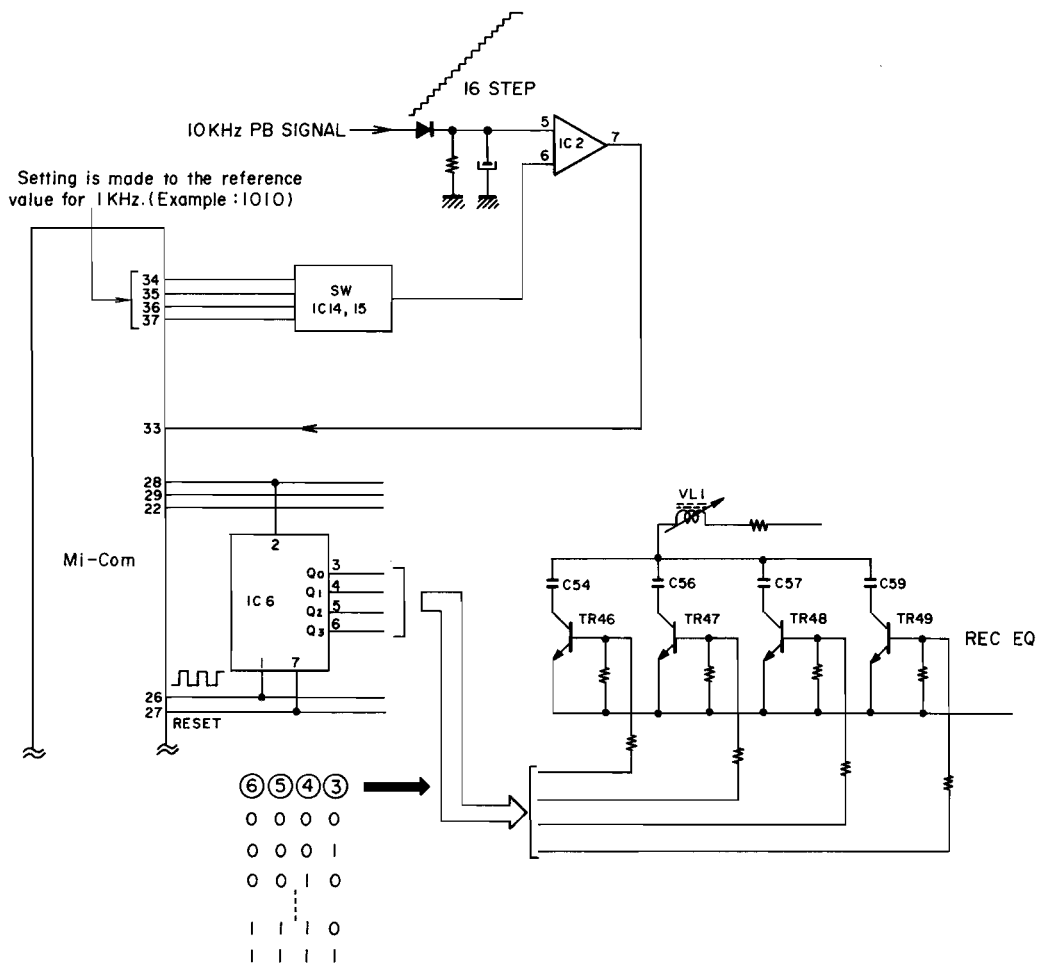

Fig. 37

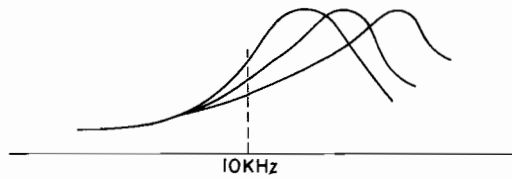

Fig. 38 Change in Rec EQ.

In Rec EQ setting, the Rec EQ is made to vary to match the record/playback level at 10 kHz with that at 10 kHz with that at 1 kHz so that a flat frequency characteristic can be obtained for recording/playback. Since no appropriate Rec level is not determined yet, a signal of 1 kHz (about -20 VU) is recorded and reproduced and the playback level is memorized. This is followed by the recording/playback of a 10 kHz signal.

At this point, the Rec EQ's variable circuit (pre amp's TR46 - TR49) is switched in 16 steps with the use of the binary up-counter (IC5 or IC6).

Of the A/D conversion step values for the 10 kHz PB level, the EQ value that gives the step value whose level is the same as that obtained with 1 kHz is memorized as a value to be set.

As shown in Fig. 37, a 1 kHz playback signal is supplied to the A/D converter circuit, at which time terminal ⑥ of IC2 is supplied with voltages in 16 steps by the use of 4-bit signals from terminals ③④ - ③⑦ of the microcomputer. The 4-bit signal appearing at terminals ③④ through ③⑦ when the step level has become equal to the 1 kHz playback level

is memorized as the detection level for 1 kHz, and the voltage applied to terminal ⑥ of IC2 at that time is taken as the reference voltage for 1 kHz.

The serial data (clock pulse) from terminal ②⑥ of the microcomputer is used to vary the 4-bit signal that appears at Q<sub>0</sub> - Q<sub>3</sub> of IC5 or IC6. (At this time, a 10 kHz recording signal is supplied.)

As the 4-bit signal (0000 through 1111) from IC5 or IC6 varies, TRs 46 through 49 of the Rec EQ are turned on/off to change the value of "C" connected to VL1 so as to alter the resonance frequency with VL1.

Since the C and VL1 are in the Rec amp's NFB circuit made up of TRs 32 through 36, the amount of NFB is changed by the frequency. (See Fig. 37.)

All this results in the frequency characteristic of the signal being changed as shown in Fig. 38.

In this manner, the 10 kHz PB level is changed in 16 steps through change in Rec EQ and the Serial data appearing at terminal ②⑥ of the microcomputer when the step level has become equal to the reference voltage for 1 kHz is memorized for Rec EQ setting.

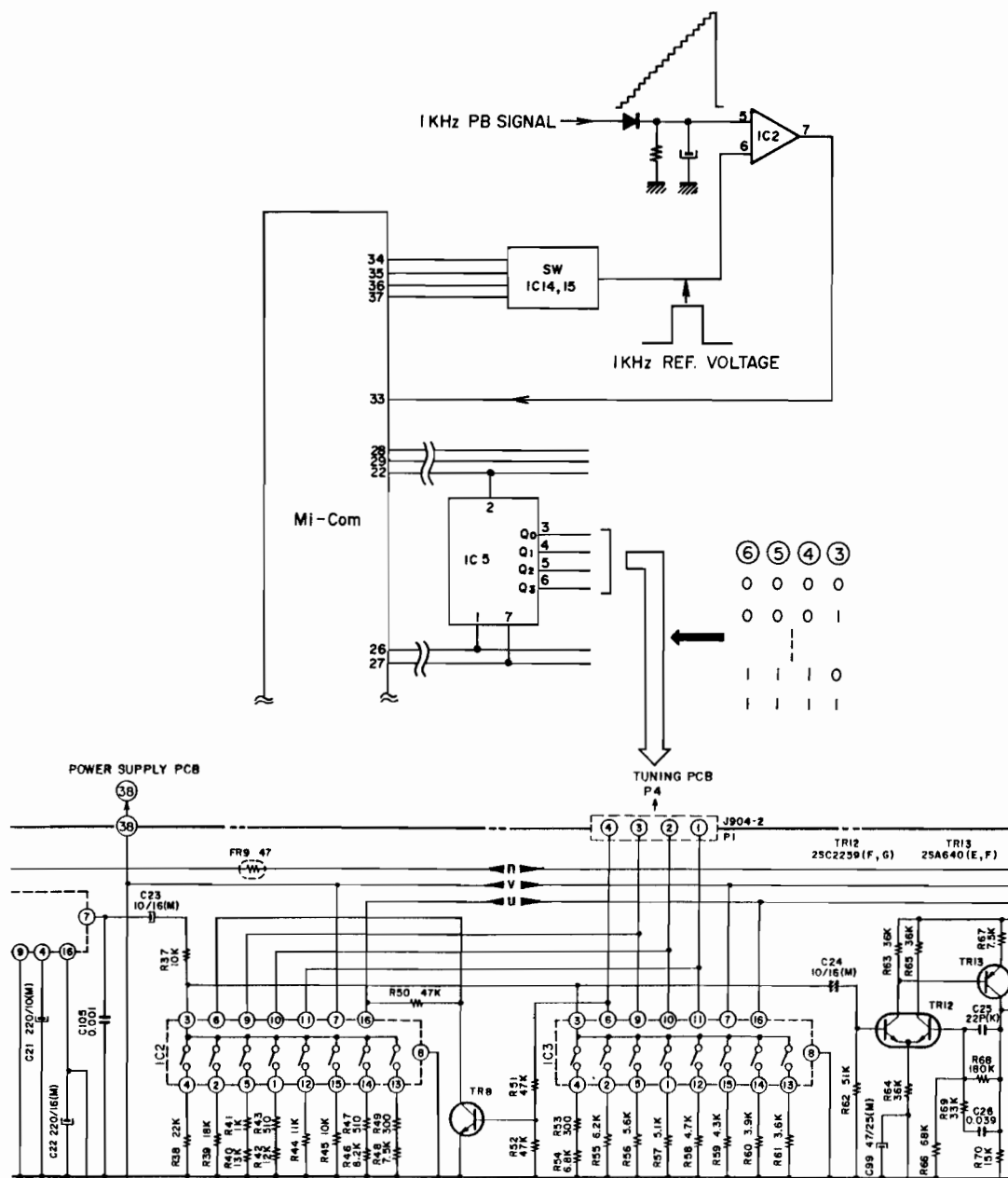

Fig. 39 Rec Level Setting

### 5-8. Rec Level Setting

In Rec level setting, the 1 kHz reference voltage supplied to terminal ⑥ of IC2 is compared with the 1 kHz PB level, and the serial data (clock pulse) appearing at terminal ②⑥ of the microcomputer when the PB level has become equal to the reference voltage is memorized as a value to be set.

The steps involved in the Rec level setting are as follows:

First, a programmed 4-bit signal appears at terminals ③④ through ③⑦ of the microcomputer and the 1 kHz

reference voltage is applied to terminal ⑥ of IC2. Then, a 1 kHz signal is recorded and reproduced and the PB level is applied to terminal ⑤ of IC2, at which time the binary up-counter is operated, as in the case of Rec EQ setting, by the serial data from terminal ②⑥ of the microcomputer to change the Rec level in 16 steps with IC2/IC3 of the Rec amp. Finally, the serial data appearing when the reference voltage has become equal to the PB level is memorized as a value to be set as the Rec level.

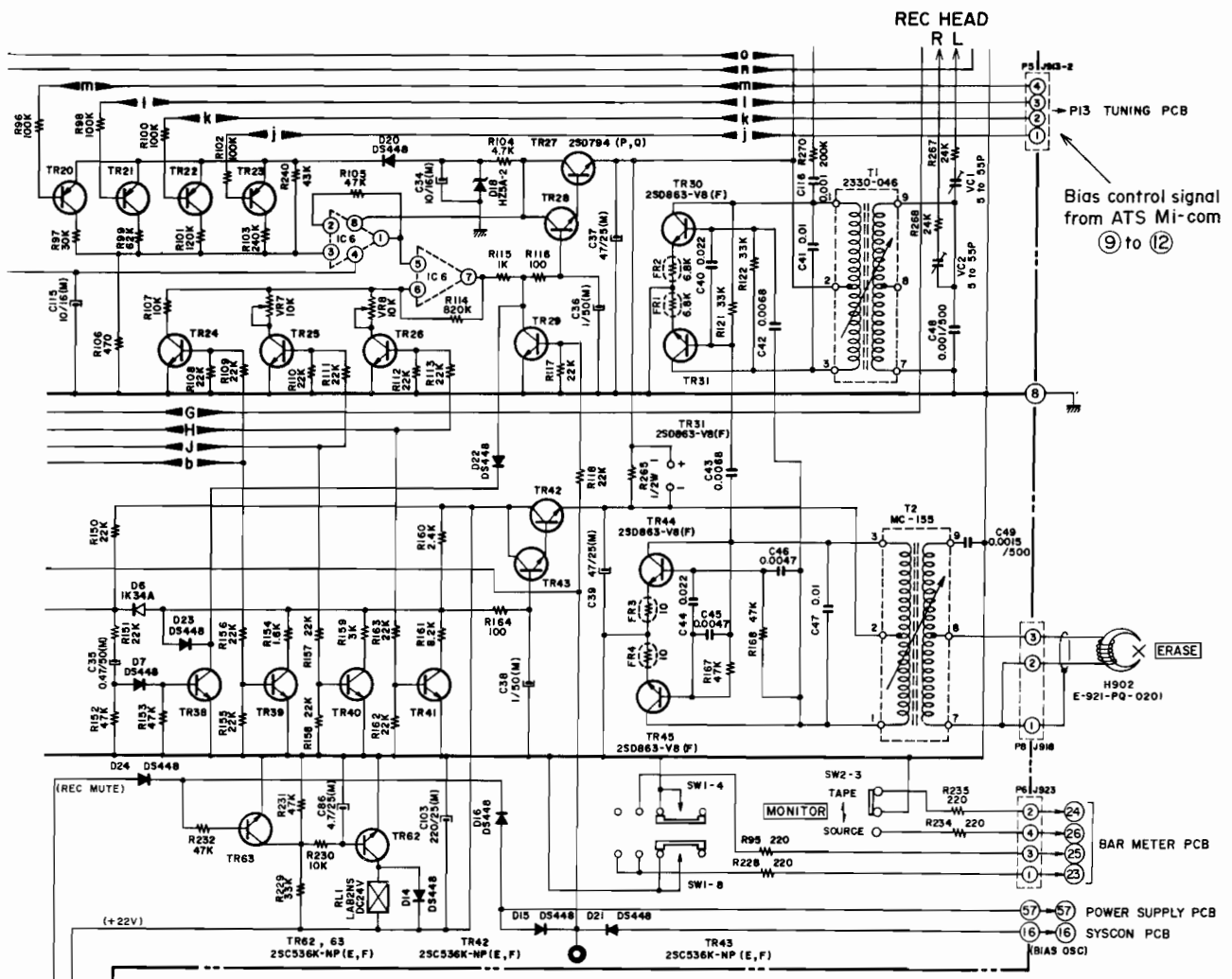

Fig. 40 Bias Oscillation Circuit

## 5-9. Bias Oscillation Circuit and Associated Circuits

### 1) Bias Oscillation Circuit

The original bias OSC circuit is one made up of TR44, TR45 and T2.

The oscillation frequency is determined by C47, T2.

The main bias OSC circuit is one that consists of TR30, TR31 and T1.

The main OSC is driven by the original OSC via C42 and C43, and oscillates at the same frequency.

This two-stage configuration is required to permit the bias voltage to be varied greatly: with one-stage construction, stabilized oscillation cannot be ensured.

### 2) TRs 66 – 68 and associated circuits

This circuit is incorporated to ensure safety. With the oscillation circuit not oscillating for some reason or other, a large current flows through the oscillation circuit. This circuit provides a means of lowering the voltage to be applied to the oscillation circuit when it is not oscillating.

With the oscillation circuit oscillating properly,

AC voltage is directed to the rectification circuit (D27) through C116 and R270 and turns on TR66. On the other hand, DC voltage is supplied to the base of TR67 via D26 and R273 from the emitter of TR27 (main OSC's DC voltage).

TR67 and TR68 make up a schmidt trigger circuit. If TR67's base voltage is higher than a certain voltage, TR67 is turned on and TR68 turned off, whereas if TR67's base voltage is lower than a certain value, TR67 is turned off and TR68 turned on.

A thyristor gate is connected to the collector of TR68 via R280, R281 and C119. When voltage is applied to the thyristor gate, the thyristor is turned on. With the OSC circuit oscillating properly, TR66 is turned on and thus the voltage applied to the base of TR66 is lowered with TR67 being OFF and TR68 being ON. For this reason, no voltage is applied to the thyristor gate, which results in the thyristor being OFF.

When the bias OSC circuit stops functioning, TR66 is turned off, which in turns the thyristor on, thereby lowering the voltage to be supplied to the bias OSC circuit.

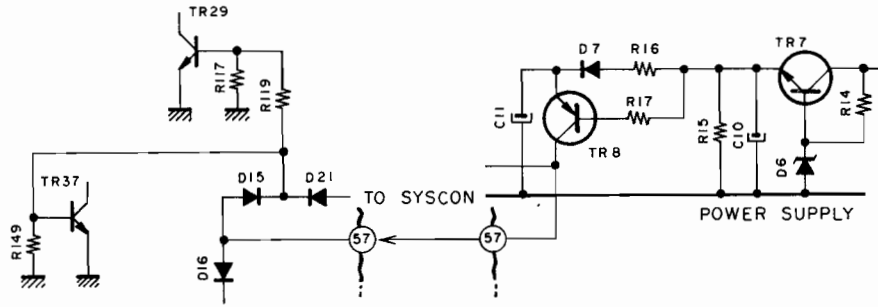

Fig. 41

### 3) Function of TR29 and TR37

The circuit shown in Fig. 41 provides control over activating/deactivating the bias OSC circuit. In other than the Rec mode, "H" is applied to the bases of TR29 and TR37 from the system control via D21 to deactivate the bias OSC. In the Rec mode, the base potential is caused to be at "L" level to turn off TR29 and TR37, thereby activating the bias OSC.

TR38 delays the start of oscillation through C35 and R51 to prevent the bias OSC from being activated as soon as the Rec mode is established. (This feature helps to reduce click noise.)

As can be seen from Fig. 41, the bases of TR29 and TR37 are connected to the power supply circuit via D15. TR8 is normally off because no base bias is applied to it, with both C11 and C10 being charged.

If the power supply is turned off while the bias

OSC circuit is oscillating, C10 discharges immediately but C11 can not. The base of TR8 is grounded by R17 and R15 and its emitter is forward biased because of the charged large-capacity condenser connected to it, causing the electric charge in C11 to be delivered to terminal 57 through TR8.

Immediately after the power is turned off, bias oscillation is stopped, and RL1 is actuated at the same time to stop the signal to the Rec head.

## 6. EXPLANATION OF SYSCON CIRCUIT ACTION

The syscon circuit also incorporates a microcomputer which provides function mode switching, control of the reel motor, plunger, etc. TIME/TAPE counter display and so forth. Fig. 42 shows terminal connections on the microcomputer (MB8841M-373M).

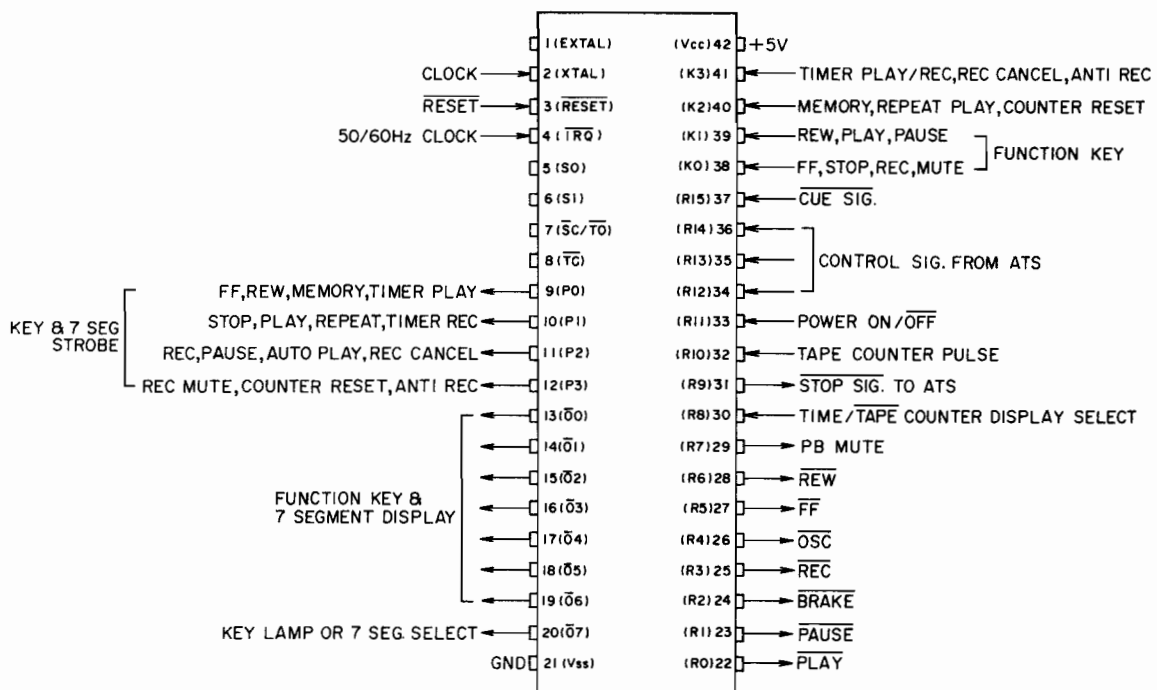

Fig. 42 Terminal Connections on the Microcomputer for Syscon

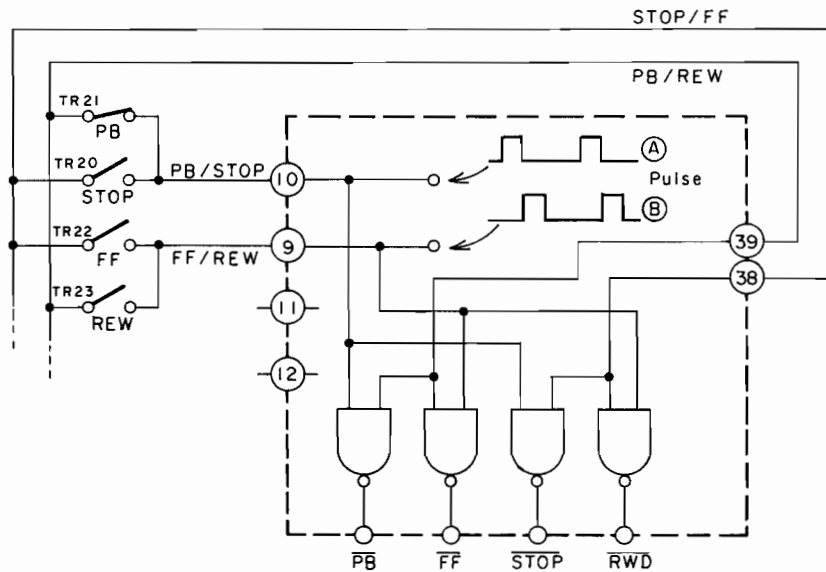

Fig. 43 Operating Principle of Function Mode Selector

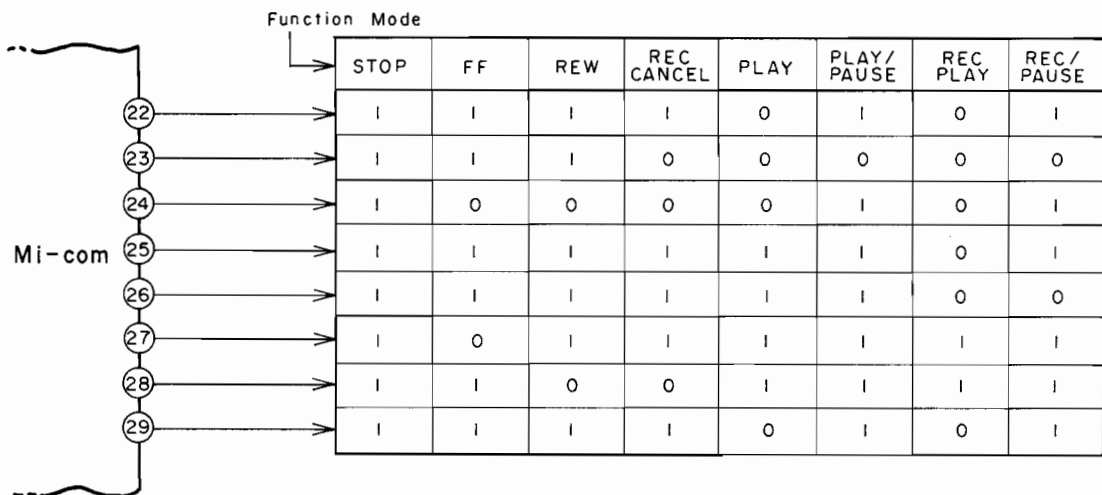

Fig. 44

### 6-1. Function Mode Selector Circuit

The timing of pulses from the microcomputer is used to provide control over selection of each function mode. In the accompanying diagram, only four modes (PLAY, FF, REW and STOP) are shown for simplicity.

Pulses of different timing always appear at terminals ⑨ - ⑫ of the microcomputer. When the PLAY key is depressed, the PB switch (TR21) is closed, permitting the pulse ① from terminal ⑩ to be routed to terminal ⑳ and then to a NAND gate within the microcomputer.

The NAND gates are always supplied with pulses ① and ② internally, and thus a pulse appears at the output of the NAND gate which matches in timing with the pulse ① from terminal ⑳. This pulse is used to determine which of the function mode keys was depressed, and control the plunger drive, reel motor drive, etc. connected to output terminals R<sub>0</sub>-R<sub>7</sub> of the microcomputer so as to establish the appropriate function mode.

Fig. 44 illustrates the state of the microcomputer in each function mode.

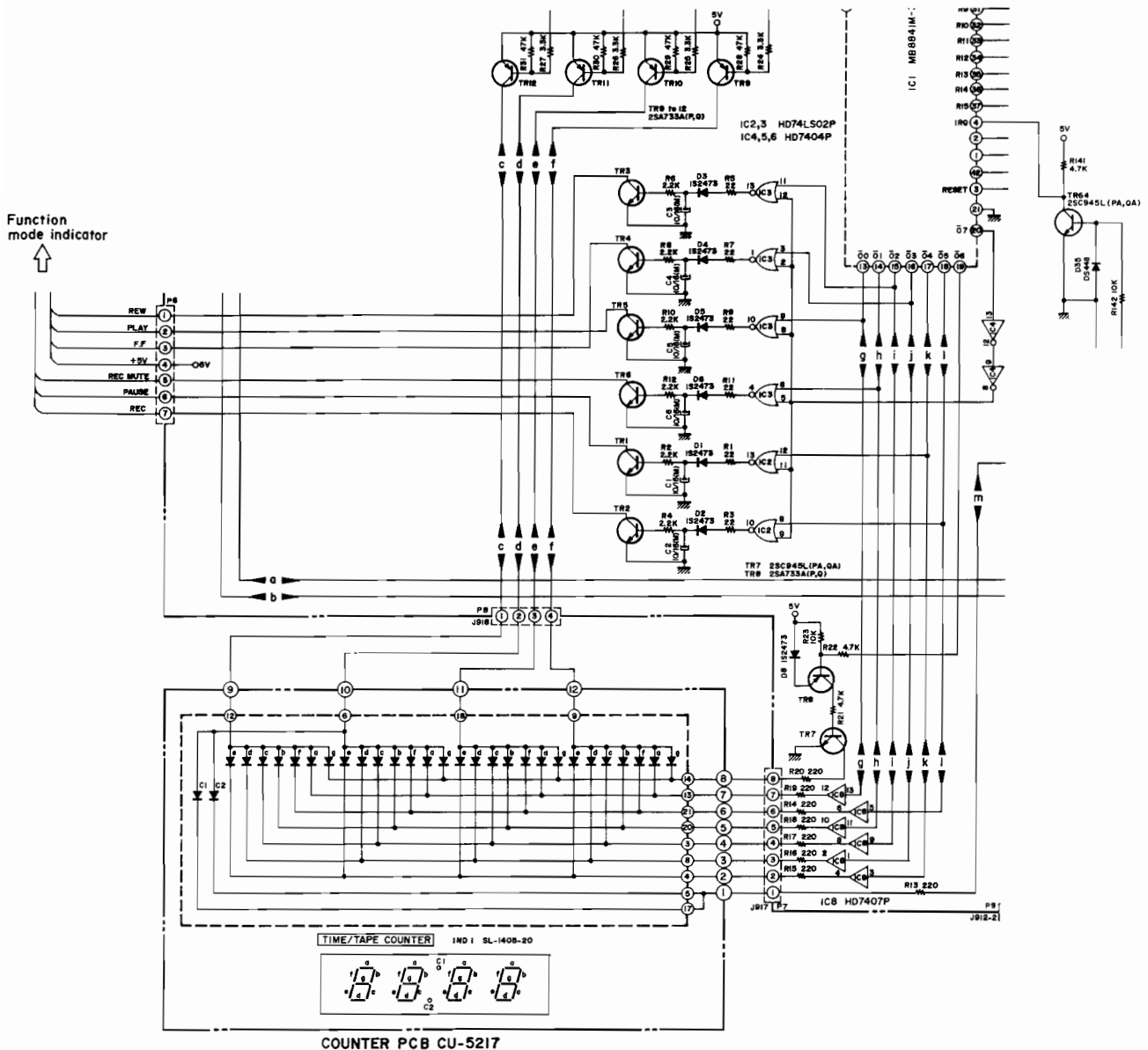

Fig. 45 Function mode Indicator Activation and Counter Display Circuits

## 6-2. Function Mode Indicator Activation Circuit and Counter Display Circuit

### 1) Function Mode Indicator Activation Circuit

The timing of control signals from the micro-computer is also used to cause the indicator for each function mode to come on.

Given here is an explanation of the PLAY/PAUSE mode illustrated as an example in Fig. 46. In the PLAY/PAUSE mode, the function mode indicator PAUSE stays "on", while the PLAY indicator blinks. The "Function Mode Ind." column (from  $O_0$  through  $O_5$ ) in Fig. 46 indicates that PAUSE IND is at "L" level, PLAY IND at "L/H" (blink) and the other INDs all at "H" level.

The signal ( $O_0$  through  $O_5$ ) plus the signal  $O_7$  are

supplied to NOR gates shown in Fig. 45. Shown above as an example is the PAUSE indicator activation circuit. Since both  $O_4$  and  $O_7$  are at "L" level (see the "Function Mode Ind." column), a waveform shown at ③ appears at terminal ⑬ of IC2.

The waveform is then rectified to turn TR1 on, thereby causing the PAUSE indicator to come on. Similarly, the PLAY indicator comes on and blinks only when the  $O_0$  signal coincides with the signal  $O_7$  at "L" level.

As discussed above, each mode indicator is activated by supplying the  $O_7$  and  $O_0$ - $O_5$  outputs from the microcomputer to the appropriate NOR gate and then turning TR1 - 6 on according to the operation timing.

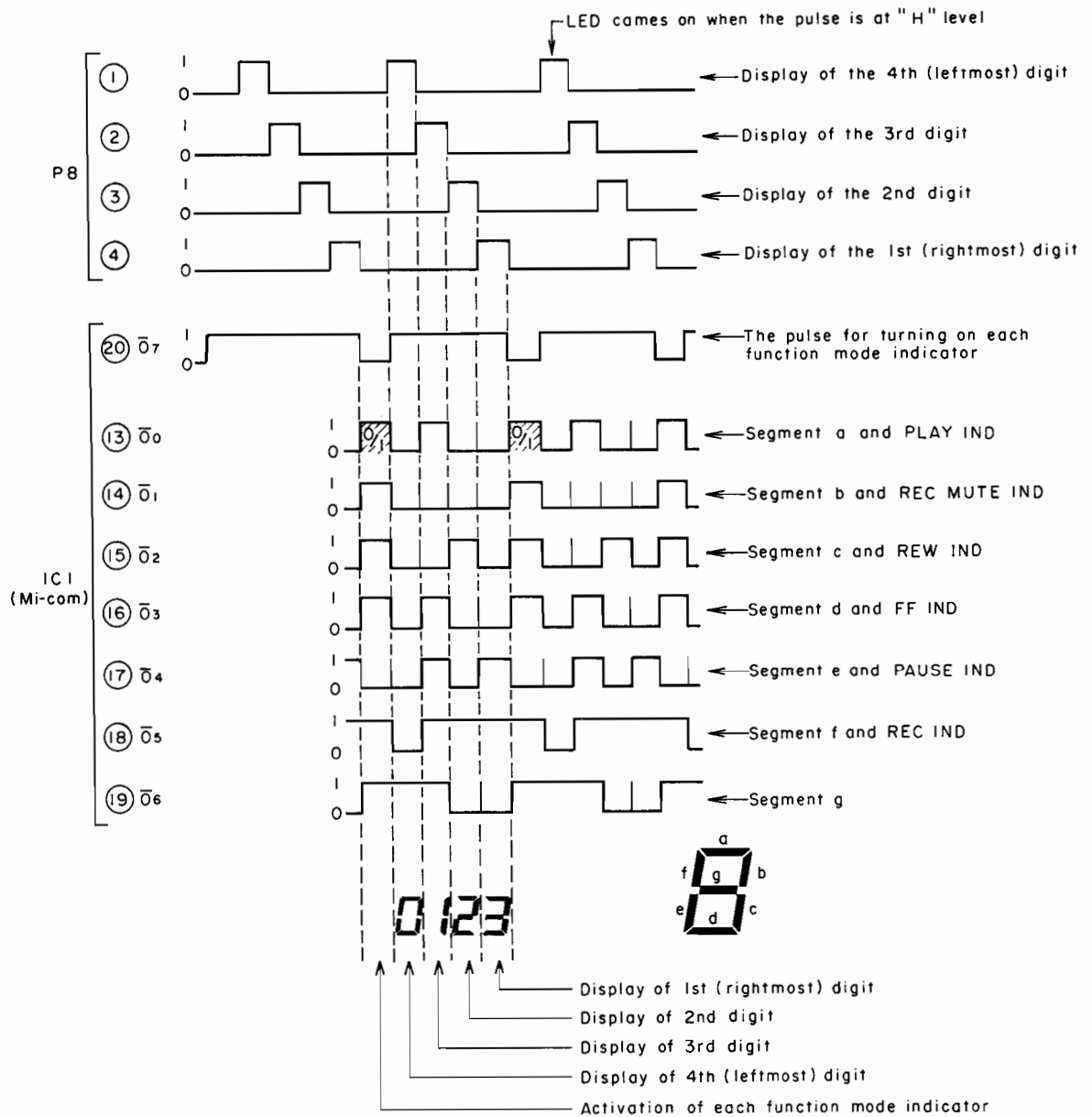

Fig. 46

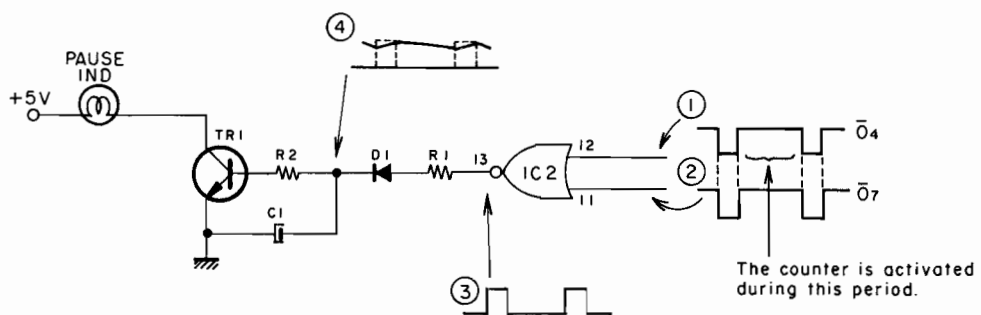

Fig. 47 PAUSE Indicator Activation Circuit



## 2) Counter Display Circuit

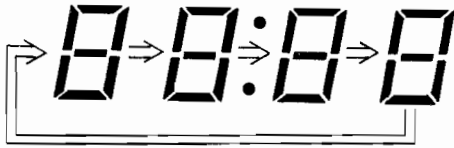

Fig. 48

Display of the counter is also controlled by pulses from the microcomputer. It should be noted here that each digit of the counter is not kept "on" at all times. If the counter is displayed by shifting each digit to be lighted in sequence as shown in Fig. 48, the digits still look as if they were kept "on" all the time thanks to the after-image effect of our eyes.

This is the principle on which a system known as the dynamic display system is based. Fig. 46 shows the timing chart of the dynamic display system. The waveforms appearing at ① through ④ of P8 are used to shift each LED digit to be lighted in sequence: for example, it can be seen from Fig. 46 that the rightmost digit comes on only when the waveform P8 ④ is at "H" level. The signal levels appearing at  $O_0 - O_6$  when the P8 ④ is at "H" determine which segments of the digit are to be turned on to display a specific number. Also, since segments of the LED display are of "anode common", each segment comes on when the signal level at  $O_0$  through  $O_6$  is "L".

As an example in Fig. 46, the rightmost digit has its segments a-d and g turned on and segments e and f turned off, resulting in the number 3 being displayed. The remaining digits also have their respective segments either turned on and off

according to the signal levels at  $O_0$  through  $O_6$ , all this results in the display of 0123 on the LED counter. When the counter is actually counting, the waveform appearing at  $O_0 - O_6$  is changing constantly.

The tape count pulse, or the pulse from the photocoupler on the detector PC Board whose waveform is reshaped by TR56, TR53 and TR54, is supplied to the microcomputer. The pulse is then counted within the microcomputer before being sent out through terminals  $O_0 - O_6$  as the display signal. Note that TR7 and TR8 shown in Fig. 45 (circuit diagram) are incorporated because of insufficient buffer capacity of IC8.

For time counting, 50 or 60 Hz from the commercial power source has its waveform reshaped by TR64 and then is supplied to the IRQ terminal of the microcomputer. The 50/60 Hz switching is automatically detected inside the microcomputer. This frequency is used to count time in seconds.

### 6-3. ATS $\longleftrightarrow$ Syscon Control Signal

With ATS, control signals are sent out, apart from the function keys, from the ATS circuit to the SYSCON circuit. In other words, signals are delivered to the microcomputer for SYSCON from the microcomputer for ATS so as to control the action of the system control illustrated in Fig. 49.

Fig. 50 gives the control signals in use.

In addition, a control signal is also sent out from the SYSCON's microcomputer to the ATS's microcomputer. That signal, called the STOP signal, is used to forcibly stop the ATS. The system is designed such that only the stop signal can be accepted during the auto tuning operation. To cancel the auto tuning mode, the STOP key must be depressed to cause the IRQ terminal of ATS's microcomputer to go to "L" level for forced termination. Fig. 51 shows the timing chart for the IRQ terminal.

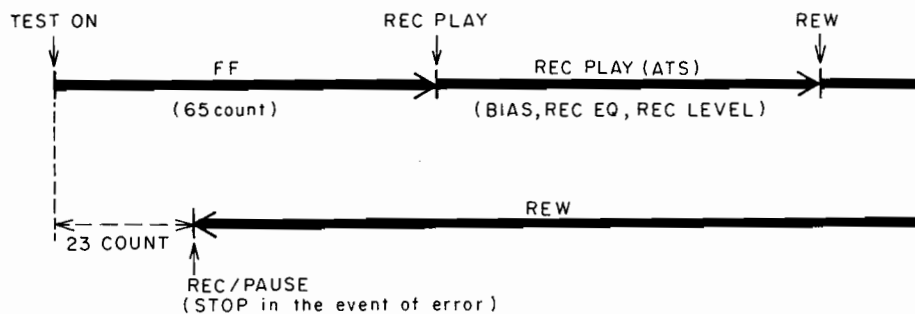
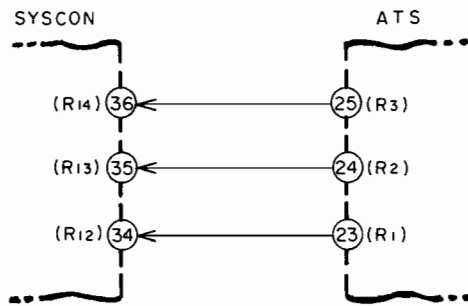

Fig. 49 Syscon Action with ATS



PORT (ATS) FUNC- TION MODE	R3	R2	R1
NO OPERATION	0	0	0
REW	0	0	1
FF	0	1	0
STOP	0	1	1
REC PLAY	1	0	0
REC / PAUSE	1	1	1

(1: H Level)  
(0: L Level)

Fig. 50 ATS → Syscon Control Signal

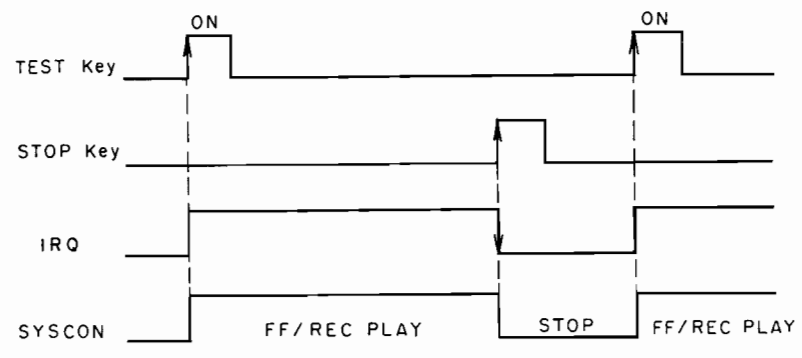

Fig. 51 Timing Chart for IRQ Terminal

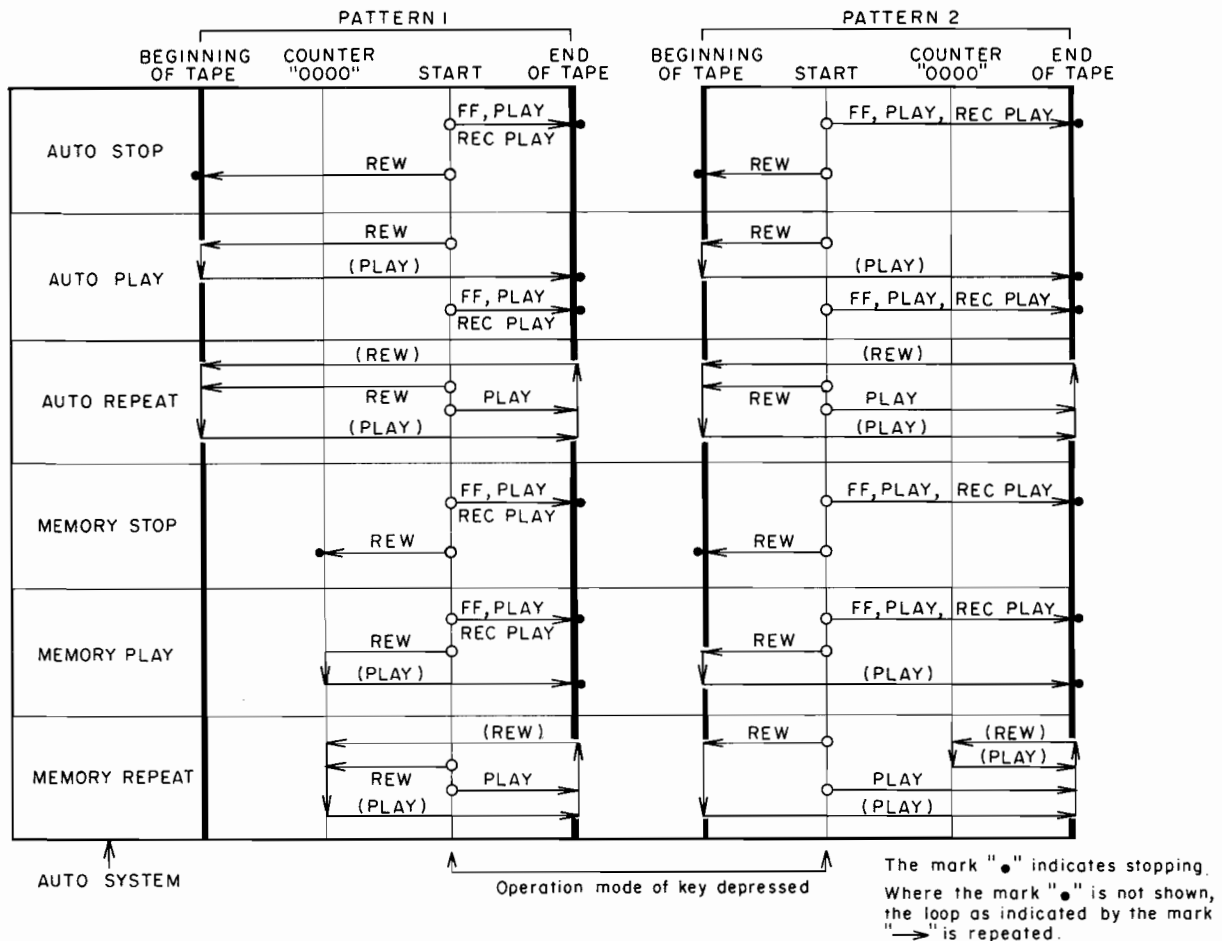

Fig. 52 Auto System Operation

#### 6-4. Auto System Operation

With the GX-F95, the auto system switch may be used with the counter memory to provide for the auto system operation illustrated in Fig. 52.

With pattern 1, a mode key is depressed between "0000" on the counter and the end of tape, whereas with pattern 2, a mode key is depressed between the beginning of tape and "0000" on the counter.

### 7. FACTORY REFERENCE TAPE

Where the ATS is not made use of, the tape deck is adjusted using the factory reference tape, just as with conventional models (e.g., GX-F90).

Types of reference tape in use are:

- Normal : Maxell UD C-60
- CrO<sub>2</sub> : TDK SA C-60
- Metal : TDK MA-C C-60

Note that with Fe-Cr tape, there is no guarantee that the optimum condition can be attained with the use of either ATS or reference tape.

With the deck in the "reference" state, the signals from the microcomputer that control the bias, Rec EQ and Rec level are predetermined for each of normal, CrO<sub>2</sub> and metal tapes (each tapes being identified by cassette pack configuration). In other words, fixed resistances and condensers are connected

in the ATS bias, ATS Rec EQ and ATS Rec level circuits. At the factory, the manual bias, Rec peaking (VL1) and manual Rec level are adjusted using the appropriate reference tape just as with conventional models such as GX-F90.

In addition, the height of the head, azimuth, etc. are also adjusted in the "reference" state.

### 8. SPECIAL COMMENTS

As mentioned in the foregoing discussion, ATS-based operations are performed with use of pulses and it is therefore necessary to use an oscilloscope in troubleshooting. Since there is no decisive method of determining if the microcomputer chip is functioning properly, waveforms appearing at various points must be checked when there is any indication of malfunction.

It is also necessary to check for +B or proper RESET action with power turned on (terminal ③ of the microcomputer goes to "L" momentarily).

If every retry with ATS fails and the error condition occurs again, check must also be made to see if the proper frequency characteristic or Rec level has been obtained with the deck placed in the "reference" state.

## VII. MECHANISM ADJUSTMENT

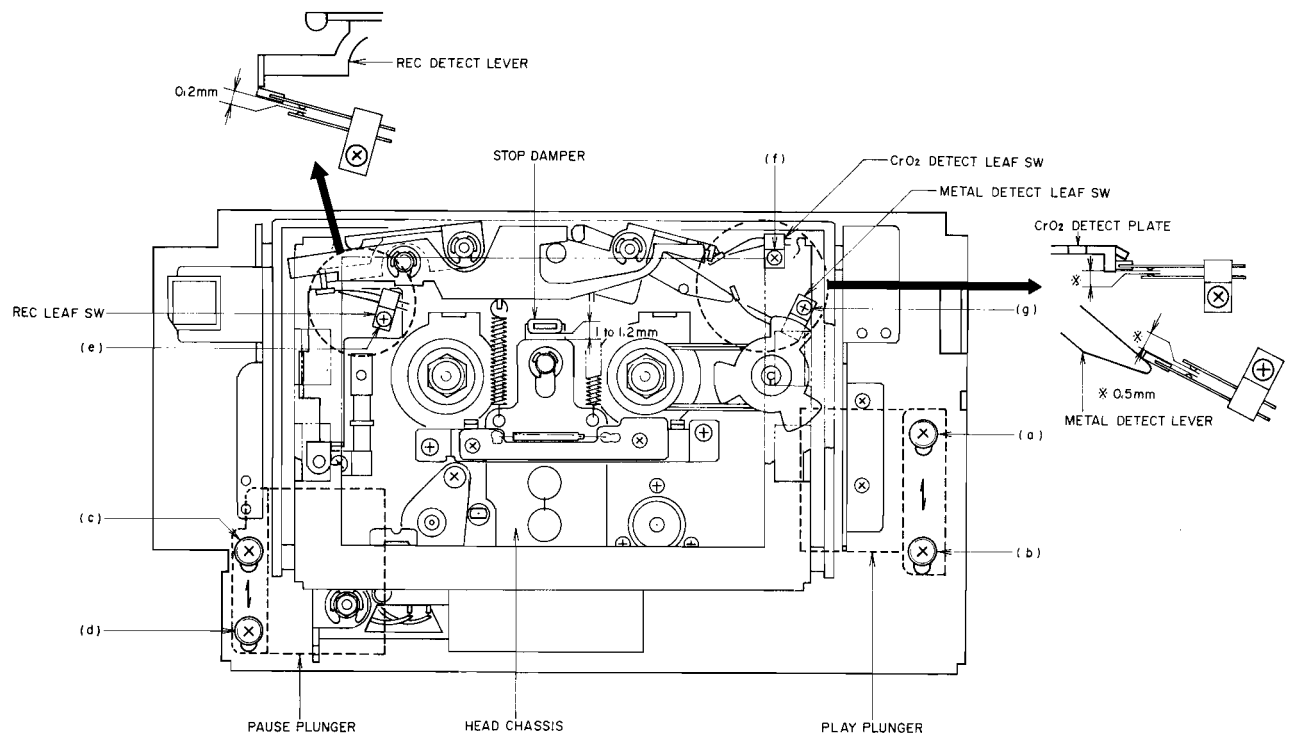

Fig. 53

### 1. PLAY PLUNGER INSTALLATION POSITION ADJUSTMENT (Refer to Fig. 53)

Put in PLAY mode to activate the PLAY plunger. Adjust the Position of the play plunger with the installation screws (a), (b) so that the distance between the top edge of the head chassis and the stop damper to 1.0 to 1.2 mm. After adjustment coat the installation screws with screw lock.

### 2. PAUSE PLUNGER INSTALLATION POSITION ADJUSTMENT (Refer to Fig. 53)

Insert a head projection gauge and confirm that in the PLAY mode the head projection is  $3.3 \pm 0.15$  mm. (If it does not meet the specifications, refer to VIII. HEAD ADJUSTMENT). Put into the PAUSE mode from the PLAY mode and adjust the PAUSE plunger's position with installation screws (c), (d) to give a head projection of  $2.4 \pm 0.1$  mm. After adjustment, coat the installation screws with screw lock and confirm that there is a distance of about 0.5 mm between the erase head and pad, and the pinch roller and capstan.

### 3. REC LEAF SWITCH INSTALLATION POSITION ADJUSTMENT (Refer to Fig. 53)

Loosen the installation screw (e) and adjust the position of the REC LEAF switch until the LEAF switch contact point gap is over 0.2 mm with the

EJECT button depressed, and there is sufficient LEAF switch contact point pressure with the cassette holder set. After adjustment, insert a cassette pack with the recording defeat tabs intact to confirm there is recording and then insert a cassette pack without the recording defeat tabs and confirm that it does not record.

### 4. CrO<sub>2</sub> TAPE DETECT LEAF SWITCH INSTALLATION POSITION ADJUSTMENT (Refer to Fig. 53)

Loosen the installation screw (f) and adjust the position of the CrO<sub>2</sub> TAPE DETECT LEAF switch until the LEAF switch contact point gap is over 0.5 mm with the EJECT button depressed, and there is sufficient LEAF switch contact point pressure with the cassette holder set.

### 5. METAL TAPE DETECT LEAF SWITCH INSTALLATION POSITION ADJUSTMENT (Refer to Fig. 53)

Loosen the installation screw (g) and adjust the position of the METAL TAPE DETECT LEAF switch until the LEAF switch contact point gap is over 0.5 mm with the EJECT button depressed, and there is sufficient LEAF switch contact point pressure with the cassette holder set.

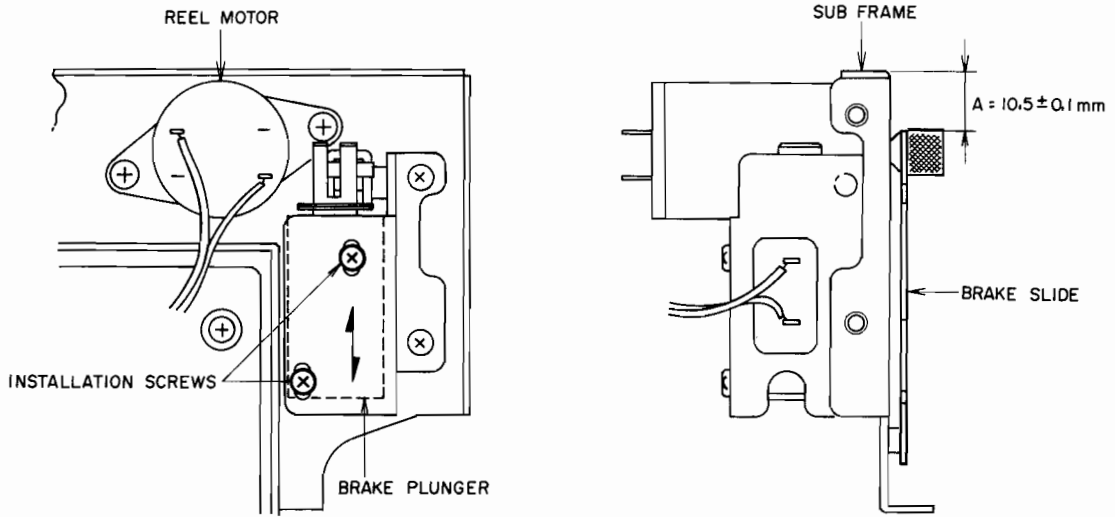

Fig. 54

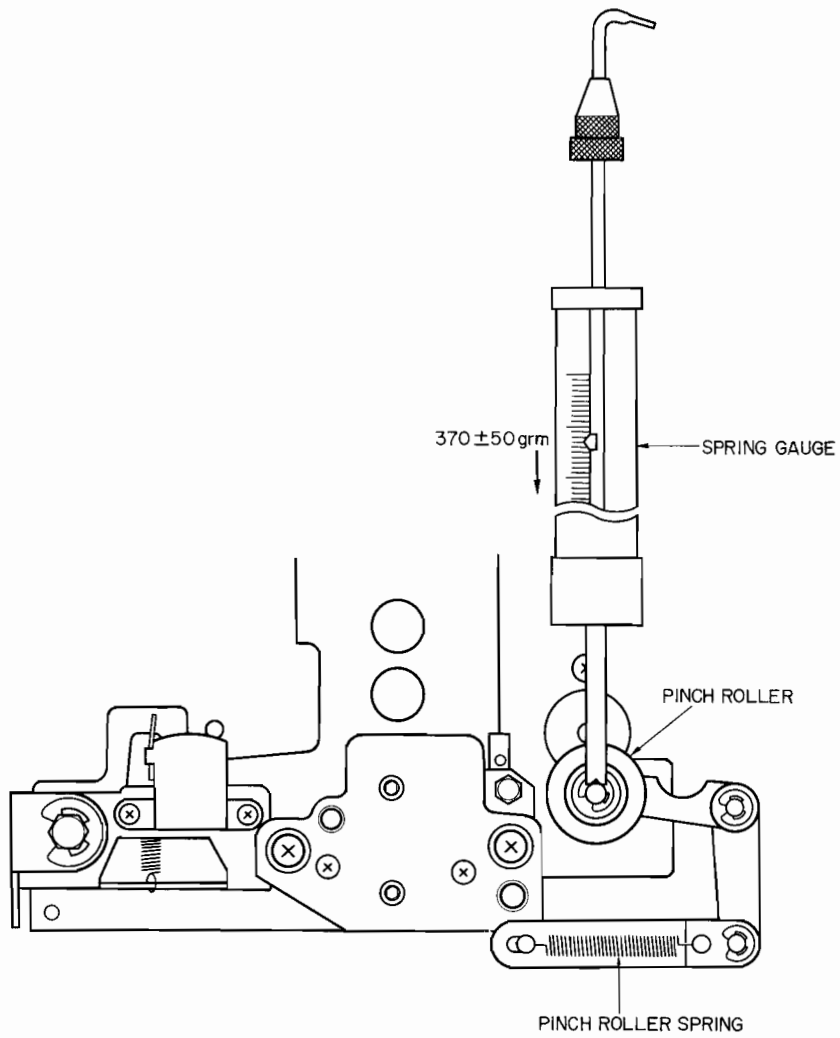

Fig. 55

---

## 6. VERIFICATION OF ACTION OF AUTO TAPE SELECTOR

Prepare a normal tape, CrO<sub>2</sub> tape and metal tape with a detection notch and verify that switching is automatically made to the appropriate mode for the specific tape set on the deck. Note that the tape selector switch must be set to AUTO.

If the selector malfunctions, then adjustments described in items 4 and 5 must be made once again.

## 7. BRAKE PLUNGER INSTALLATION POSITION ADJUSTMENT (Refer to Fig. 54)

With the brake off (for example during REW), adjust the brake plunger's position with the installation screws (a), (b) so that the distance between the tip of the brake slide and the sub frame is  $10.5 \pm 0.1$  mm.

## 8. PINCH ROLLER PRESSURE MEASUREMENT (Refer to Fig. 55)

Put in PLAY mode. Push pinch roller arm down with the spring gauge, push the pinch roller 1–2 mm from the capstan and release slowly.

Read the spring gauge at the moment the pinch roller touches the capstan and begins to rotate. Specified contact pressure measurement of  $380 \pm 50$  gm. If no measurement is obtained, replace the pinch roller spring.

## 9. WINDING TORQUE MEASUREMENT IN EACH MODE

Insert cassette torque meter and measure in each mode.

For fast forward and rewind measure at the end of the tape when the tape has stopped running.

The specified torque is:

- Playback : 30 to 50 g-cm.
- Fast Forward, Rewind : 70 to 120 g-cm.

# VIII. HEAD ADJUSTMENT

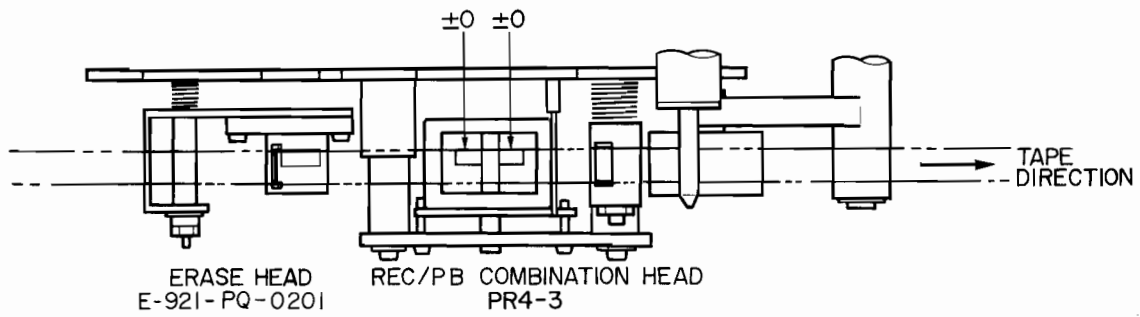
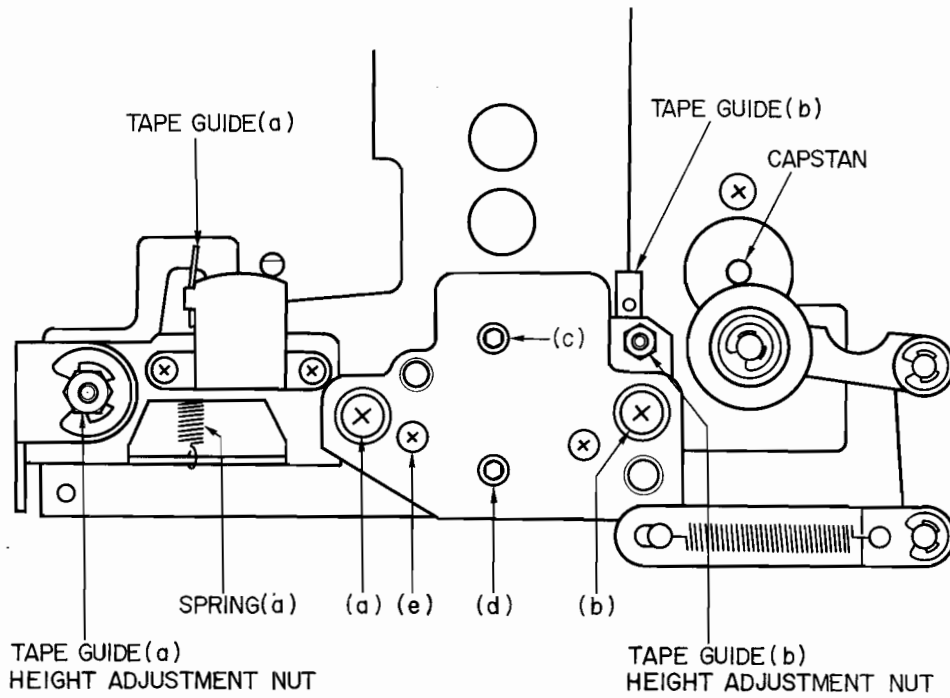

Fig. 56

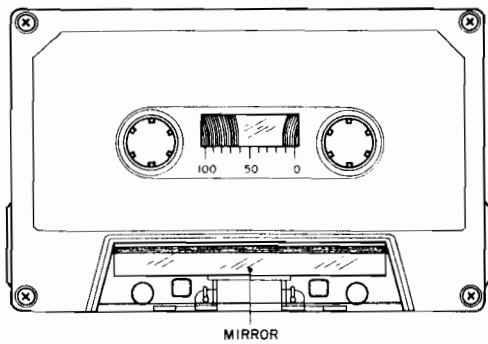

Fig. 57

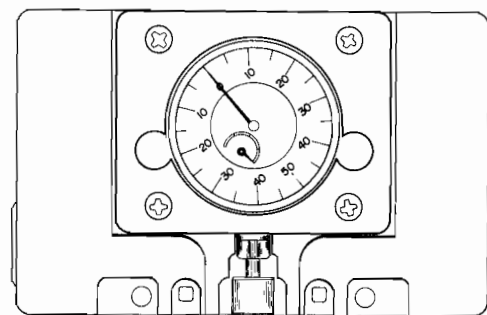

Fig. 58

---

## 1. TAPE GUIDE HEIGHT ADJUSTMENT

(Refer to Figs. 56, 57)

- 1) When using an ordinary cassette, the tape guides and heads, etc. are not visible. As shown in Fig. 57 use a cassette tape from which part of the cassette case has been cut out and a mirror installed for easy visibility of the head area when making tape guide height adjustment.
- 2) At playback mode, adjust tape guide (a) and tape guide (b) height with tape guide height adjustment nuts so that the tape runs smoothly and does not catch on the tape guides.

## 2. REC/PB COMBINATION HEAD PROJECTION ADJUSTMENT

(Refer to Figs. 56, 58)

Insert the AKAI Head Projection Gauge (Fig. 58) and adjust screws (a) and (b) so that it reads  $3.3 \pm 0.15$  mm in the Playback Mode.

## 3. REC/PB COMBINATION HEAD HEIGHT ADJUSTMENT (Refer to Fig. 56)

- 1) Utilize the cassette tape used in Tape Guide Height Adjustment above, and playback the leader tape part of cassette tape.
- 2) As shown in Fig. 56 adjust head height with screws (c), (d) and (e) until the upper edge of the left channel REC/PB Combination head core.

## 4. REC/PB COMBINATION HEAD AZIMUTH ALIGNMENT ADJUSTMENT

(Refer to Fig. 56)

- 1) The cores of recording and playback heads are mounted in a single head holder to form the recording/playback combination head otherwise known as the Super GX Head. Both recording and playback head cores move when azimuth alignment is adjusted. To obtain optimum playback head core azimuth alignment, follow the instruction 2) – 5) carefully.
- 2) Playback a 10 kHz azimuth alignment adjustment test tape and adjust the adjustment screw (e) until the output levels of both channels are at maximum.
- 3) Invert cassette and see whether there is an output level difference from the above. If there is a difference, repeat 2) and readjust.
- 4) Record a 10 kHz, -20 VU signal from the audio frequency oscillator.
- 5) Rewind and check for any fluctuation in the output level at playback.

## NOTES:

1. Be sure to clean the heads prior to head adjustment.
2. Be careful not to use a magnetized driver or other magnetized tools in the vicinity of the heads.
3. Be sure to demagnetize the heads with a Head Demagnetizer before and after head adjustment.
4. When a mirror installed cassette test tape as shown in Fig. 57 is required, it can be ordered from AKAI Electric Co.
5. The position where spring (a) meets the tape guide base is adjusted at the place of manufacture and readjustment is unnecessary.



## IX. ELECTRICAL ADJUSTMENT

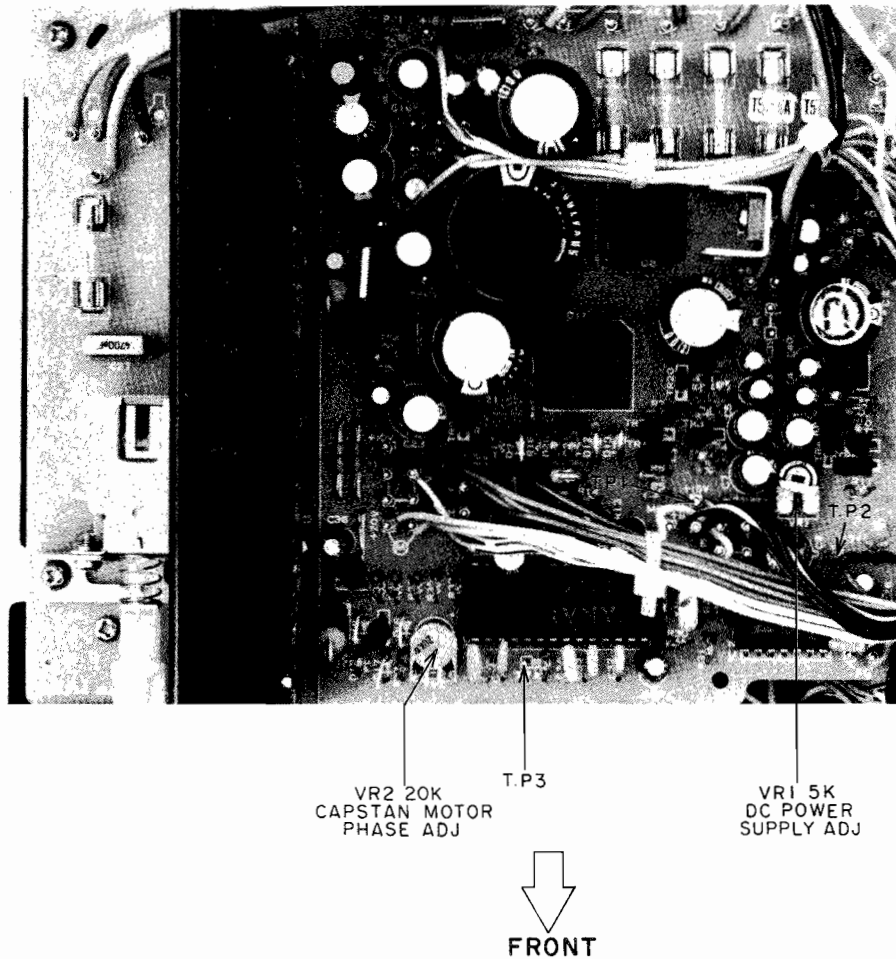

Fig. 59 Power Supply P.C Board (CU-5213)

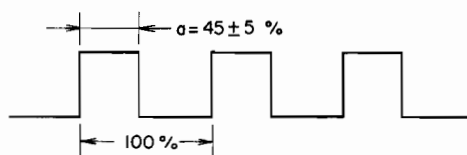

Fig. 60

### 1. DC VOLTAGE ADJUSTMENT

(Refer to Fig. 59)

Connect a Digital Voltmeter or a DC Voltmeter between TP1 ( $\cong +15V$ ) and GND and check the voltage. Check the voltage between TP2 ( $\cong -15V$ ) and GND next and adjust VR1 (5 kohms) to make absolute voltage reading of it exactly equal to that of TP1. Error of the adjustment should be less than  $\pm 0.3V$ .

### 2. CAPSTAN MOTOR PHASE ADJUSTMENT

(Refer to Figs. 59, 60)

Connect an Oscilloscope to TP3 and adjust VR2 (20 kohms) to get a waveform of  $a = 45\% \pm 5\%$  as shown in Fig. 60.

REAR

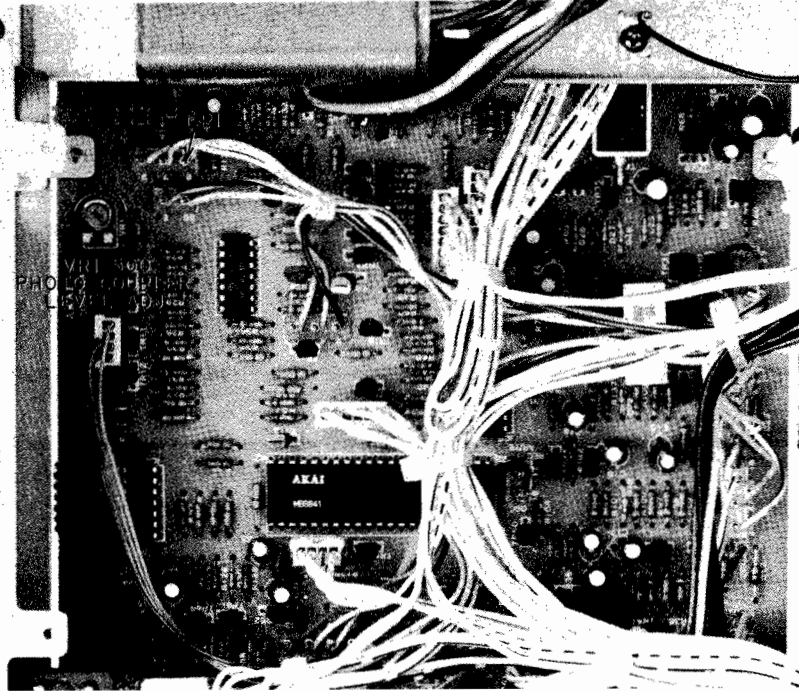

Fig. 61 Syscon P.C Board (CU-5214A)

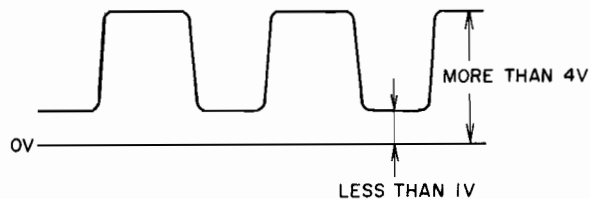

Fig. 62

### 3. PHONO COUPLER LEVEL ADJUSTMENT (Refer to Figs. 61, 62)

- 1) Connect an oscilloscope to TP1 and turn VR1 (500 ohms) on the Syscon P.C Board fully clockwise.
- 2) Remove tape from a cassette pack and prepare an empty pack.  
Set it on the equipment and turn the MODE switch to F. FWD.
- 3) Confirm the waveform on the Oscilloscope is as shown in Fig. 62.
- 4) If the High Level is not more than 4V, adjust VR1 (500 ohms) to get the High Level of 4V.

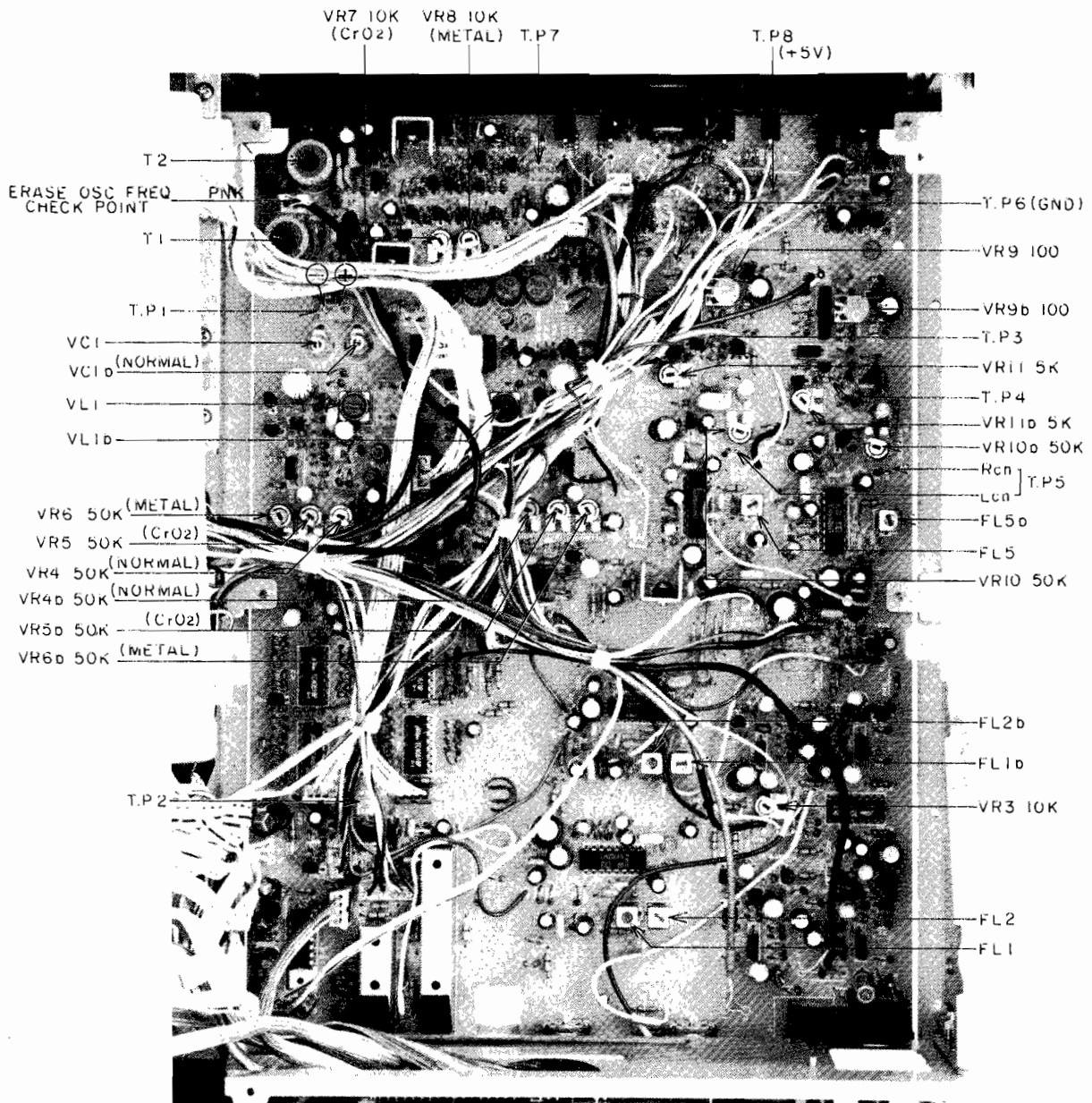

Fig. 63 Pre Amp P.C Board

VR9 100 :	Off-set Voltage Adj.	VC1 55 pF (Normal)	} Freq. Response Adj.
VR10 50K :	PB Level Adj.	VR7 10K (CrO <sub>2</sub> )	
VR11 5K :	PB EQ. Adj.	VR8 10K (Metal)	} REC Level Adj.
VL1 22 mH :	REC Peaking Adj.	VR4 50K (Normal)	
T2 MC-155 :	Erasing OSC Freq. Adj.	VR5 50K (CrO <sub>2</sub> )	
T1 2330-046 :	Bias OSC Coil Tuning Adj.	VR6 50K (Metal)	
FL5 D07-003K :	PB Amp Bias Leak Adj.	FL2 D07-001K :	19 kHz Filter Adj.
FL1 D07-003K :	REC Amp Bias Leak Adj.	VR3 10K :	Auto Tuning Adj.

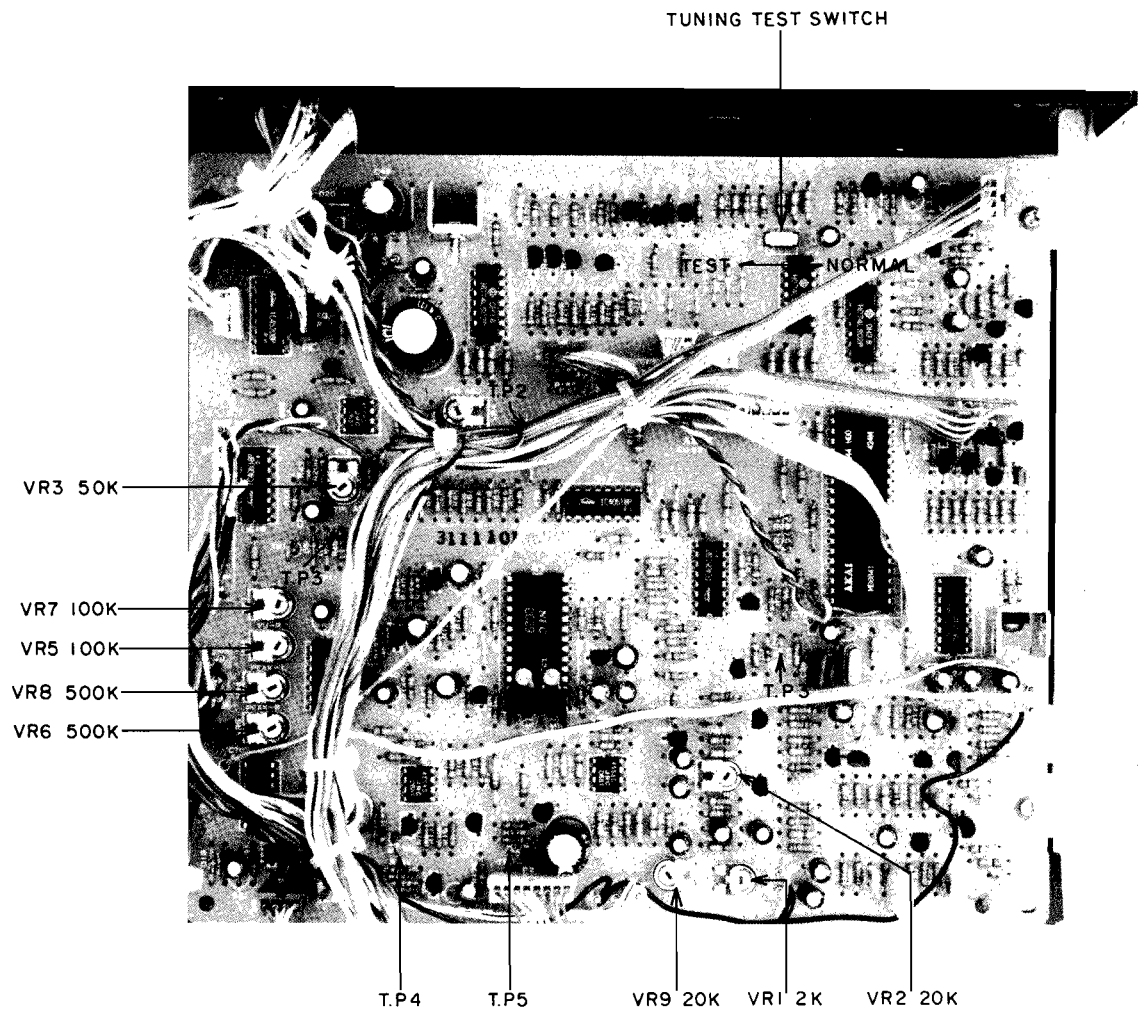

Fig. 64 Tuning P.C Board

- VR7 100K : Lch DC Voltage Adj.
- VR5 100K : Rch DC Voltage Adj.
- VR9 20K : Bar Meter Sens. Adj.
- VR8 500K : Lch Peak Mode Sens. Adj.
- VR6 500K : Rch Peak Mode Sens. Adj.
- VR1 2K : Rch 1 kHz Filter Level Adj.
- VR2 20K : 10 kHz Filter Level Adj.
- VR3 50K : A-D Conversion Voltage Adj.
- VR4 100K : A-D Conversion Voltage Adj.

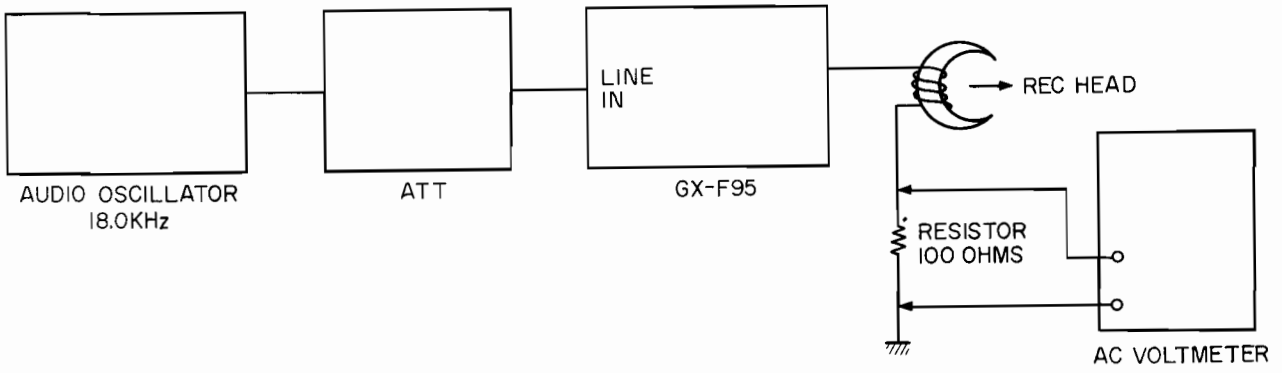

Fig. 65 Instruments Connection

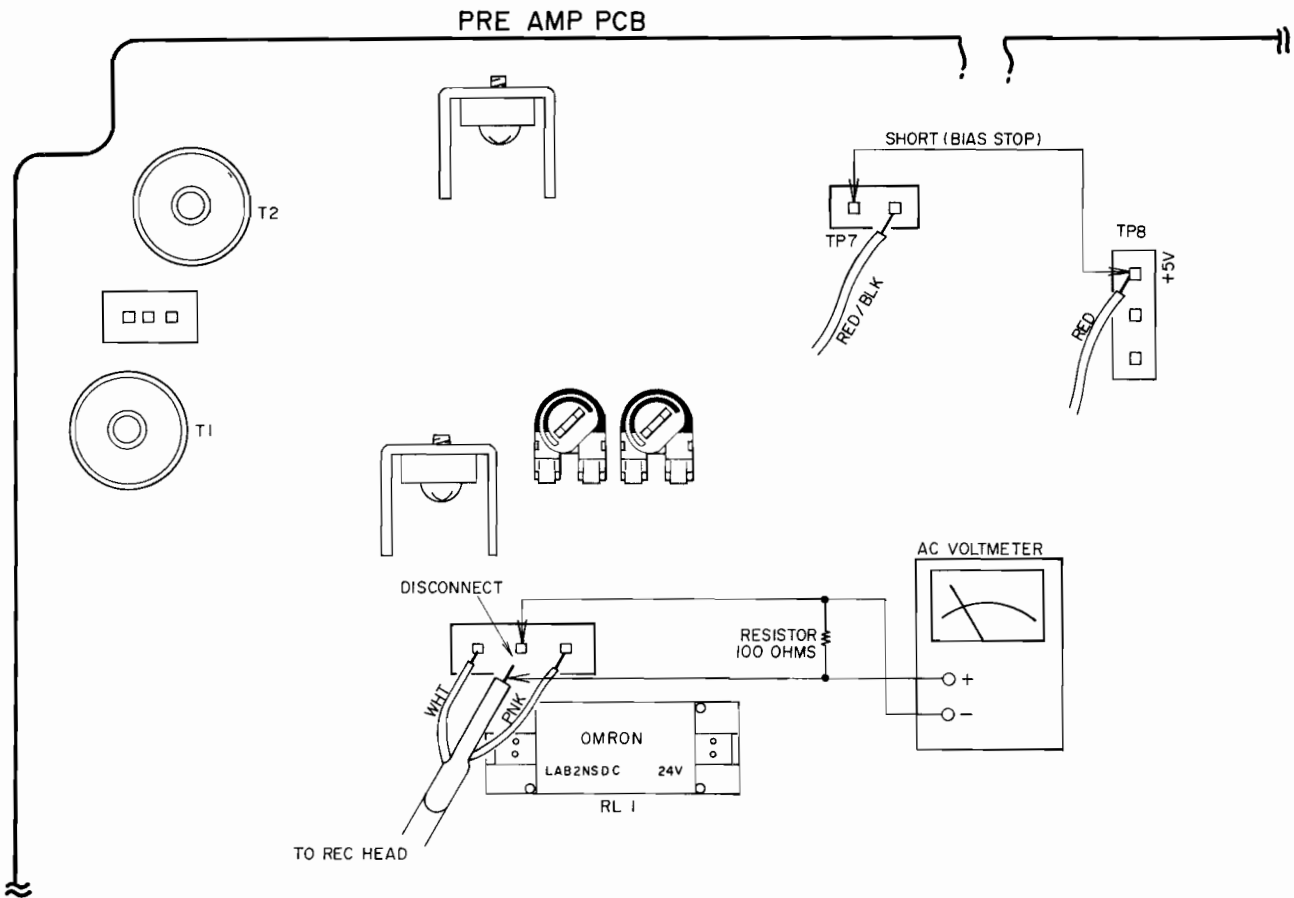

Fig. 66 Rec Peaking Adjustment

#### 4. PRE AMPLIFIER ADJUSTMENT (Refer to Figs. 63, 65, 66)

Step	Adjustment Item	Test Tape Supply Signal	Mode	Adjustment Point	Result	Remarks
1	Off-set Voltage Adjustment	No Signal Input	STOP	VR9 100	0V $\pm$ 0.5V	Connect a Digital Voltmeter between TP3 (Lch) and TP4 (Rch).
2	Playback Level Adjustment	333 Hz 0 VU Test Tape	PLAY	VR10 50K	-5.5 dBm $\pm$ 0.2 dBm (410 mV)	
3	Playback Equalizer Adjustment	10 kHz Test Tape	PLAY	VR11 5K	-19.0 dBm $\pm$ 0.5 dBm	
4	Rec Peaking Adjustment	18.0 kHz from Oscillator	REC	VL1 22 mH	Maximum AC Voltmeter indication	Refer to NOTE 6, 7, 10 and Figs. 65, 66.
5	Erasing Oscillation Circuit Adjustment	No Signal Input	REC	T2 MC-155	100 kHz $\pm$ 2 kHz	Cramp hook up wire of the Erasing Head with a clip over its vinyl insulation and check the frequency by a Frequency Counter. Metal Position.
6	Bias Oscillation Coil Tuning Point Adjustment	No Signal Input	REC	T1 2330-046	Check the voltage by Connection a Tester (2.5V range) to TP1. Turn T1 to adjust the voltage to its dipping point. Metal Position.	
7	Playback Amp Bias Leak Adjustment	No Signal Input	REC	FL5 D07-003K (YLW)	Minimum Output	Set the Monitor Switch to TAPE. Mic, Line Volume at Maximum. Metal Position.
8	Recording Amp Bias Leak Adjustment	No Signal Input	REC	FL1 D07-003K (YLW)	Minimum Output	Set the Monitor Switch to SOURCE Mic, Line Volume at Maximum. Metal Position.
9	Normal Position Frequency Response Adjustment	LH Blank Tape 1,000 Hz, 10,000 Hz -25.5 dBm recording	REC/ PLAY	VC1 5 to 55 pF	1,000 Hz to 10,000 Hz flat response	Set the Tape Selector Switch to AUTO.
10	CrO <sub>2</sub> Position Frequency Response Adjustment	CrO <sub>2</sub> Blank Tape 1,000 Hz, 10,000 Hz -25.5 dBm recording	REC/ PLAY	VR7 10K	1,000 Hz to 10,000 Hz flat response	
11	Metal Position Frequency Response Adjustment	Metal Blank Tape 1,000 Hz, 10,000 Hz -25.5 dBm recording	REC/ PLAY	VR8 10K	1,000 Hz to 10,000 Hz flat response	Set the Tape Selector Switch to MANUAL (Metal)

Step	Adjustment Item	Test Tape Supply Signal	Mode	Adjustment Point	Result	Remarks
12	Recording Level Adjustment	1,000 Hz -5.5 dBm recording	REC/ PLAY	Normal VR4 50K CrO <sub>2</sub> VR5 50K Metal VR6 50K	-5.5 dBm ±0.2 dBm (410 mV)	
13	Distortion Factor Confirmation	1,000 Hz -5.5 dBm Recording	REC/ PLAY	Normal : Less than 0.7% CrO <sub>2</sub> : Less than 0.6% Metal : Less than 0.6%		Refer to NOTE 8.
14	19 kHz Filter Adjustment	19 kHz from an Oscillator	REC	FL2 D07-001K	Minimum AC Voltmeter indication	MPX Filter to ON. Refer to NOTES 9, 10.

- NOTES:**
1. Output Level Control should be at maximum.
  2. Because each of these adjustments are vital to perfect Dolby NR circuit operation, be sure that they are carried out with as little error as possible.
  3. Set Auto Tuning Mode Selector to REFERENCE Mode.
  4. Except for Step 14, set MPX Filter Switch to OFF Position.
  5. Use the following cassette measuring tapes:
 

Normal Tape	:	Maxell	UD	C-60
CrO <sub>2</sub> Tape	:	TDK	SA	C-60
Metal Tape	:	TDK	MA-C	C-60
  6. Stop the recording bias oscillator while making record peaking adjustment (Refer to Figs. 65, 66).
  7. As the same earth line is used for both the Lch and Rch, adjust the Lch with the Rch lead wire (PNK) detached and the Rch with the Lch (WHT) lead wire detached.
  8. If it does not comply with the specifications, repeat Steps 8 to 11 and readjust.
  9. Adjust the oscillator's frequency to give a frequency counter reading of 19.00 kHz.
  10. Unless the core is moved unintentionally this adjustment is not necessary.

## 5. BAR METER ADJUSTMENT (Refer to Figs. 64, 67)

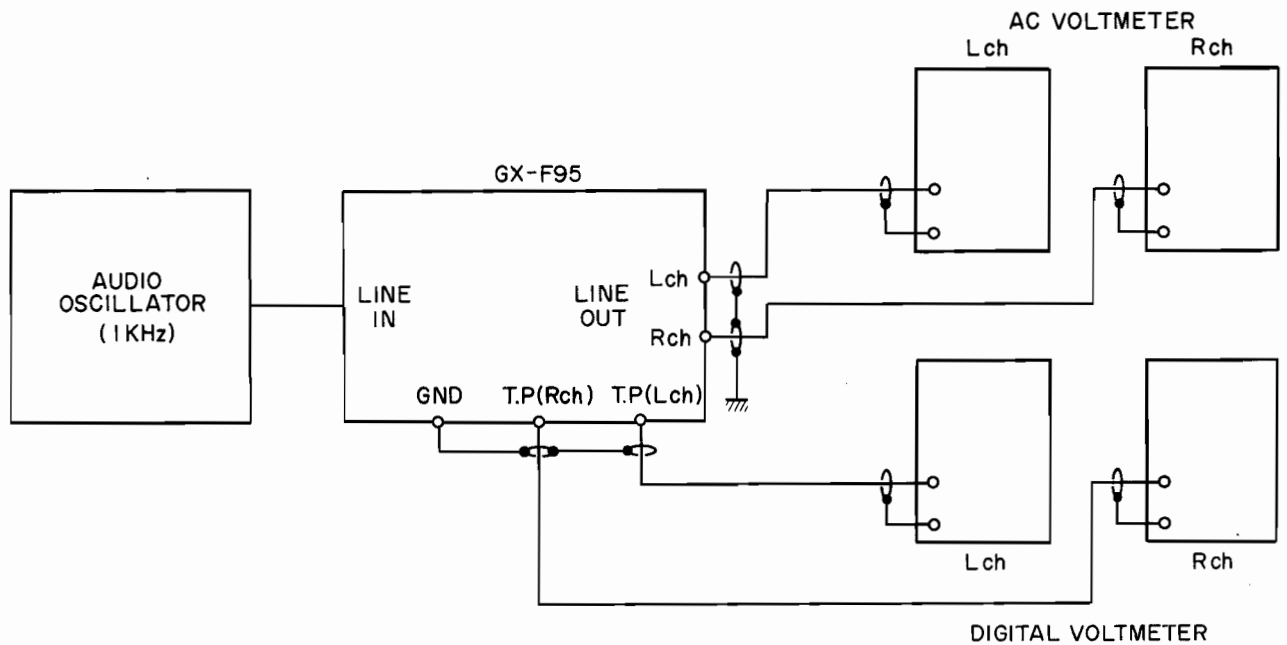

Fig. 67 Instrument Connection

Step	Adjustment Item	Supply Signal	Adjustment Point	Result	Remarks
1	Input Level Setting	1 kHz from an oscillator	LINE REC Volume	-5.5 dBm (410 mV) (LINE OUT)	
2	VU Mode DC Voltage Adjustment	1 kHz from an oscillator	VR7 100K (Lch) VR5 100K (Rch) (Tuning PCB)	1.52V ± 0.05V (TP Output)	Set the PEAK/VU button to VU. Connect a Digital Voltmeter between TP4 (Lch) and TP5 (Rch).
3	Bar Meter Sensitivity Adjustment	1 kHz from an oscillator	VR9 20K (Tuning PCB)	0 dB indication (Bar Meter)	Turn off the segment of 0 dB once and adjust it to the position where it completely lights.
4	Peak Mode Sensitivity Adjustment	1 kHz from an oscillator	VR8 500K (Lch) VR6 500K (Rch) (Tuning PCB)	-7 dB indication (Bar Meter)	Set the PEAK/VU button to PEAK. Turn off the segment of -7 dB once and adjust it to the position where it completely lights.

- NOTES:**
1. Adjust when 3 secs have elapsed after the power is switched ON.
  2. Put the monitor switch to SOURCE and the output volume to Maximum.



---

## 6. AUTO TUNING ADJUSTMENT

(Refer to Figs. 63, 64)

- 1) Set the Tuning Test Switch of the Tuning P.C Board to TEST.
- 2) Connect TP2 (Mute release point) of the Pre Amp P.C Board to GND to release muting.
- 3) Set the square output of the Audio Oscillator to  $1\text{ kHz} \pm 2\text{ Hz}$ ,  $4\text{ Vp-p}$  and apply it to TP3 of the Tuning P.C Board.
- 4) With this condition adjust VR1 (2 kohms) of the Tuning P.C Board to get an output of Rch Line Out of  $-25.5\text{ dBm}$  ( $41\text{ mV}$ )  $\pm 0.2\text{ dBm}$ .
- 5) Then adjust VR3 (10 kohms) of Pre Amp P.C Board to get the output of Lch Line Out of  $-25.5\text{ dBm}$  ( $41\text{ mV}$ )  $\pm 0.2\text{ dBm}$ .
- 6) Set the Square Wave output of the Audio oscillator to  $10\text{ kHz} \pm 50\text{ Hz}$ ,  $4\text{ Vp-p}$ .
- 7) Adjust VR2 (20 kohms) of the Tuning P.C Board to get a Line Out output levels of  $-25.5\text{ dBm}$  ( $41\text{ mV}$ )  $\pm 0.2\text{ dBm}$  for both of Lch and Rch.  
If these output levels cannot be adjusted to the specified value, restart adjustment from step 3).
- 8) Set Square Wave Output of Audio Oscillator to  $6.3\text{ kHz} \pm 100\text{ Hz}$ ,  $4\text{ Vp-p}$  and confirm the Line Out output levels of both of Lch and Rch are at  $-24.5\text{ dBm}$  ( $46\text{ mV}$ )  $\pm 0.2\text{ dBm}$ .
- 9) Turn Monitor Switch to TAPE, set Sine Wave Output of the Audio Oscillator to  $1\text{ kHz} \pm 2\text{ Hz}$  and apply it to TP5 of the Pre Amp P.C Board. GND terminal of the Audio Oscillator has to be connected to TP6.  
(Should output signal not be available at any stage of the following adjustment, turn off the power source once to get the Microcomputer to the Reset state and restart the adjustments.)
- 10) Adjust output level of the Audio Oscillator to get Line Out Output of  $-25.0\text{ dBm}$  ( $41\text{ mV}$ )  $\pm 0.2\text{ dBm}$ .
- 11) Connect a Digital Voltmeter to TP1 of the Tuning P.C Board and adjust VR3 (50 kohms) of the Tuning P.C Board to get a voltage of  $180\text{ mV} \pm 5\text{ mV}$ .  
GND of the Digital Voltmeter is to be connected as close to TP1 as possible.
- 12) Disconnect the Mute Release Wiring connected at step 2 and turn the Tuning Test Switch to NORMAL.
- 13) Connect a Digital Voltmeter to TP2 of the Tuning P.C Board and adjust VR4 (100 kohms) of the Tuning P.C Board to get a voltage of  $180\text{ mV} \pm 5\text{ mV}$ .

### NOTES:

1. Output Level Control should be at maximum.
2. Set Dolby NR Switch to OFF Position.
3. Use an accurate Audio Oscillator of which oscillation frequency will not change during adjustments.

## X. DC RESISTANCE OF VARIOUS COILS

Parts	Designation	DC Resistance
Recording/Playback Head	PR4-3	Playback: 250 ohms $\pm$ 10% Recording: 22.5 ohms
Erase Head	E-921-PQ-0201	1.6 ohms $\pm$ 20%
Play Plunger Solenoid	1240PHT1	100 ohms $\pm$ 10%
Pause Plunger Solenoid	1037THT1	100 ohms $\pm$ 10%
Brake Plunger Solenoid	0730PHT7	150 ohms $\pm$ 10%
Relay	LAB2NS DC24V	1750 ohms $\pm$ 10%

## XI. CLASSIFICATION OF VARIOUS P.C BOARDS

### 1. P.C BOARD TITLE AND IDENTIFICATION NUMBERS

P.C Board Title	P.C Board Number
Pre Amp P.C Board	CU-5212A
Head Phone Jack P.C Board	CU-5212B
Power Supply P.C Board	CU-5213
Syscon P.C Board	CU-5214A
Remote Control P.C Board	CU-5214B
Tuning P.C Board	CU-5215
Bar Meter P.C Board	CU-5216
Counter P.C Board	CU-5217
Door Switch P.C Board	CU-3228
Motor P.C Board	CU-7007
Detector P.C Board	UCF-1520
Integrated P.C Board	CU-5219

## 2. COMPOSITION OF VARIOUS P.C BOARDS

### 1) PRE AMP P.C BOARD CU-5212A (2ED) and HEAD PHONE P.C BOARD CU-5212B

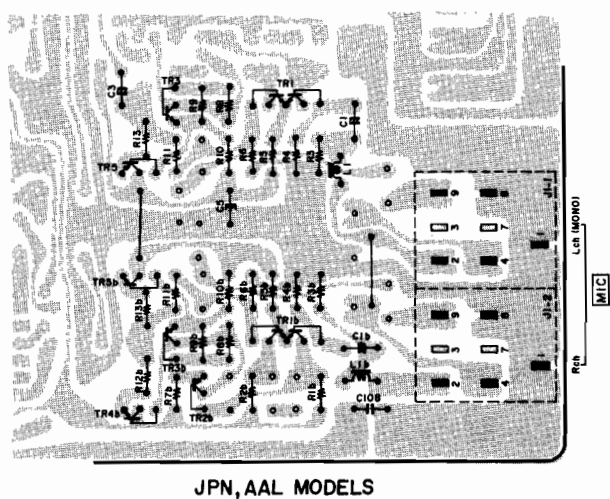
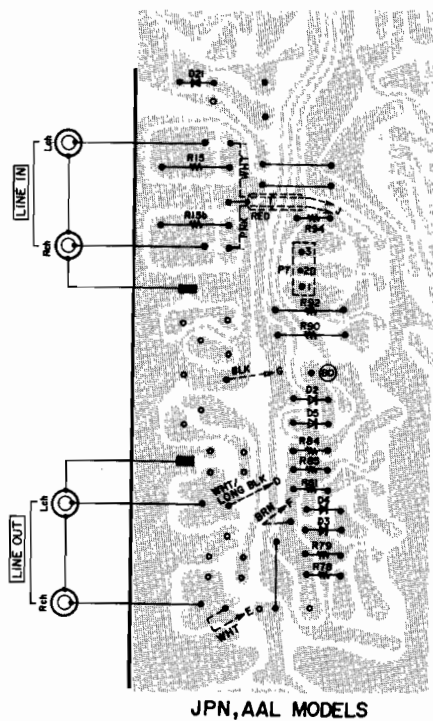

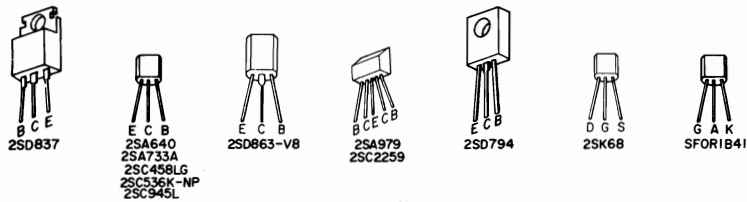

\* REFERENCE REC MODE

	NORMAL	CrO2	METAL
TR28	B 7.7V	9.8V	14.8V
	C 23.0V	23.0V	23.0V
	E 7.1V	9.2V	14.2V
TR27	B 6.4V	8.6V	13.6V
	B 0.2V	0V	-0.2V
	C 6.4V	8.5V	13.5V
TR30,31	E 0.1V	0.1V	0.2V
T1	Ⓞ 64.7V AC	92.0V AC	135.8V AC
	Ⓛ 18.0V AC	26.1V AC	38.5V AC

	NORMAL	CrO2	METAL
TR43	B 9.2V	12.8V	17.8V
	C 23.0V	23.0V	23.0V
	E 6.7V	12.2V	17.2V
TR42	B 8.1V	11.6V	16.6V
	B 0.6V	0.7V	0.7V
	C 8.1V	11.6V	16.6V
TR44,45	E 0.2V	0.3V	0.4V
T2	Ⓞ 14.7V AC	21.4V AC	30.0V AC
	Ⓛ 13.7V AC	18.5V AC	30.0V AC

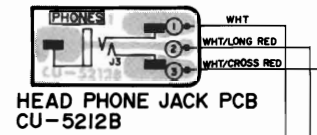

PRE AMP PCB CU-5212A

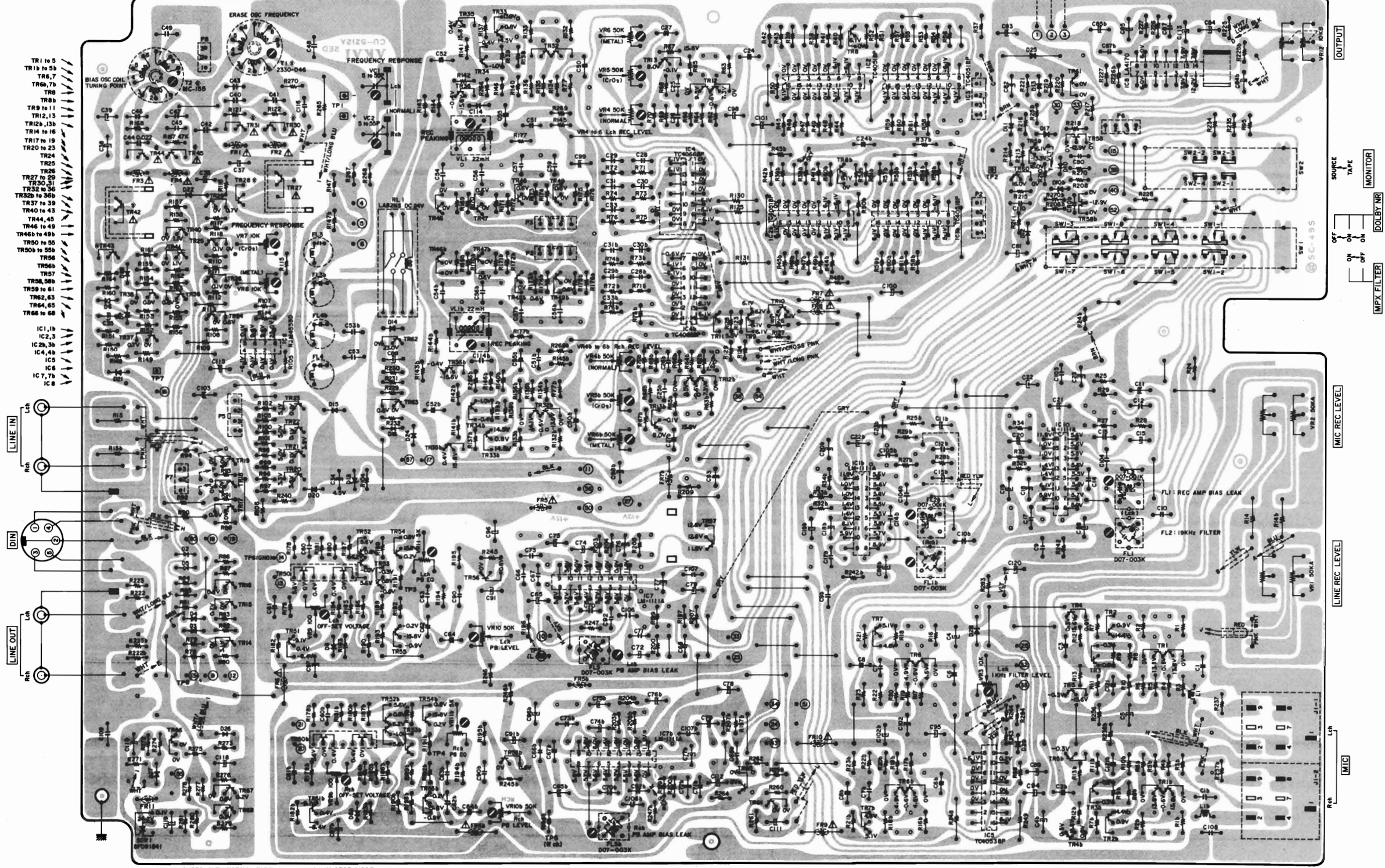

- TR1 to 5
- TR18 to 19
- TR6,7
- TR8
- TR9
- TR10 to 11
- TR12,13
- TR14 to 16
- TR17 to 19
- TR20 to 23
- TR24
- TR25
- TR26
- TR27 to 29
- TR30,31
- TR32 to 36
- TR38 to 39
- TR40 to 43
- TR44,45
- TR46 to 49
- TR48 to 49
- TR50 to 55
- TR58 to 59
- TR56
- TR58
- TR58,59
- TR59 to 61
- TR62,63
- TR64,65
- TR66 to 68
- IC1,18
- IC2,3
- IC28,35
- IC4,41
- IC5
- IC6
- IC7,79
- IC8

VOLTAGE MEASURED WITH NORMAL TAPE IN AND DECK IN STOP MODE

WARNING: Δ INDICATES SAFETY CRITICAL COMPONENTS. FOR CONTINUED SAFETY, REPLACE SAFETY CRITICAL COMPONENTS ONLY WITH MANUFACTURER'S RECOMMENDED PARTS.  
 AVERTISSEMENT: Δ IL INDIQUE LES COMPOSANTS CRITIQUES DE SÛRETÉ. POUR MAINTENIR LE DEGRÉ DE SÛRETÉ DE L'APPAREIL, NE REMPLACER LES COMPOSANTS DONT LE FONCTIONNEMENT EST CRITIQUE POUR LA SÛRETÉ QUE PAR DES PIÈCES RECOMMANDÉES PAR LE FABRICANT.

- TR1, 6, 12, 32 ..... 25C2259 (F,G)
- TR2, 7, 13, 33 ..... 25A640 (E,F)
- TR3, 34, 51, 53 ..... 25C458L (G,D)
- TR4, 35, 46 to 49, 54, 56, 64, 65 ..... 25C458L (PA,DA)
- TR5, 9 to 11, 20 to 23, 36, 55, 58 ..... 25A733A (P,Q)
- TR6, 14 to 19, 24 to 26, 28, 29, 37 to 41, 43, 60 to 63, 66 to 68 ..... 25C536K-NP (E,F)
- TR27, 42 ..... 25D794 (P,Q)
- TR30, 31, 44, 45 ..... 25D863-V8 (F)
- TR50 ..... 25K150 (GR)
- TR52 ..... 25A979 (F,G)
- TR58 ..... 25K68 (M,N)
- TR57 ..... 25D837 (P,Q)



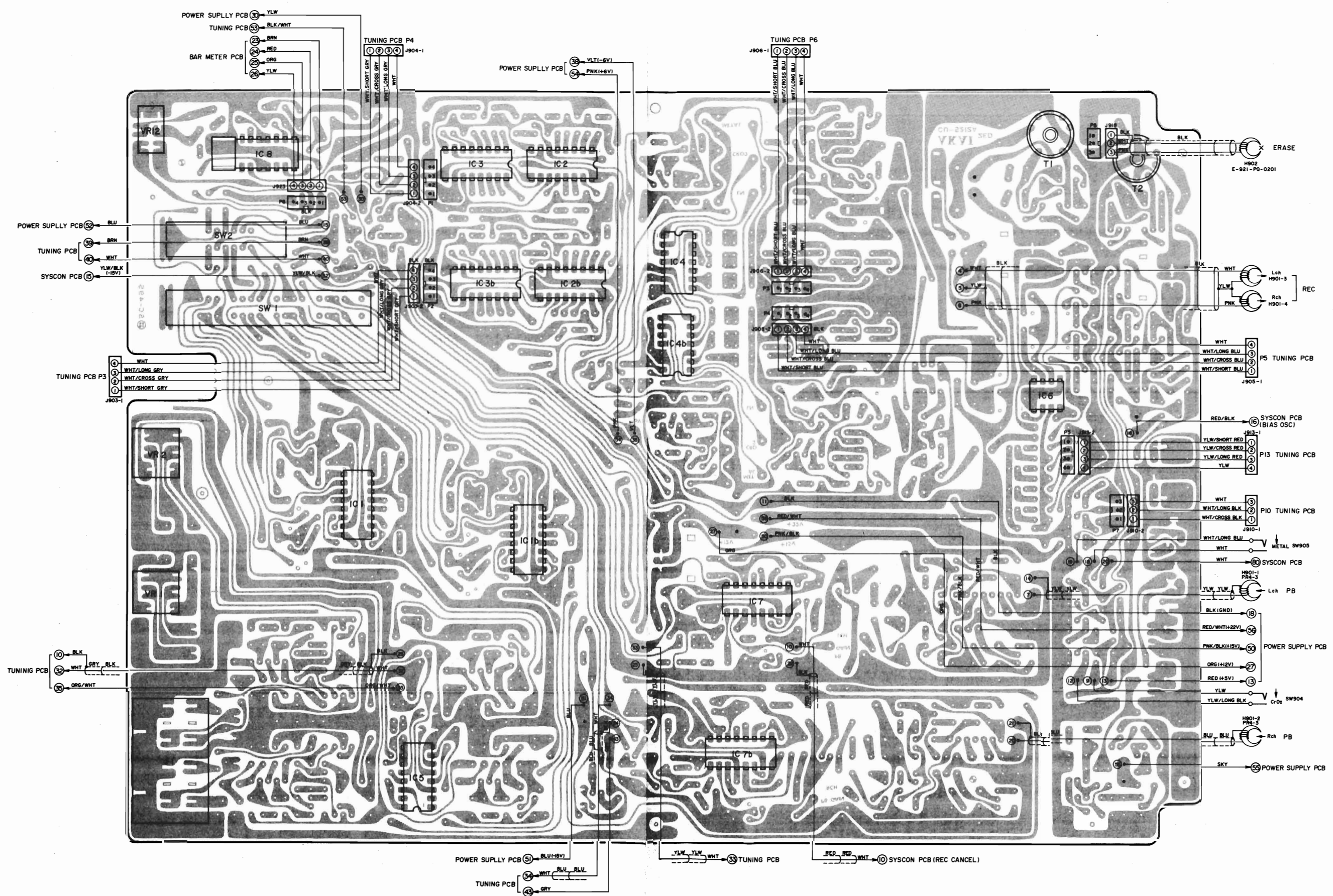

2) TUNING P.C BOARD CU-5215 (2ED)

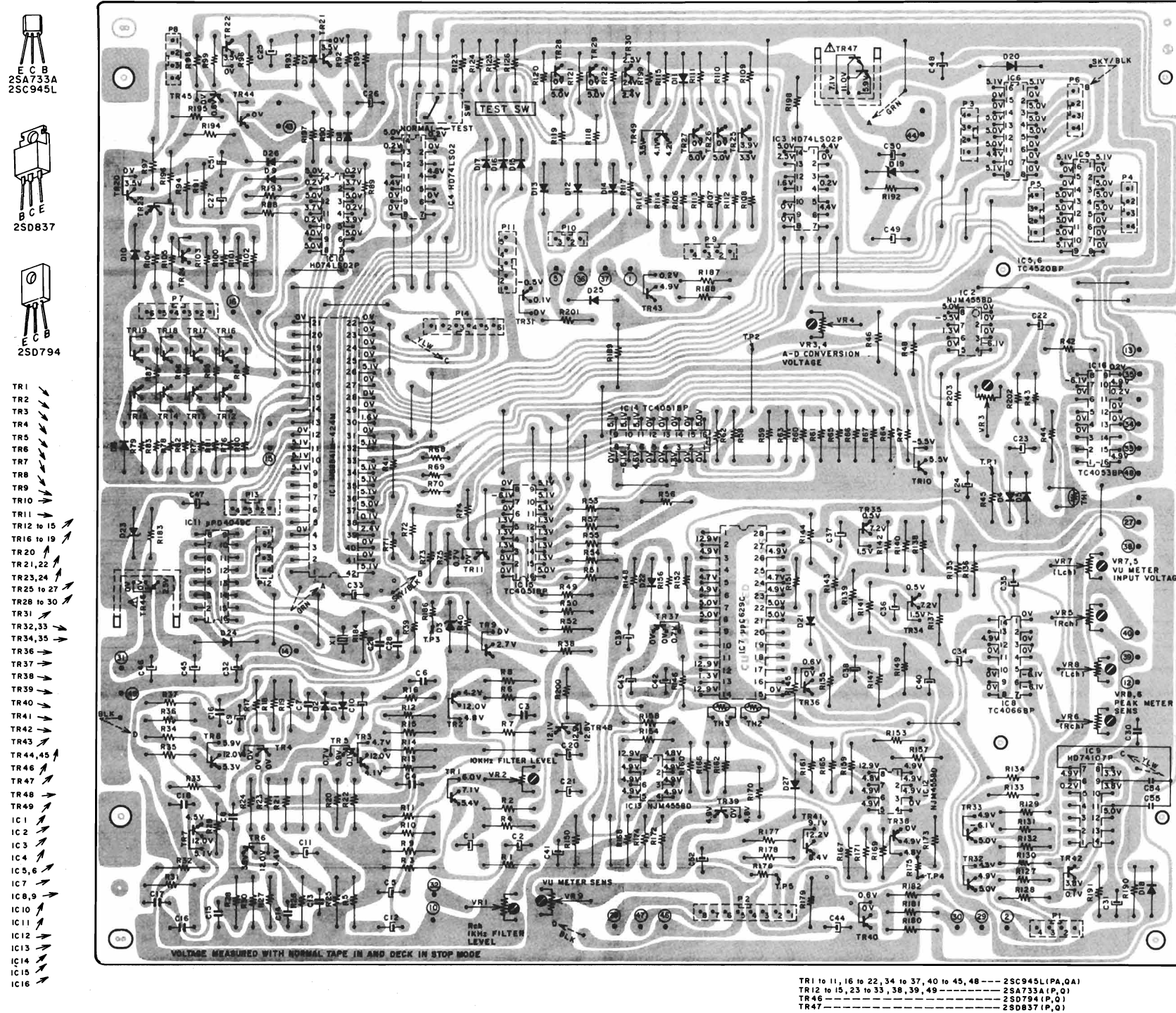



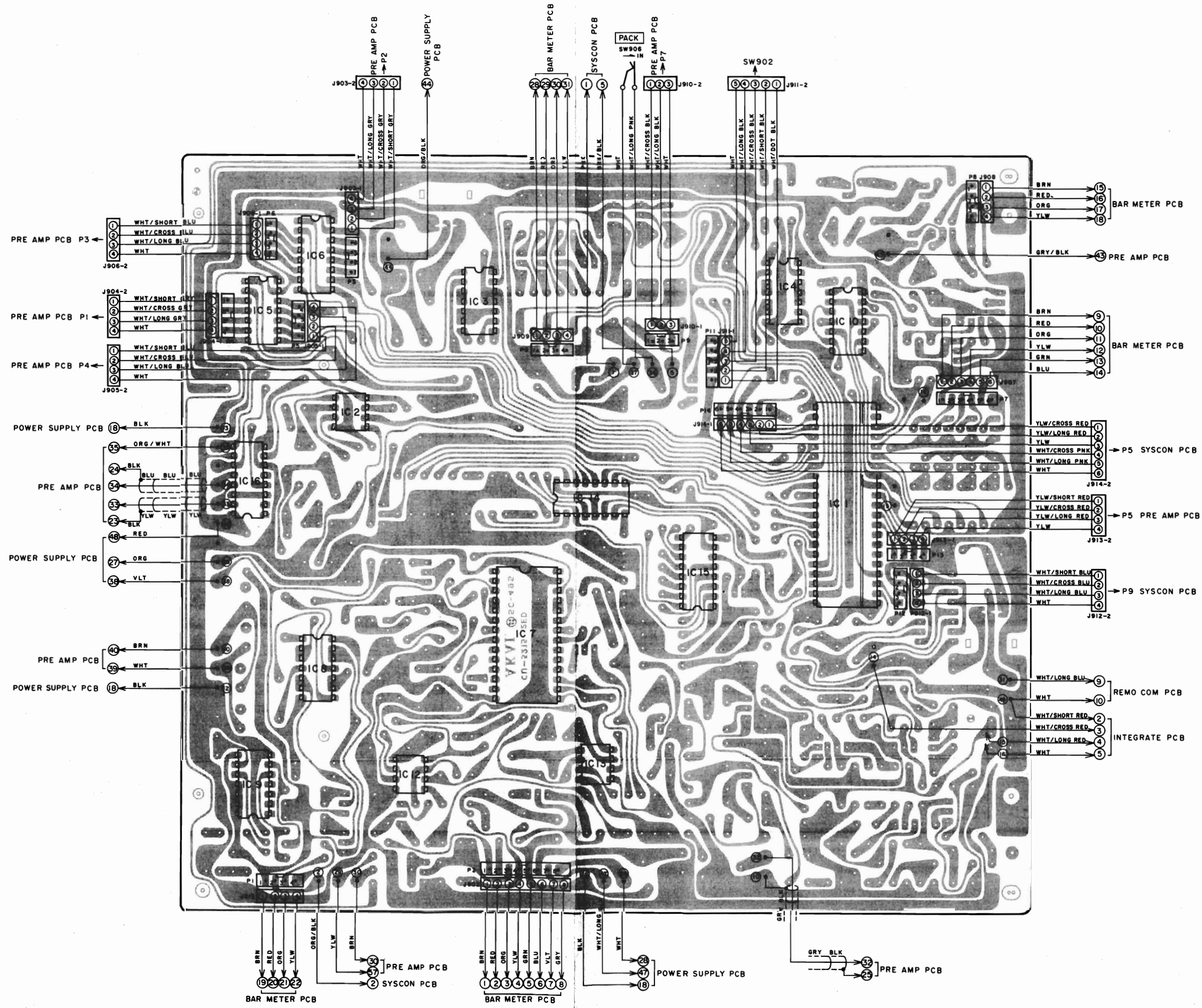

3) SYSCON P.C BOARD CU-5214A and DETECTOR P.C BOARD UCF-1520

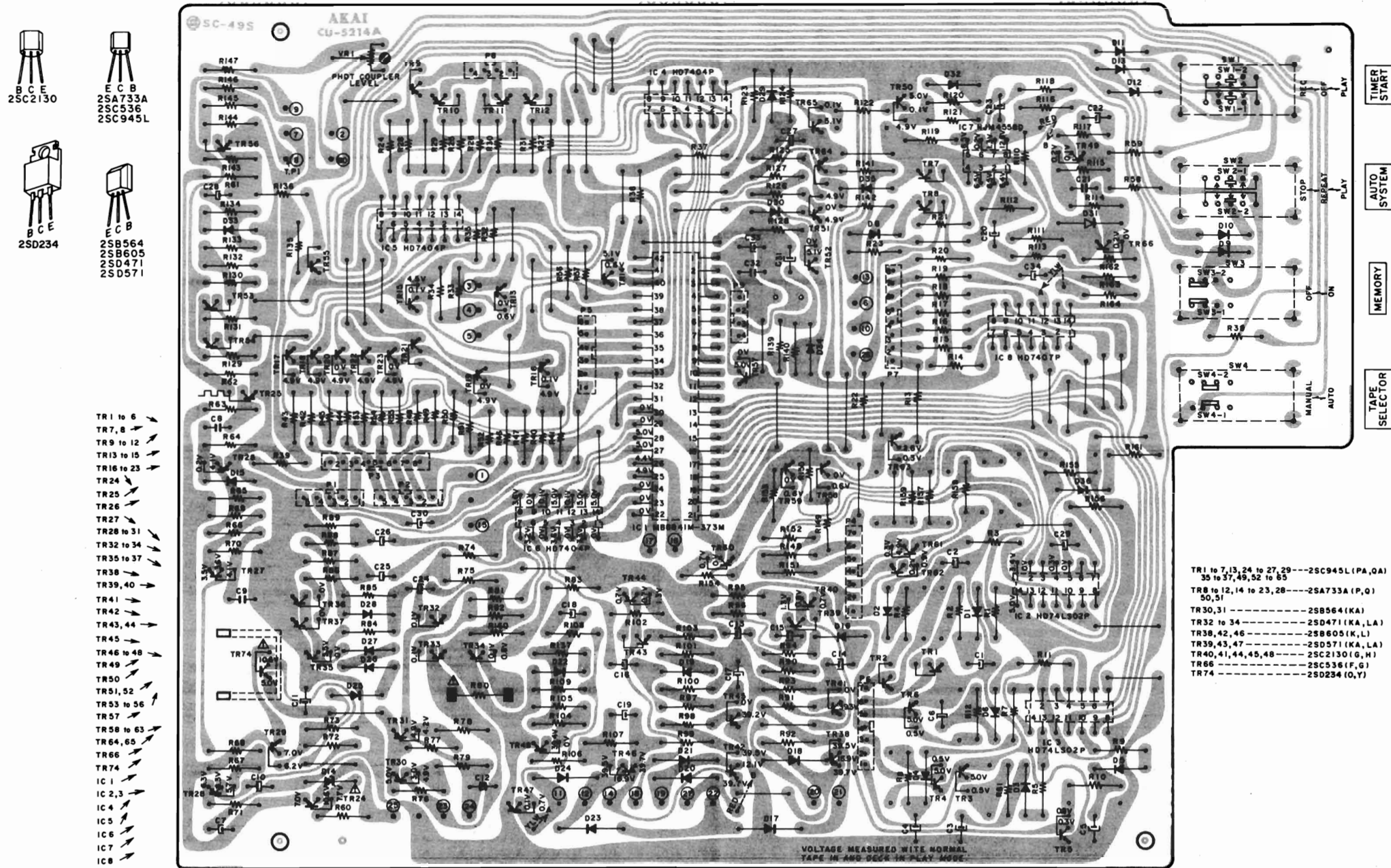

WARNING: Δ INDICATES SAFETY CRITICAL COMPONENTS. FOR CONTINUED SAFETY, REPLACE SAFETY CRITICAL COMPONENTS ONLY WITH MANUFACTURER'S RECOMMENDED PARTS.

AVERTISSEMENT: Δ IL INDIQUE LES COMPOSANTS CRITIQUES DE SÛRETÉ. POUR MAINTENIR LE DEGRÉ DE SÛRETÉ DE L'APPAREIL, NE REMPLACER LES COMPOSANTS DONT LE FONCTIONNEMENT EST CRITIQUE POUR LA SÛRETÉ QUE PAR DES PIÈCES RECOMMANDÉES PAR LE FABRICANT.



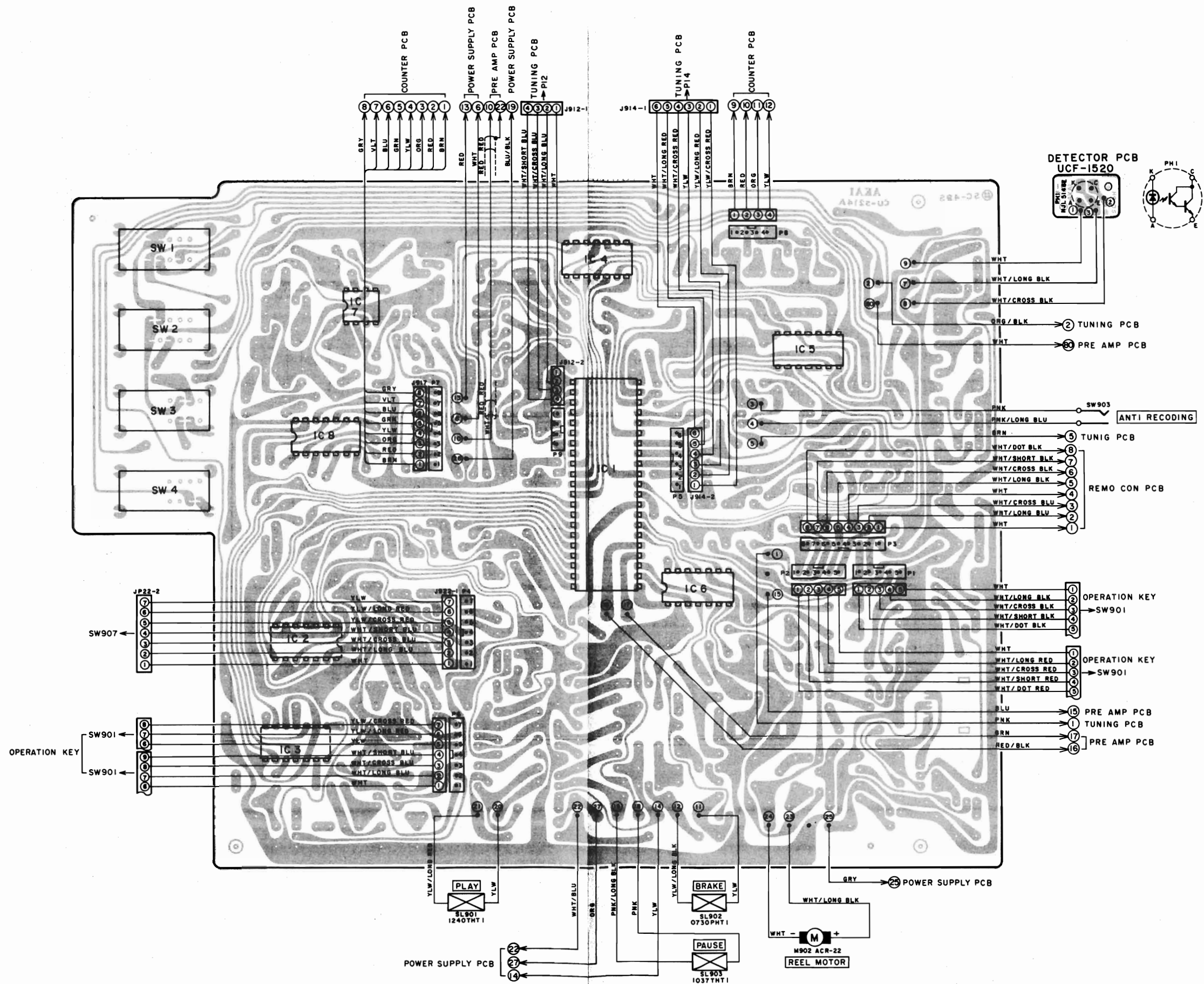

4) POWER SUPPLY P.C BOARD CU-5313 (2ED)

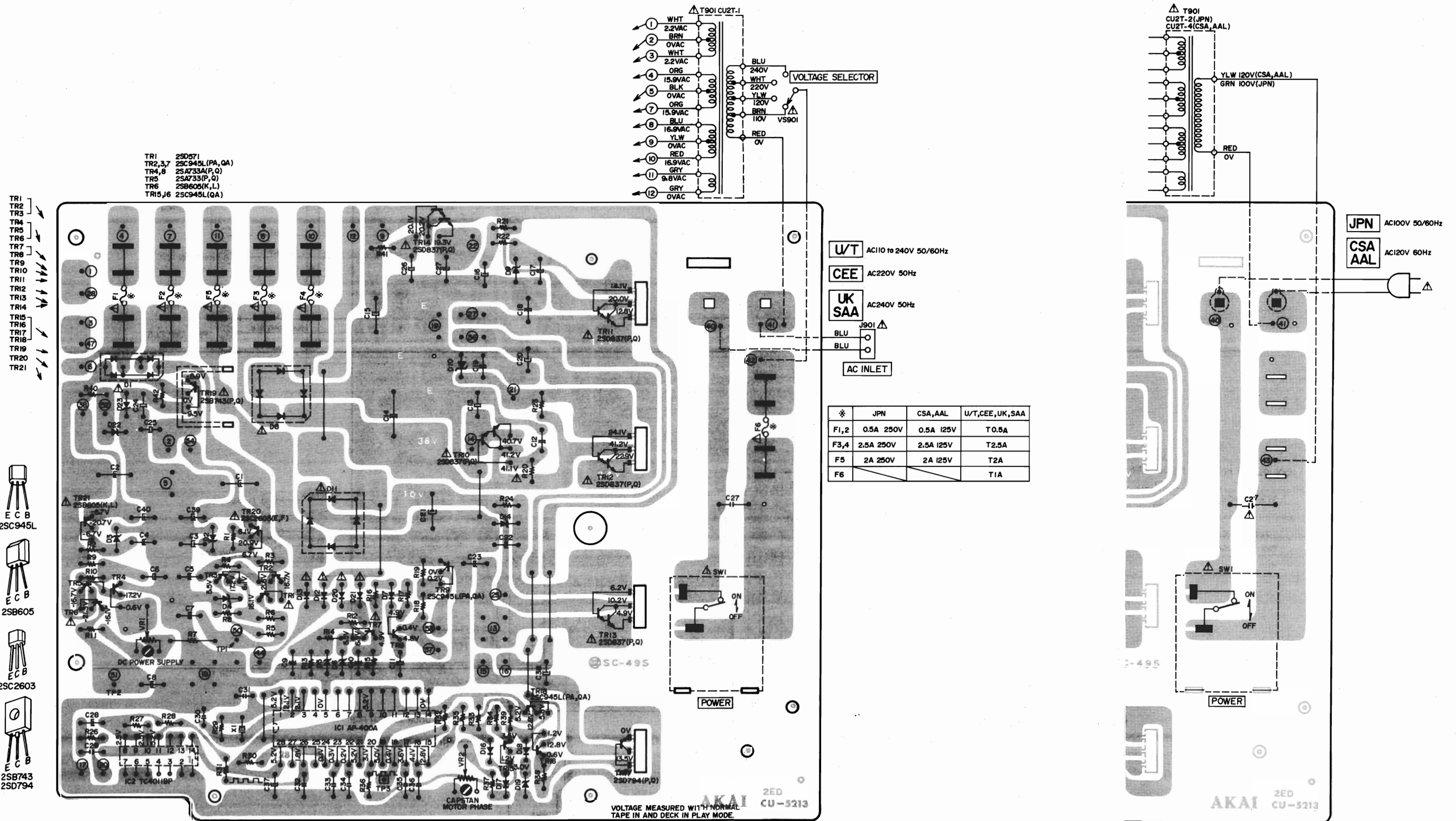

WARNING: Δ INDICATES SAFETY CRITICAL COMPONENTS. FOR CONTINUED SAFETY, REPLACE SAFETY CRITICAL COMPONENTS ONLY WITH MANUFACTURER'S RECOMMENDED PARTS.  
 AVERTISSEMENT: Δ IL INDIQUÉ LES COMPOSANTS CRITIQUES DE SÛRETÉ. POUR MAINTENIR LE DEGRÉ DE SÛRETÉ DE L'APPAREIL NE REMPLACER LES COMPOSANTS DONT LE FONCTIONNEMENT EST CRITIQUE POUR LA SÛRETÉ QUE PAR DES PIÈCES RECOMMANDÉES PAR LE FABRICANT.

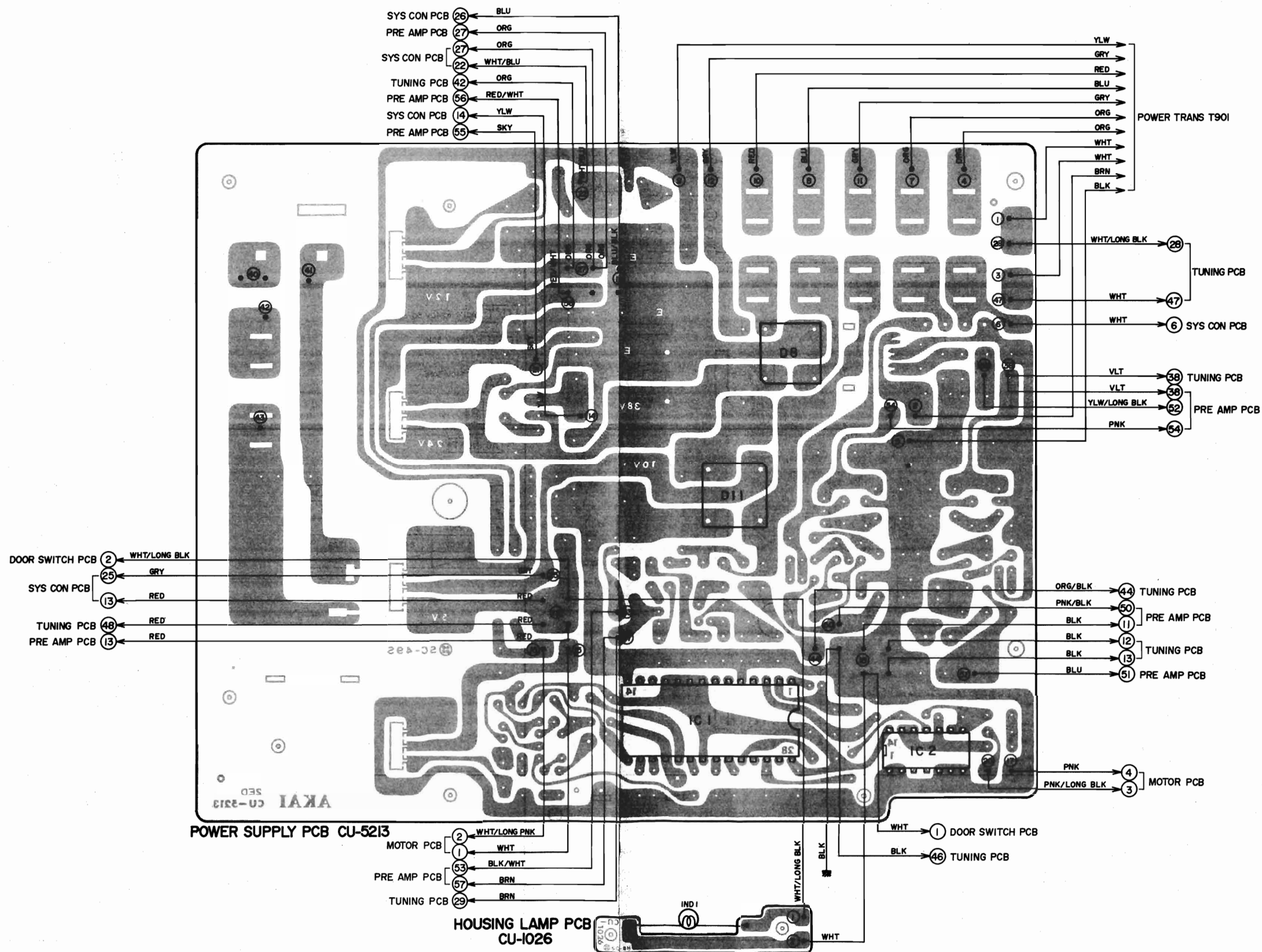

5) BAR METER P.C BOARD CU-5216 (2ED)

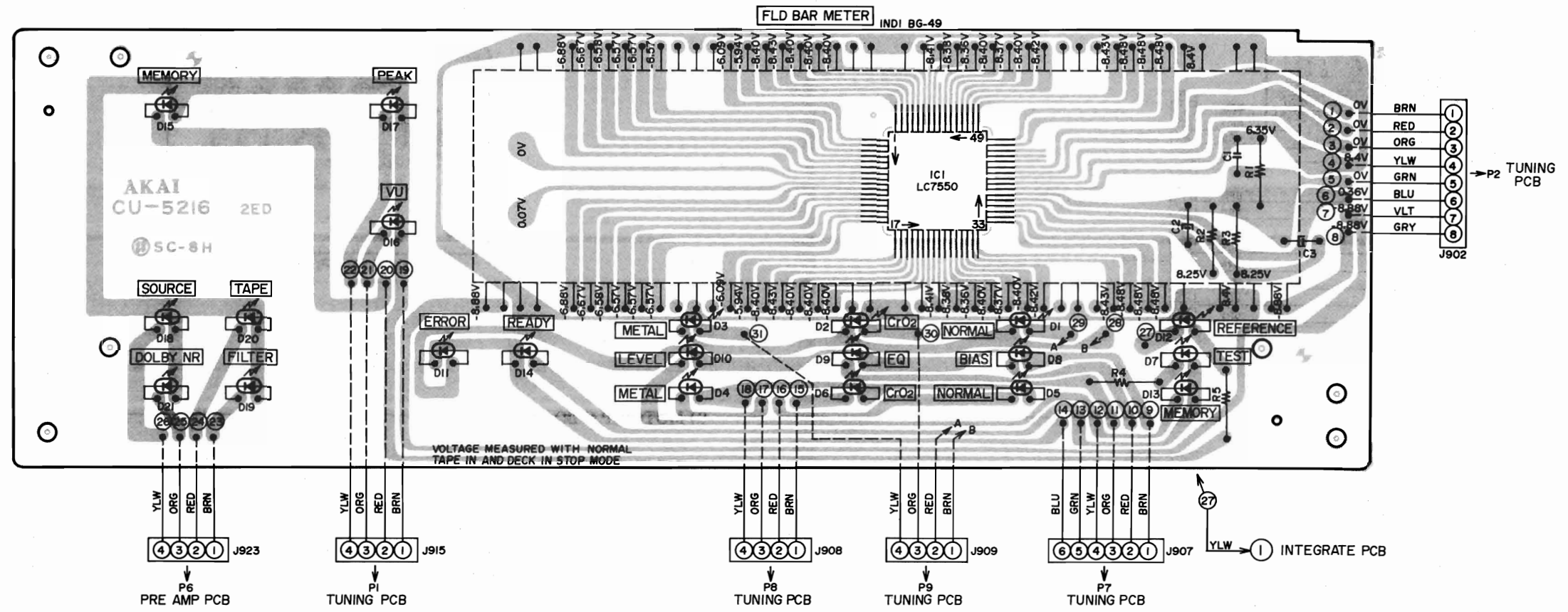



6) COUNTER P.C BOARD CU-5217

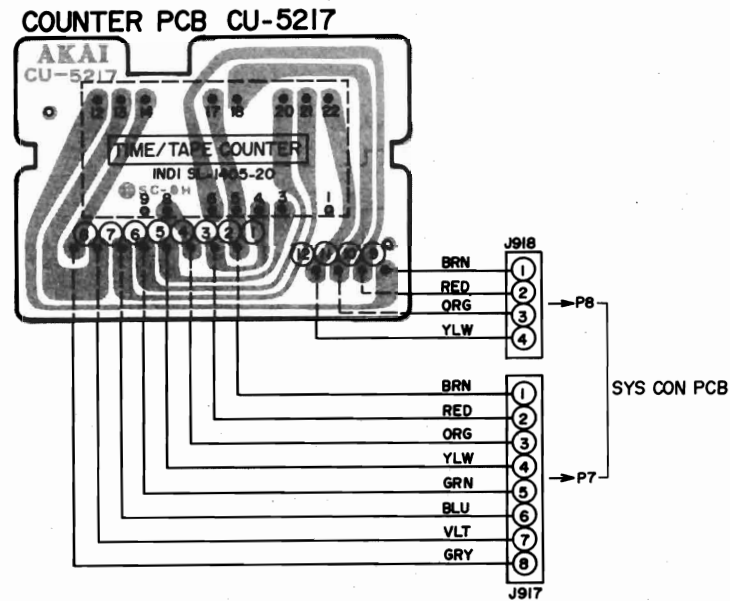

7) DOOR SWITCH P.C BOARD CU-3228

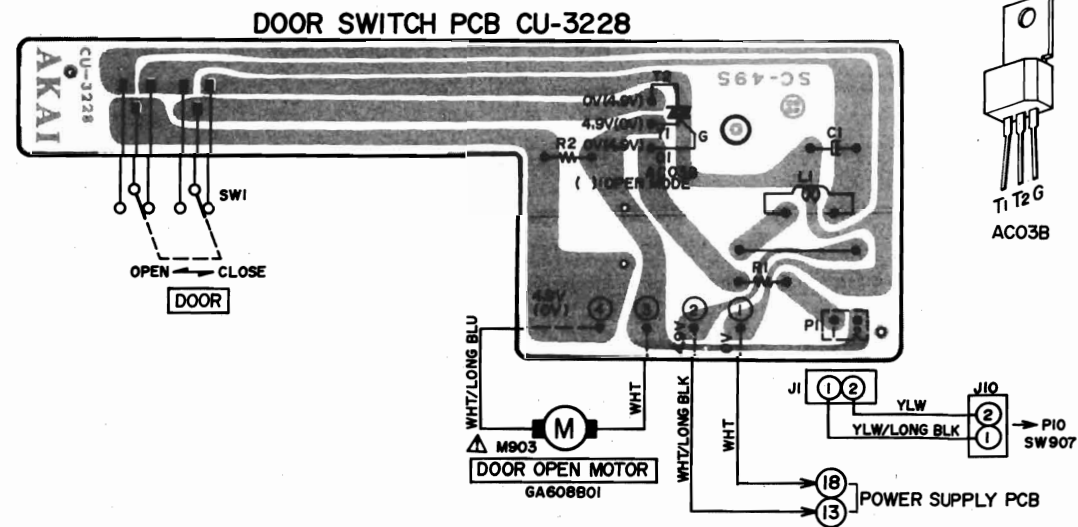

WARNING: Δ INDICATES SAFETY CRITICAL COMPONENTS. FOR CONTINUED SAFETY, REPLACE SAFETY CRITICAL COMPONENTS ONLY WITH MANUFACTURER'S RECOMMENDED PARTS.  
AVERTISSEMENT: Δ IL INDIQU LES COMPOSANTS CRITIQUES DE SÛRETÉ. POUR MAINTENIR LE DEGRÉ DE SÛRETÉ DE L'APPAREIL, NE REMPLACER LES COMPOSANTS DONT LE FONCTIONNEMENT EST CRITIQUE POUR LA SÛRETÉ QUE PAR DES PIÈCES RECOMMANDÉES PAR LE FABRICANT.

8) INTEGRATED P.C BOARD CU-5219

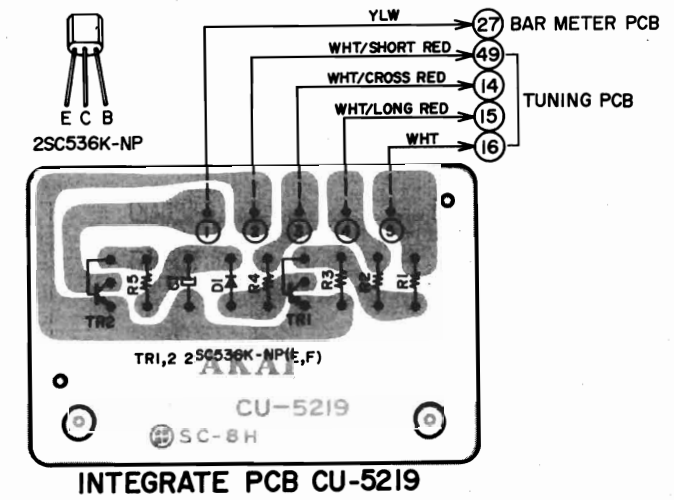

9) MOTOR P.C BOARD CU-7007

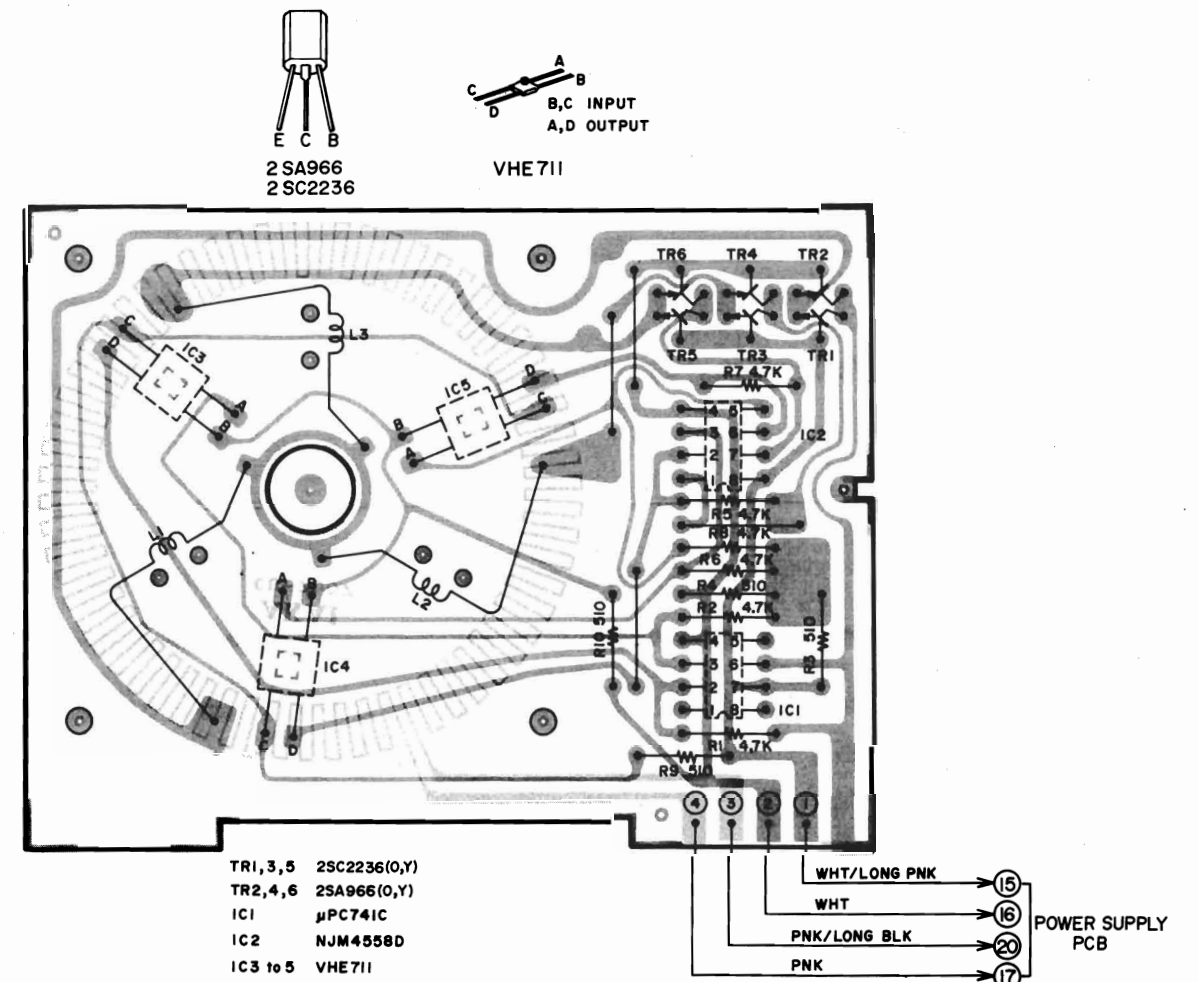

10) REMOTE CONTROL P.C BOARD CU-5214B

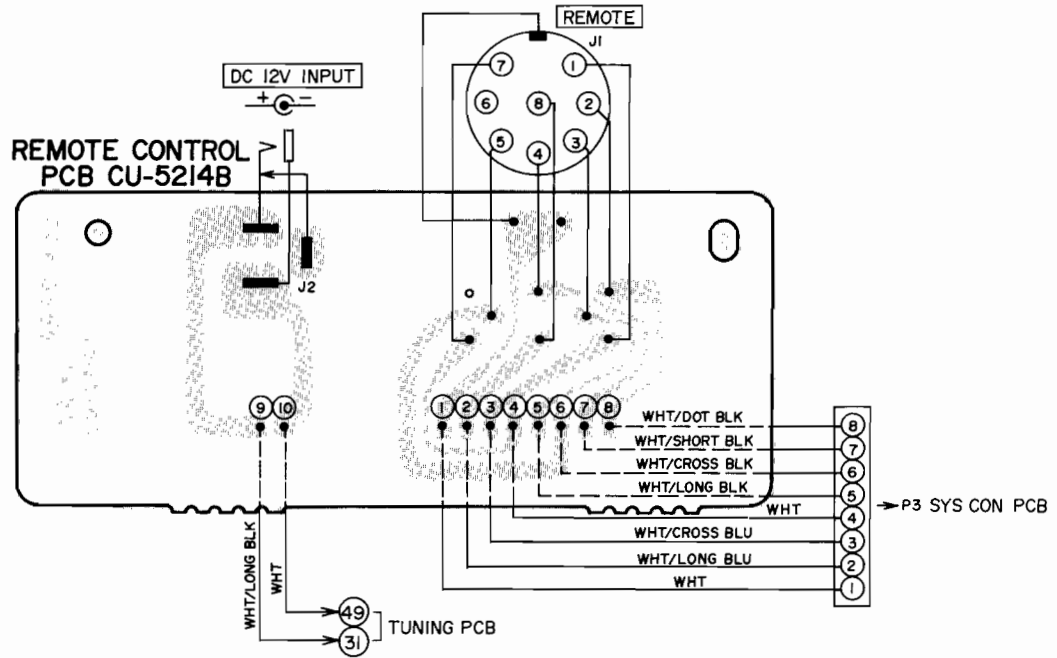

MEMO

---





MEMO

---



MEMO

---

---

SECTION 2

**PARTS LIST**

TABLE OF CONTENTS

1. RECOMMENDED SPARE PARTS .....	73
2. HEAD BASE BLOCK .....	75
3. SUB FRAME BLOCK .....	76
4. MECHA BLOCK .....	78
5. EJECTOR BLOCK .....	80
6. PRE AMP P.C BOARD BLOCK .....	81
7. SYS. CON. P.C BOARD (CU-5214A) BLOCK .....	82
8. AUTO TUNING P.C BOARD BLOCK .....	82
9. POWER SUPPLY P.C BOARD BLOCK .....	83
10. BAR METER P.C BOARD BLOCK .....	83
11. COUNTER P.C BOARD BLOCK .....	83
12. INTEGRAL P.C BOARD BLOCK .....	83
13. MOTOR P.C BOARD BLOCK .....	83
14. DOOR OPEN P.C BOARD BLOCK .....	83
15. ASSEMBLY BLOCK (1) .....	84
16. ASSEMBLY BLOCK (2) .....	85
17. FINAL ASSEMBLY BLOCK .....	86
INDEX .....	86

Resistor and Capacitor which is not listed in this parts list, please refer to COMMON LIST FOR SERVICE PARTS.

## HOW TO USE THIS PARTS LIST

1. This parts list is compiled by various individual blocks based on assembly process.
2. When ordering parts, please describe parts number, serial number, and model number in detail.
3. How to read List

The reference number corresponds with illustration or photo number of that particular parts list.

This number corresponds with the Figure Number.

This number corresponds with the individual parts index number in that figure.

A small "x" indicates the inability to show that particular part in the Photo or Illustration.

**12-115x**

Ref. No.	Parts No.	Description
<b>FLYWHEEL BLOCK #13</b>		
12-115x	800425	Flywheel Block Assy. Comp.
12-116	244506	Flywheel Only
12-117x	244754	Felt, Flywheel
12-118	251324	Main Metal Case
12-119	253080	Main Metal

4. The symbol numbers shown on the P.C. Board list can be matched with the Composite Views of Components of the Schematic Diagram or Service Manual.
5. Please utilize separate "Common List for Service Parts" for Resistor Parts orders.
6. The shape of the parts and parts name, etc. can be confirmed by comparing them with the parts shown on the Electrical Parts Table of P.C. Board.
7. Both the kind of part and installation position can be determined by the Parts Number. To determine where a parts number is listed, utilize Parts Index at end of Parts List.  
It is necessary first of all to find the Parts Number. This can be accomplished by using the Reference Number listed at right of parts number in the Parts Index. (meaning of ref. no. outlined in Item 3 above).
8. Utilize separate "Price List for Parts" to determine unit price. The most simple method of finding parts Price is to utilize the reference number.

- CAUTION:**
1. When placing an order for parts, be sure to list the parts no. model no., and description. There are instances in which if any of this information is omitted, parts cannot be shipped or the wrong parts will be delivered.
  2. Please be careful not to make a mistake in the parts no. If the parts no. is in error, a part different from the one ordered may be delivered.
  3. Because parts number and parts unit supply in the Preliminary Service Manual (Basic Parts List) may be partially changed, please use this parts list for all future reference.

**WARNING:** ⚠ INDICATES SAFETY CRITICAL COMPONENTS. FOR CONTINUED SAFETY, REPLACE SAFETY CRITICAL COMPONENTS ONLY WITH MANUFACTURER'S RECOMMENDED PARTS.

**AVERTISSEMENT:** ⚠ IL INDIQU LES COMPOSANTS CRITIQUES DE SURETE. POUR MAINTENIR LE DEGRE DE SECURITE DE L'APPAREIL NE REMPLACER LES COMPOSANTS DONT LE FONCTIONNEMENT EST CRITIQUE POUR LA SECURITE QUE PAR DES PIECES RECOMMANDEES PAR LE FABRICANT.

## 1. RECOMMENDED SPARE PARTS

Because, if the parts listed below are on hand, almost any repair can be accomplished, we suggest that you stock these Recommended Spare Parts Items.

REF. NO.	PARTS NO.	DESCRIPTION	REF. NO.	PARTS NO.	DESCRIPTION
1-1	BHT2018A440A	HEAD BASE BLK GX-F95	1-59	EI322993	IC HD74107P
1-2	BKT2008A570A	OPERATION KEY ASSY GX-F90	1-60	EI306141	IC LA4170
1-3	BKT2008A570B	OPERATION KEY ASSY GX-F90-BL	1-61	EI325755	IC LC7550
1-4	BMM3101A020A	Δ MOTOR BLM-100B	1-62	EI306009	IC LM1111A
1-5	BM305728	Δ MOTOR GA608B01	1-63	EI300812	IC MB8841M (373M)
1-6	BMT2008A130A	Δ REEL MOTOR BLK W/PULLEY GX-F90	1-64	EI318922	IC MB8841M (424M)
1-7	BT201246	Δ TRANS POWER CU2T-1 (U,E,B,S)	1-65	EI213390	IC NJM4558D
1-8	BT201247	Δ TRANS POWER CU2T-2 (J)	1-66	EI304657	IC TC4011BP
1-9	BT201248	Δ TRANS POWER CU2T-4 (C,A)	1-67	EI302233	IC TC4051BP
1-10	EA307003	IND PC	1-68	EI200573	IC TC4053BP
1-11	EC315346	C S-FIX H ECV-1ZW50x32E 5.0-55	1-69	EI310036	IC TC4066BP
1-12	ED308953	D GERMA H 1K34A-LH SNP	1-70	EI300834	IC TC4520BP
1-13	ED308952	D GERMA V 1K34A-LR F07	1-71	EI317652	IC μPC629C
1-14	ED322247	D LED SLP-151D RED	1-72	EI319555	IC μPD4049C
1-15	ED322215	D LED SLP-251D GRN	1-73	EI201531	OSC X'TAL HC-18/U 6.022/30MHZ
1-16	ED200469	D SILICON H DS448 FA1 F10	1-74	EI318384	OSC X'TAL NC-18C 3.57954MHZ
1-17	ED316143	D SILICON H 1S2473HS F10	1-75	EI324061	PHOTO SENSOR NJL5146E
1-18	ED200468	D SILICON V DS448 VB3	1-76	EJ301513	Δ SOCKET INLET S-I6453 E 2P (U,E,B,S)
1-19	ED560913	D SILICON V 1S2473VE	1-77	EJ200618	SOCKET INLET HEC470-630
1-20	ED323979	D SILICON W03B F12 150/1.0A	1-78	EL317634	LAMP 5V 60MA
1-21	ED306109	D SILICON W03B 100/1.0A	1-79	EL317599	PL H LEAD 6.3V 100MA
1-22	ED322238	D SILICON 1B4B41 100/1.0A	1-80	EM317556	IND FL BG-49 GRAPH
1-23	ED322299	D SILICON 10D1FA-2 F12 100/1.0A	1-81	EM201809	IND LE SL-1405-20 CHARACTER
1-24	ED326496	D SILICON 3B4B41 100/3.0A	1-82	EP200835	Δ SOLENOID 0730PHT1
1-25	ED319463	D SILICON 4B4B41 100/4.0A	1-83	EP305795	Δ SOLENOID 1037THT1
1-26	ED313513	D THYRISTOR SF0R1B41 100V 0.10A	1-84	EP200836	Δ SOLENOID 1240PHT1
1-27	ED306983	D ZENER H HZ12 C3	1-85	EP308973	RELAY LEAD LAB2NS 2NO 24V
1-28	ED306320	D ZENER H HZ15 2	1-86	ER322265	Δ R CT P SNP 5W 130J
1-29	ED306015	D ZENER H HZ24 2	1-87	ER305791	Δ R FUSE FR25SJ 1/4J 100J
1-30	ED305704	D ZENER H HZ4 B2	1-88	ER308896	Δ R FUSE FR25SJ 1/4W 470J
1-31	ED302269	D ZENER H HZ5 A2	1-89	ER305772	Δ R FUSE FR25SJ 1/4W 6R8J
1-32	ED306316	D ZENER H HZ5 C2	1-90	ER313699	Δ R OMF H FS 2W 221J
1-33	ED306010	D ZENER H HZ6 A2	1-91	ER306006	Δ R OMF H FS 2W 222J
1-34	ED300035	D ZENER H HZ6 B3	1-92	ER328490	FILTER DB D07-001K 19KHZ
1-35	ED319167	D ZENER H HZ6 C3	1-93	ER328491	FILTER DB D07-003K 100KHZ
1-36	ED307610	D ZENER H HZ7 A2	1-94	ES305733	Δ SW SELECTOR HXW0131-260 01-4 (U,E,B,S)
1-37	ED306012	D ZENER H HZ7 A3	1-95	ES324063	SW LEAF BSW-47P 01-1 NO
1-38	ED305706	D ZENER H HZ7 B3	1-96	ES317622	SW LEAF BSW-47PB 01-1 NO
1-39	ED306013	D ZENER H HZ7 C1	1-97	ES305721	SW LEAF MSW-1145 01-1 NO
1-40	ED302295	D ZENER H HZ7 C3	1-98	ES201526	SW LEVER SLR522 2-02-02N
1-41	ED306014	D ZENER H HZ9 C3	1-99	ES201525	SW LEVER SLR523 2-02-03N
1-42	ED200620	THERMISTER TD5-C320D	1-100	ES315747	SW LEVER 42388 2-04-02N
1-43	ED305750	THERMISTER TD5-C350D	1-101	ES315748	SW LEVER 83157 2-08-03S
1-44	EF593706	Δ FUSE SEMKO T 250V 0.50A (U,E,B,S) (F1,2)	1-102	ES315159	SW PUSH SDG1P 01-1 J
1-45	EF623103	Δ FUSE SEMKO T 250V 1A (U,E,B,S) (F6)	1-103	ES310839	SW PUSH SDG1P-E 01-1 E
1-46	EF623125	Δ FUSE SEMKO T 250V 2.5A (U,E,B,S) (F3,4)	1-104	ES665875	SW PUSH SDG1P-J 01-1 UC
1-47	EF601301	Δ FUSE SEMKO T 250V 2A (U,E,B,S) (F5)	1-105	ES201527	SW SLIDE SSS212 1-01-02N
1-48	EF327103	Δ FUSE TSC A 250V 0.50A (J) (F1,2)	1-106	ES201548	SW SNAP SAC-22D 02-2
1-49	EF306951	Δ FUSE TSC A 250V 2.5A (J) (F3,4)	1-107	ET302405	TR FET 2SK150 GR
1-50	EF306950	Δ FUSE TSC A 250V 2A (J) (F5)	1-108	ET301464	TR FET 2SK68 M,N
1-51	EF309390	Δ FUSE TSC 125V 0.50V (C,A) (F1,2)	1-109	ET623790	TR 2SA640 E,F
1-52	EF306956	Δ FUSE TSC 125V 2.5A (C,A) (F3,4)	1-110	ET554657	TR 2SA733A P,Q
1-53	EF306954	Δ FUSE TSC 125V 2A (C,A) (F5)	1-111	ET302396	TR 2SA979 F,G
1-54	EI324668	D THYRISTOR AC03BGML 200V 3.00A	1-112	ET317688	TR 2SB564 K
1-55	EI325557	IC AP-400-A (TM4504P)	1-113	ET666415	TR 2SB605 K,L
1-56	EI302409	IC HD74LS02P	1-114	ET318125	TR 2SB743 P,Q
1-57	EI201549	IC HD7404P	1-115	ET308937	TR 2SC2130 G,H
1-58	EI201550	IC HD7407P	1-116	ET304825	TR 2SC2259 F,G
			1-117	ET200505	TR 2SC2603 E,F
			1-118	ET391768	TR 2SC458LG C,D
			1-119	ET316171	TR 2SC536K-NP E,F
			1-120	ET316643	TR 2SC536K-NP F,G
			1-121	ET399846	TR 2SC945L Q
			1-122	ET639437	TR 2SC945L Q,P
			1-123	ET302370	TR 2SD471 K,L
			1-124	ET666404	TR 2SD571 K,L
			1-125	ET307349	TR 2SD794 P,Q
			1-126	ET320296	TR 2SD837 P,Q

When ordering parts, please quote Parts Number, Description and Model Number.

REF. NO.	PARTS NO.	DESCRIPTION
1-127	ET200986	TR 2SD863-V8 F
1-128	EV315542	R S-FIX H D8 3P 103
1-129	EV315540	R S-FIX H D8 3P 502
1-130	EV315541	R S-FIX H D8 3P 503
1-131	EV306016	R S-FIX H TM8K (PV) 3P 0.30W 101
1-132	EV306007	R S-FIX H TM8K(PV) 3P 0.30W 203
1-133	EV464231	R S-FIX H V8K4-1 3P 104
1-134	EV464196	R S-FIX H V8K4-1 3P 202
1-135	EV522797	R S-FIX H V8K4-1 3P 203
1-136	EV523620	R S-FIX H V8K4-1 3P 501
1-137	EV464220	R S-FIX H V8K4-1 3P 503
1-138	EV572433	R S-FIX H V8K4-1 3P 504
1-139	EV325331	VR ROTARY 16P11x0Q A503 A503
1-140	EV319081	VR ROTARY 16P20x1Z B103
1-141	HE315742	HEAD E E-921-PQ-0201 C
1-142	HPH2402A010A	HEAD COMBO PR4-5 C
1-143	MB323686	DETECTION BELT
1-144	MI321191	IDLER ASSY
1-145	MPB319580	PINCH ROLLER PART GX-F90
1-146	MTB312122	REEL TABLE PART GXC-715D

## 2. HEAD BASE BLOCK

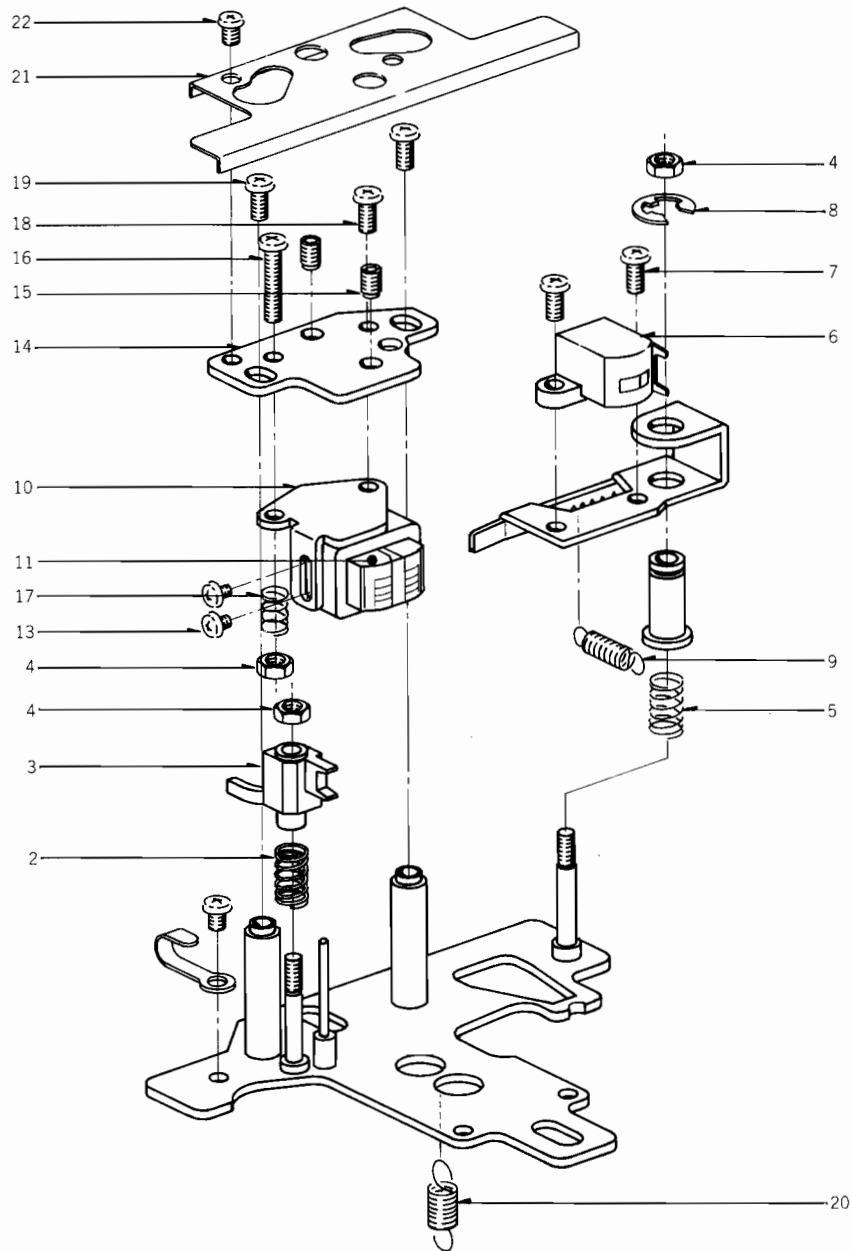

### HEAD BASE BLOCK

REF. NO.	PARTS NO.	DESCRIPTION	REF. NO.	PARTS NO.	DESCRIPTION
2-1x	BHT2018A440A	HEAD BASE BLK GX-F95	2-13	ZS300626	PAN20x2.5STL CMT CAMERA
2-2	ZG289236	TAPE GUIDE SPRING	2-14	HZ317355	HEAD HUNGER
2-3	HZ309128	TAPE GUIDE	2-15	ZS356804	6SET30x040SCM PKR HP
2-4	ZW591265	N23BRS NI3 3	2-16	ZS462947	PAN23x12STL CMT
2-5	ZG313187	SP C-4.5/0.5-8.0 C-034	2-17	ZG465636	ANGLE ADJUST SPRING
2-6	HE315742	HEAD E E-921-PQ-0201 C	2-18	ZS590804	PAN23x06STL CMT
2-7	ZS417227	BID23x05STL CMT	2-19	ZS419782	BID26x05STL CMT
2-8	ZW270123	RING E400SUP CMT	2-20	ZG312996	SP T1-4.0/0.4-14.0 T1-110
2-9	ZG312946	SP T1-3.2/0.29-16.0 T1-062			
2-10	HZ317352	HEAD HOLD PLATE	2-21	SZ317672	HEAD DECORATION PLATE
2-11	HPH2402A010A	HEAD COMBO PR4-5 C	2-22	ZS608174	PAN26x03STL NI3
2-12x	EA669510	PR4-1 TERMINAL P.C BOARD			

When ordering parts, please quote Parts Number, Description and Model Number.



### 3. SUB FRAME BLOCK

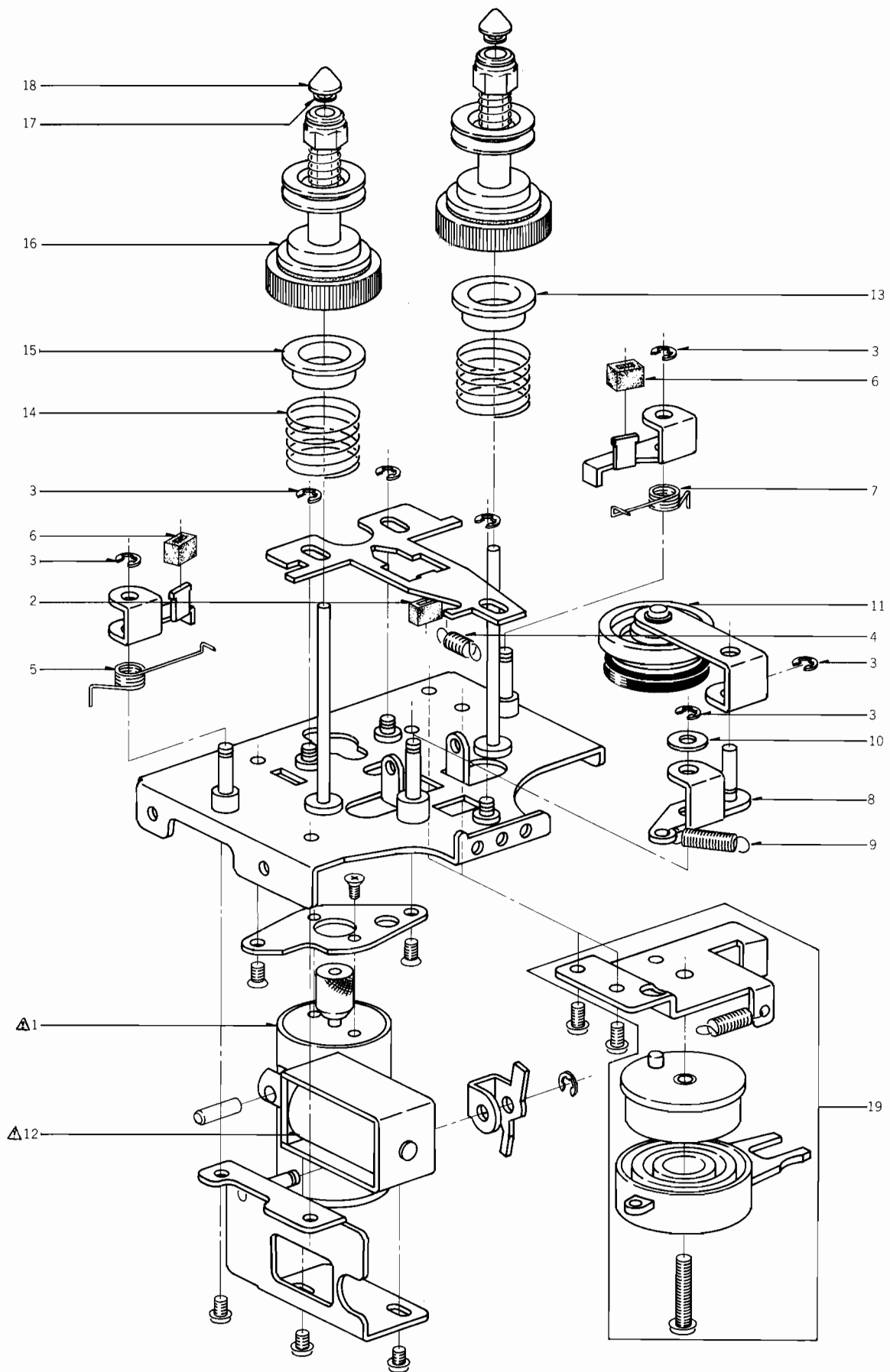

---

**SUB FRAME BLOCK**

REF. NO.	PARTS NO.	DESCRIPTION
<b>REEL MOTOR BLK</b>		
3-1	BMT2008A130A	△ REEL MOTOR BLK W/PULLEY GX-F90
<b>SUB FRAME BLK</b>		
3-2	TC328669	STOPPER RUBBER
3-3	ZW270088	RING E 190SUP CMT
3-4	ZG312943	SP T1-3.2/0.29-11.2 T1-059
3-5	ZG317429	BRAKE SPRING (L)
3-6	MB282104	BRAKE RUBBER
3-7	ZG317431	BRAKE SPRING (R)
3-8	MLB308406	IDLER LEVER PART GXC-715D
3-9	ZG321595	IDLER CLAMP SPRING
3-10	ZW432753	PW31x080x020PBR
3-11	MI321191	IDLER ASSY
3-12	EP200835	△ SOLENOID 0730PHT1
3-13	TC317433	TORQUE DRUM
3-14	ZG330077	SP BACK TENSION
3-15	TC318150	TORQUE DRUM (B)
3-16	MTB312122	REEL TABLE PART GXC-715D
3-17	ZS330073	PW21x040x020
3-18	MT305793	REEL CAP
3-19	TCT2018A040A	DAMPER (B) BLK GX-F95
3-20	ZS432843	PAN26x04STL CMT

## 4. MECHA BLOCK

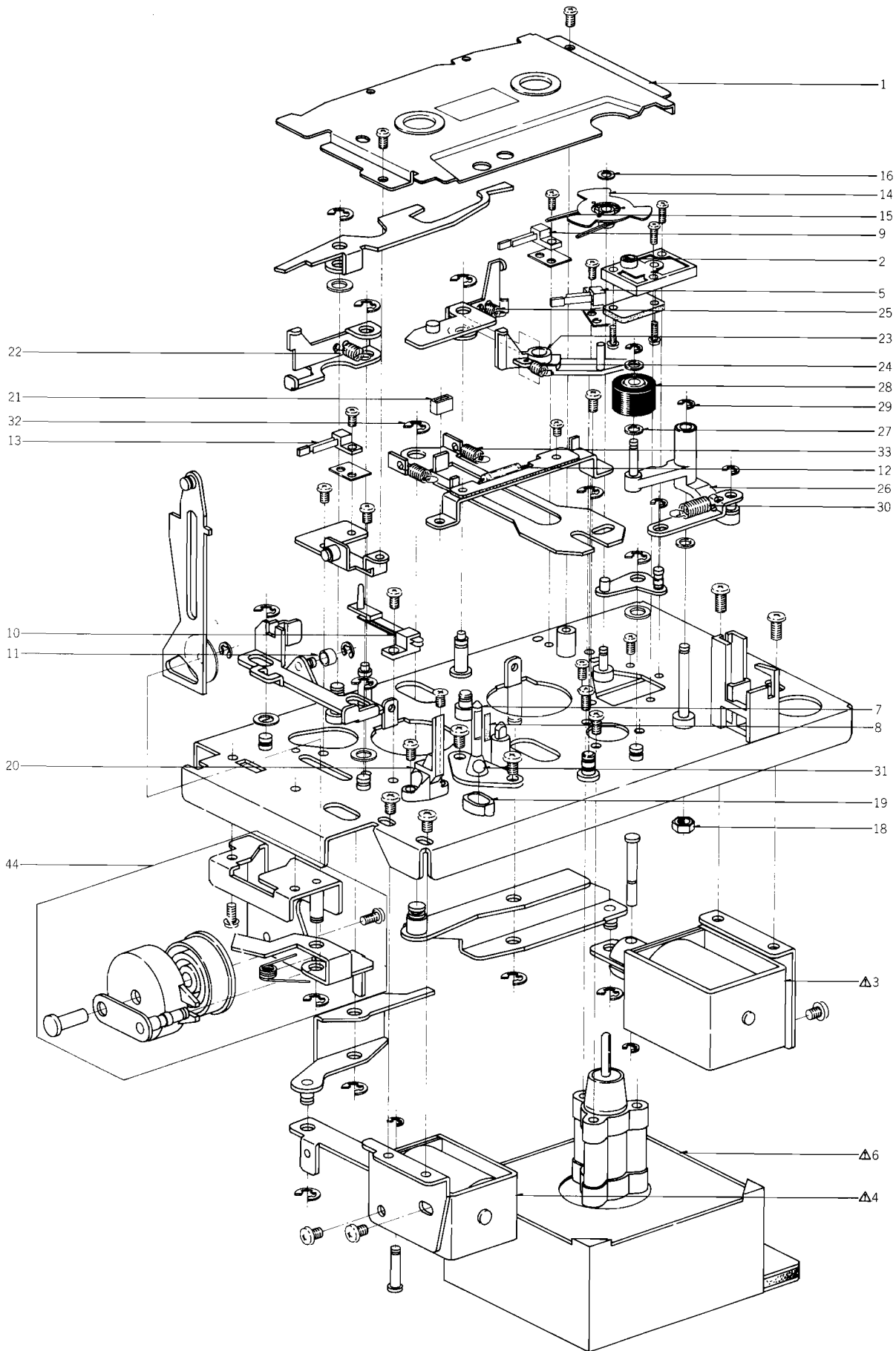

**MECHA BLOCK**

REF. NO.	PARTS NO.	DESCRIPTION
	<b>DECORATION PLAE BLK</b>	
4-1	BZT2018A420A	DECORATION PLATE BLK GX-F95
	<b>DETECTION PLATE BLK</b>	
4-2	EI324061	PHOTO SENSOR NJL5146E
	<b>PLAY PLUNGER BLK</b>	
4-3	EP200836	Δ SOLENOID 1240PHT1
	<b>PAUSE PLUNGER BLK</b>	
4-4	EP305795	Δ SOLENOID 1037THT1
	<b>REC DETECTION SW BLK</b>	
4-5	ES324063	SW LEAF BSW-47P 01-1 NO
	<b>MOTOR BLK</b>	
4-6	BMM3101A020A	Δ MOTOR BLM-100B
	<b>EH PAT BLK</b>	
4-7	TCT2018A080A	EH PAT BLK GX-F95
4-8	TC315648	PAD
	<b>CHROME DETECTION SW BLK</b>	
4-9	ES324063	SW LEAF BSW-47P 01-1 NO
	<b>METAL DETECTION SW BLK</b>	
4-10	ES317622	SW LEAF BSW-47PB 01-1 NO
	<b>LOCK SLIDE BLK</b>	
4-11	MR310663	ROLLER
	<b>HOUSING LAMP BLK</b>	
4-12	EL317599	PL H LEAD 6.3V 100MA
	<b>PACK DETECTION SW BLK</b>	
4-13	ES305721	SW LEAF MSW-1145 01-1 NO
	<b>MECHA BLK</b>	
4-14	MRB306596	DETECTION PULLEY PART GX-F95
4-15	MB323686	DETECTION BELT
4-16	ZW321437	PUSH WASHER
4-17x	ZW321703	LOCK PLATE WASHER
4-18	ZW273756	N30BRS 1
4-19	MS302191	BALL GUIDE
4-20	TC309145	CASSETTE GUIDE
4-21	MB282104	BRAKE RUBBER
4-22	ZG310531	SP T1-4.0/0.4-12.5 T1-109
4-23	ML306335	METAL DETECTION LEVER
4-24	ZG312943	SP T1-3.2/0.29-11.2 T1-059
4-25	ZG312942	SP T1-3.2/0.29-10.0 T1-058
4-26	MLB318775	PINCH ROLLER LEVER PART GX-F90
4-27	ZW259661	PW30x050x025PSL
4-28	MPB319580	PINCH ROLLER PART GX-F90
4-29	ZW270088	RING E 190SUP CMT
4-30	ZG317414	PINCH ROLLER SPRING
4-31	MV269965	BALL 400STL
4-32	ZW270101	RING E300SUP CMT
4-33	ZG317411	HEAD CLAMP SPRING
4-34	BZT2018A050A	EJECT DAMPER BLK GX-F95

## 5. EJECTOR BLOCK

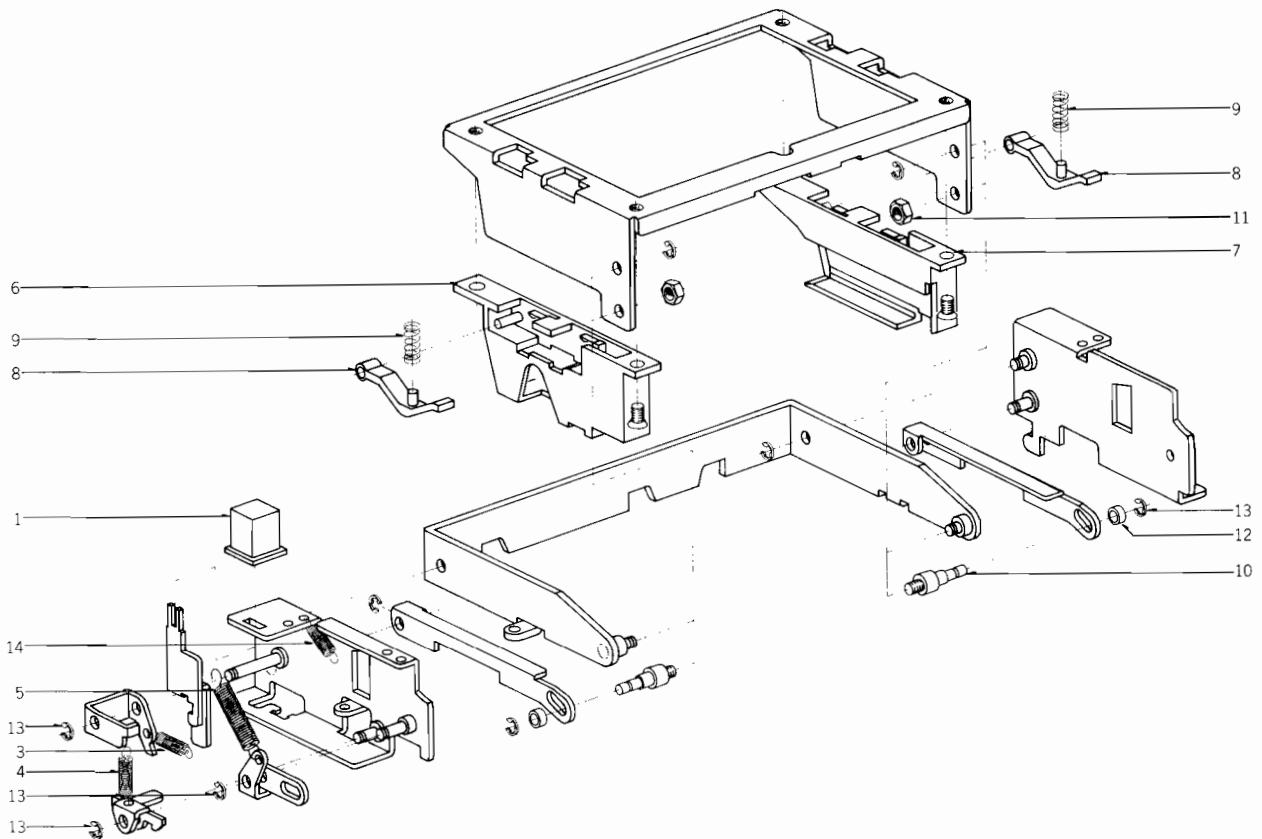

### EJECTOR BLOCK

REF. NO.	PARTS NO.	DESCRIPTION
5-1	SB316316	BUTTON (B)
5-2x	SB316317	BUTTON (B-BL)
5-3	ZG312944	SP T1-3.2/0.29-12.5 T1-060
5-4	ZG312926	SP T1-3.2/0.2-16.0 T1-043
5-5	ZG313003	SP T1-4.0/0.4-28.0 T1-116
5-6	TC317454	CASSETTE HOLDER (A)
5-7	TC317455	CASSETTE HOLDER (B)
5-8	TC309206	SETTING SHOE
5-9	ZG313165	SP C-3.5/0.32-10.0 C-013
5-10	MH306389	GUIDE PIN
5-11	ZW357658	N26BRS NI3 1
5-12	MR320323	LOCK ROLLER
5-13	ZW270088	RING E 190SUP CMT
5-14	ZG312943	SP T1-3.2/0.29-11.2 T1-059

When ordering parts, please quote Parts Number, Description and Model Number.

## 6. PRE AMP P.C BOARD BLOCK

REF. NO.	PARTS NO.	DESCRIPTION	REF. NO.	PARTS NO.	DESCRIPTION
6-1	BAT2018A160A	PRE AMP PC BLK GX-F95(U) (U,C,E,B,S)	6-SW1	ES315748	SW LEVER 83157 2-08-03S
6-2	BAT2018A160B	PRE AMP PC BLK GX-F95(J) (J,A)	6-SW2	ES315747	SW LEVER 42388 2-04-02N
6-IC1	EI306009	IC LM1111A	6-VR1,2	EV325331	VR ROTARY 16P11x0Q A503 A503
6-IC2,3	EI302233	IC TC4051BP	6-VR3	EV315542	R S-FIX H D8 3P 103
6-IC4	EI310036	IC TC4066BP	6-VR4to6	EV315541	R S-FIX H D8 3P 503
6-IC5	EI200573	IC TC4053BP	6-VR7,8	EV315542	R S-FIX H D8 3P 103
6-IC6	EI213390	IC NJM4558D	6-VR9	EV306016	R S-FIX H TM8K(PV) 3P 0.30W 101
6-IC7	EI306009	IC LM1111A	6-VR10	EV315541	R S-FIX H D8 3P 503
6-IC8	EI306141	IC LA4170	6-VR11	EV315540	R S-FIX H D8 3P 502
6-TR1	ET304825	TR 2SC2259 F,G	6-VR12	EV319081	VR ROTARY 16P20x1Z B103
6-TR2	ET623790	TR 2SA640 E,F	6-L1	EO669273	COIL FIX 2 FL5R200 18μH
6-TR3	ET391768	TR 2SC458LG C,D	6-RL1	EP308973	RELAY LEAD LAB2NS 2NO 24V
6-TR4	ET639437	TR 2SC945L Q,P	6-VL1	EO346230	COIL VARI 1 RX-22MH 22MH
6-TR5	ET554657	TR 2SA733A P,Q	6-T1,2	EO200622	COIL OSC1 2330-046 100KHZ
6-TR6	ET304825	TR 2SC2259 F,G	6-SCR1	ED313513	D THYRISTOR SF0R1B41 100V 0.10A
6-TR7	ET623790	TR 2SA640 E,F	6-FL1	ER328491	FILTER DB D07-003K 100KHZ
6-TR8	ET316171	TR 2SC536K-NP E,F	6-FL2	ER328490	FILTER DB D07-001K 19KHZ
6-TR9to11	ET554657	TR 2SA733A P,Q	6-FL3,4	EO315758	COIL TUN 1 100S-431 100KHZ
6-TR12	ET304825	TR 2SC2259 F,G	6-FL5	ER328491	FILTER DB D07-003K 100KHZ
6-TR13	ET623790	TR 2SA640 E,F	6-C1	EC323260	C EC V F05 NP LP 100M 16DC
6-TR14to19	ET316171	TR 2SC536K-NP E,F	6-C3	EC324376	C EC V F05 NP LR 1R0M 50DC
6-TR20to23	ET554657	TR 2SA733A P,Q	6-C6	EC323260	C EC V F05 NP LP 100M 16DC
6-TR24to26	ET316171	TR 2SC536K-NP E,F	6-C8	EC324376	C EC V F05 NP LR 1R0M 50DC
6-TR27	ET307349	Δ TR 2SD794 P,Q	6-C9	EC314991	C STY V F05 CQF09 221J 50DC
6-TR28,29	ET316171	TR 2SC536K-NP E,F	6-C29	EC314992	C STY V F05 CQF09 681J 50DC
6-TR30,31	ET200986	Δ TR 2SD863-V8 F	6-C31	EC314992	C STY V F05 CQF09 681J 50DC
6-TR32	ET304825	TR 2SC2259 F,G	6-C48	EC324402	C STY V SNP CQFS 102J 500DC
6-TR33	ET623790	TR 2SA640 E,F	6-C49	EC311435	C STY V SNP CQFS 152J 500DC
6-TR34	ET391768	TR 2SC458LG C,D	6-C50	EC324376	C EC V F05 NP LR 1R0M 50DC
6-TR35	ET639437	TR 2SC945L Q,P	6-C53	EC314995	C STY V F05 CQF09 331J 50DC
6-TR36	ET554657	TR 2SA733A P,Q	6-C57	EC306019	C STY V F05 CQ09S 911J 50DC
6-TR37to41	ET316171	TR 2SC536K-NP E,F	6-C59	EC302251	C STY V F05 CQF09 451J 50DC
6-TR42	ET307349	Δ TR 2SD794 P,Q	6-C61	EC314990	C STY V F05 CQF09 101J 50DC
6-TR43	ET316171	TR 2SC536K-NP E,F	6-C63	EC306022	C STY V F05 CQ09S 821J 50DC
6-TR44,45	ET200986	Δ TR 2SD863-V8 F	6-C64	EC324376	C EC V F05 NP LR 1R0M 50DC
6-TR46to49	ET639437	TR 2SC945L Q,P	6-C66	EC314991	C STY V F05 CQF09 221J 50DC
6-TR50	ET302405	TR FET 2SK150 GR	6-3	ZW263946	RV NYL40x050
6-TR51	ET391768	TR 2SC458LG C,D			
6-TR52	ET302396	TR 2SA979 F,G			
6-TR53	ET391768	TR 2SC458LG C,D			
6-TR54	ET639437	TR 2SC945L Q,P			
6-TR55	ET554657	TR 2SA733A P,Q			
6-TR56	ET639437	TR 2SC945L Q,P			
6-TR57	ET320296	Δ TR 2SD837 P,Q			
6-TR58	ET301464	TR FET 2SK68 M,N			
6-TR59	ET554657	TR 2SA733A P,Q			
6-TR60to63	ET316171	TR 2SC536K-NP E,F			
6-TR64,65	ET639437	TR 2SC945L Q,P			
6-TR66to68	ET316171	TR 2SC536K-NP E,F			
6-D2	ED308952	D GERMA V 1K34A-LR F07			
6-D3,4	ED200468	D SILICON V DS448 VB3			
6-D5,6	ED308952	D GERMA V 1K34A-LR F07			
6-D7	ED200468	D SILICON V DS448 VB3			
6-D8	ED560913	D SILICON V 1S2473VE			
6-D10	ED560913	D SILICON V 1S2473VE			
6-D11to17	ED200468	D SILICON V DS448 VB3			
6-D18	ED302269	D ZENER H HZ5 A2			
6-D20,21	ED200468	D SILICON V DS448 VB3			
6-D22	ED200469	D SILICON H DS448 FA1 F10			
6-D23,24	ED200468	D SILICON V DS448 VB3			
6-D25	ED306109	D SILICON W03B 100/1.0A			
6-D26to29	ED560913	D SILICON V 1S2473VE			
6-VC1,2	EC315346	C S-FIX H ECV-1ZW50x32E 5.0-55			
6-FR1,2	ER305772	Δ R FUSE FR25SJ 1/4W 6R8J			
6-FR3,4	ER305791	Δ R FUSE FR25SJ 1/4J 100J			
6-FR5to10	ER308896	Δ R FUSE FR25SJ 1/4W 470J			
6-J1	EJ302301	PHONE J HLJ0347-060 2x3P			
6-J2	EJ308986	PIN J 1784P1782 P 4P (U,C,E,B,S)			
6-J2	EJ308985	JACK PLATE DIN, PIN JACK 4P (J,A)			
6-J3	EJ325856	PHONE J 3P HLJ0317-020 6.3			

## 7. SYS. CON. P.C BOARD (CU-5214A) BLOCK

REF. NO.	PARTS NO.	DESCRIPTION
7-1	BAT2018A260A	SYSCON PC BLK GX-F95
7-IC1	EI300812	IC MB8841M (373M)
7-IC2,3	EI302409	IC HD74LS02P
7-IC4to6	EI201549	IC HD7404P
7-IC7	EI213390	IC NJM4558D
7-IC8	EI201550	IC HD7407P
7-TR1to7	ET639437	TR 2SC945L Q,P
7-TR8to12	ET554657	TR 2SA733A P,Q
7-TR13	ET639437	TR 2SC945L Q,P
7-TR14to23	ET554657	TR 2SA733A P,Q
7-TR24to27	ET639437	TR 2SC945L Q,P
7-TR28	ET554657	TR 2SA733A P,Q
7-TR29	ET639437	TR 2SC945L Q,P
7-TR30,31	ET317688	TR 2SB564 K
7-TR32to34	ET302370	TR 2SD471 K,L
7-TR35to37	ET639437	TR 2SC945L Q,P
7-TR38	ET666415	TR 2SB605 K,L
7-TR39	ET666404	TR 2SD571 K,L
7-TR40,41	ET308937	TR 2SC2130 G,H
7-TR42	ET666415	TR 2SB605 K,L
7-TR43	ET666404	TR 2SD571 K,L
7-TR44,45	ET308937	TR 2SC2130 G,H
7-TR46	ET666415	TR 2SB605 K,L
7-TR47	ET666404	TR 2SD571 K,L
7-TR48	ET308937	TR 2SC2130 G,H
7-TR49	ET639437	TR 2SC945L Q,P
7-TR50,51	ET554657	TR 2SA733A P,Q
7-TR52to65	ET639437	TR 2SC945L Q,P
7-TR66	ET316643	TR 2SC536K-NP F,G
7-TR74	ET393568	Δ TR 2SD234 Y,O 2-10-B
7-D1to6	ED316143	D SILICON H 1S2473HS F10
7-D8to13	ED316143	D SILICON H 1S2473HS F10
7-D14	ED302295	D ZENER H HZ7 C3
7-D15,16	ED316143	D SILICON H 1S2473HS F10
7-D17	ED323979	D SILICON W03B F12 150/1.0A
7-D18	ED322299	D SILICON 10D1FA-2 F12 100/1.0A
7-D19	ED316143	D SILICON H 1S2473HS F10
7-D20	ED323979	D SILICON W03B F12 150/1.0A
7-D21	ED322299	D SILICON 10D1FA-2 F12 100/1.0A
7-D22	ED316143	D SILICON H 1S2473HS F10
7-D23,24	ED322299	D SILICON 10D1FA-2 F12 100/1.0A
7-D25to30	ED316143	D SILICON H 1S2473HS F10
7-D31	ED308953	D GERMA H 1K34A-LH SNP
7-D32	ED316143	D SILICON H 1S2473HS F10
7-D33to36	ED200469	D SILICON H DS448 FA1 F10
7-J1	EJ324276	DIN J TCS4680-01-111 P 8P
7-J2	EJ200618	SOCKET INLET HEC470-630
7-SW1,2	ES201525	SW LEVER SLR523 2-02-03W
7-SW3,4	ES201526	SW LEVER SLR522 2-02-02N
7-VR1	EV523620	R S-FIX H V8K4-1 3P 501
7-R80	ER322265	Δ R CT P SNP SW 130J

## 8. AUTO TUNING P.C BOARD BLOCK

REF. NO.	PARTS NO.	DESCRIPTION
8-1	BAT2018A290A	AUTOTUNING PC BLK GX-F95
8-IC1	EI318922	IC MB8841M (424M)
8-IC2	EI213390	IC NJM4558D
8-IC3,4	EI302409	IC HD74LS02P
8-IC5,6	EI300834	IC TC4520BP
8-IC7	EI317652	IC μPC629C
8-IC8	EI310036	IC TC4066BP
8-IC9	EI322993	IC HD74107P
8-IC10	EI302409	IC HD74LS02P
8-IC11	EI319555	IC μPD4049C
8-IC12,13	EI213390	IC NJM4558D
8-IC14,15	EI302233	IC TC4051BP
8-IC16	EI200573	IC TC4053BP
8-TR1to11	ET639437	TR 2SC945L Q,P
8-TR12to15	ET554657	TR 2SA733A P,Q
8-TR16to22	ET639437	TR 2SC945L Q,P
8-TR23to33	ET554657	TR 2SA733A P,Q
8-TR34to37	ET639437	TR 2SC945L Q,P
8-TR38,39	ET554657	TR 2SA733A P,Q
8-TR40to45	ET639437	TR 2SC945L Q,P
8-TR46	ET307349	Δ TR 2SD794 P,Q
8-TR47	ET320296	Δ TR 2SD837 P,Q
8-TR48	ET639437	TR 2SC945L Q,P
8-TR49	ET554657	TR 2SA733A P,Q
8-D1,2	ED308952	D GERMA V 1K34A-LR F07
8-D3	ED305704	D ZENER H HZ4 B2
8-D4to9	ED316143	D SILICON H 1S2473HS F10
8-D10	ED323979	D SILICON W03B F12 150/1.0A
8-D11to18	ED316143	D SILICON H 1S2473HS F10
8-D19	ED305706	D ZENER H HZ7 B3
8-D20	ED323979	D SILICON W03B F12 150/1.0A
8-D21,22	ED316143	D SILICON H 1S2473HS F10
8-D23	ED307610	D ZENER H HZ7 A2
8-D24	ED323979	D SILICON W03B F12 150/1.0A
8-D25,26	ED316143	D SILICON H 1S2473HS F10
8-D27	ED323979	D SILICON W03B F12 150/1.0A
8-SW1	ES201527	SW SLIDE SSS212 1-01-02N
8-VR1	EV464196	R S-FIX H V8K4-1 3P 202
8-VR2	EV522797	R S-FIX H V8K4-1 3P 203
8-VR3	EV464220	R S-FIX H V8K4-1 3P 503
8-VR4,5	EV464231	R S-FIX H V8K4-1 3P 104
8-VR6	EV572433	R S-FIX H V8K4-1 3P 504
8-VR7	EV464231	R S-FIX H V8K4-1 3P 104
8-VR8	EV572433	R S-FIX H V8K4-1 3P 504
8-VR9	EV522797	R S-FIX H V8K4-1 3P 203
8-X1	EI318384	OSC X'TAL NC-18C 3.579545MHZ
8-TH1	ED305750	THERMISTER TD5-C350D
8-TH2,3	ED200620	THERMISTER TD5-C320D
8-C30	EC324921	C STY V F05 CQ09S 101J 50DC
8-C49	EC315967	C EC V CUT SM 332M 16DC
8-2	TC302235	P.C BOARD HINGE

When ordering parts, please quote Parts Number, Description and Model Number.

### 9. POWER SUPPLY P.C BOARD BLOCK

REF. NO.	PARTS NO.	DESCRIPTION
9-1	BAT2018A210A	POWER PC BLK GX-F95(U) (U,E,B,S)
9-2	BAT2018A210B	POWER PC BLK GX-F95(J)
9-3	BAT2018A210C	POWER PC BLK GX-F95(C) (C,A)
9-IC1	EI325557	IC AP-400-A (TM4504P)
9-IC2	EI304657	IC TC4011BP
9-TR1	ET666404	Δ TR 2SD571 K,L
9-TR2,3	ET639437	TR 2SC945L Q,P
9-TR4,5	ET554657	TR 2SA733A P,Q
9-TR6	ET666415	Δ TR 2SB605 K,L
9-TR7	ET639437	Δ TR 2SC945L Q,P
9-TR8	ET554657	TR 2SA733A P,Q
9-TR9	ET639437	TR 2SC945L Q,P
9-TR10	ET320296	Δ TR 2SD837 P,Q
9-TR11to15	ET320296	Δ TR 2SD837 P,Q
9-TR16	ET399846	TR 2SC945L Q
9-TR17	ET307349	TR 2SD794 P,Q
9-TR18	ET639437	TR 2SC945L Q,P
9-TR19	ET318125	Δ TR 2SB743 P,Q
9-TR20	ET200505	Δ TR 2SC2603 E,F
9-TR21	ET666415	Δ TR 2SB605 K,L
9-D1	ED322238	Δ D SILICON 1B4B41 100/1.0A
9-D2,3	ED306012	D ZENER H HZ7 A3
9-D4	ED306010	D ZENER H HZ6 A2
9-D5	ED306013	D ZENER H HZ7 C1
9-D6	ED300035	D ZENER H HZ6 B3
9-D7	ED560913	D SILICON V 1S2473VE
9-D8	ED326496	Δ D SILICON 3B4B41 100/3.0A
9-D9	ED306983	D ZENER H HZ12 C3
9-D10	ED306015	D ZENER H HZ24 2
9-D11	ED319463	Δ D SILICON 4B4B41 100/4.0A
9-DD12,13	ED306109	Δ D SILICON W03B 100/1.0A
9-D14	ED319167	D ZENER H HZ6 C3
9-D16to18	ED560913	D SILICON V 1S2473VE
9-D19	ED306316	D ZENER H HZ5 C2
9-D20,21	ED200468	Δ D SILICON V DS448 VB3
9-D22	ED306320	D ZENER H HZ15 2
9-D23	ED306014	D ZENER H HZ9 C3
9-VR1	EV315540	R S-FIX H D8 3P 502
9-VR2	EV306007	R S-FIX H TM8K(PV) 3P 0.30W 203
9-X1	EI201531	OSC X'TAL HC-18/U 6.022/30MHZ
9-SW1	ES310839	Δ SW PUSH SDG1P-E 01-1 E (U,E,B,S)
9-SW1	ES315159	Δ SW PUSH SDG1P 01-1 J (J)
9-SW1	ES665875	Δ SW PUSH SDG1P-J 01-1 UC (C,A)
9-R20	ER306006	Δ R OMF H FS 2W 222J
9-R38	ER313699	Δ R OMF H FS 2W 221J
9-C14	EC306321	C EC V SNP NM 472 50DC
9-C15	EC322420	C EC V CUT SM 332M 25DC
9-C21	EC322804	C EC V CUT SM 472M 16DC
9-C27	EC327382	Δ C MP V 472M 250AC (U,E,B,S)
9-C27	EC320548	Δ C CE V F 103Z 250AC (J)
9-C27	EC314688	Δ C CE V FZ 103P 125AC(C,A)

### 10. BAR METER P.C BOARD BLOCK

REF. NO.	PARTS NO.	DESCRIPTION
10-1	EA307003	IND PC
10-IC1	EI325755	IC LC7550
10-D1to16	ED322215	D LED SLP-251D GRM
10-D17to21	ED322247	D LED SLP-151D RED
10-IN1	EM317556	IND FL BG-49 GRAPH

NOTE: Should be order as a pair EA-307003 (IND PC) and EI-325755 (IC LC7550).

### 11. COUNTER P.C BOARD BLOCK

REF. NO.	PARTS NO.	DESCRIPTION
11-IN1	EM201809	IND LE SL-1405-20 CHARACTER

### 12. INTEGRAL P.C BOARD BLOCK

REF. NO.	PARTS NO.	DESCRIPTION
12-TR1,2	ET316171	TR 2SC536K-NP E,F
12-D1	ED560913	D SILICON V 1S2473VE

### 13. MOTOR P.C BOARD BLOCK

REF. NO.	PARTS NO.	DESCRIPTION
13-1	BAT2008A090A	MOTOR PC BLK GX-F90

### 14. DOOR OPEN P.C BOARD BLOCK

REF. NO.	PARTS NO.	DESCRIPTION
14-D1	EI324668	D THYRISTOR AC03BGML 200V 3.00A
14-D2	ED322299	D SILICON 10D1FA-2 F12 100/1.0A
14-SW1	ES201548	SW SNAP SAC-22D 02-2
14-L1	EO669273	COIL FIX 2 FL5R200 18μH



15. ASSEMBLY BLOCK (1)

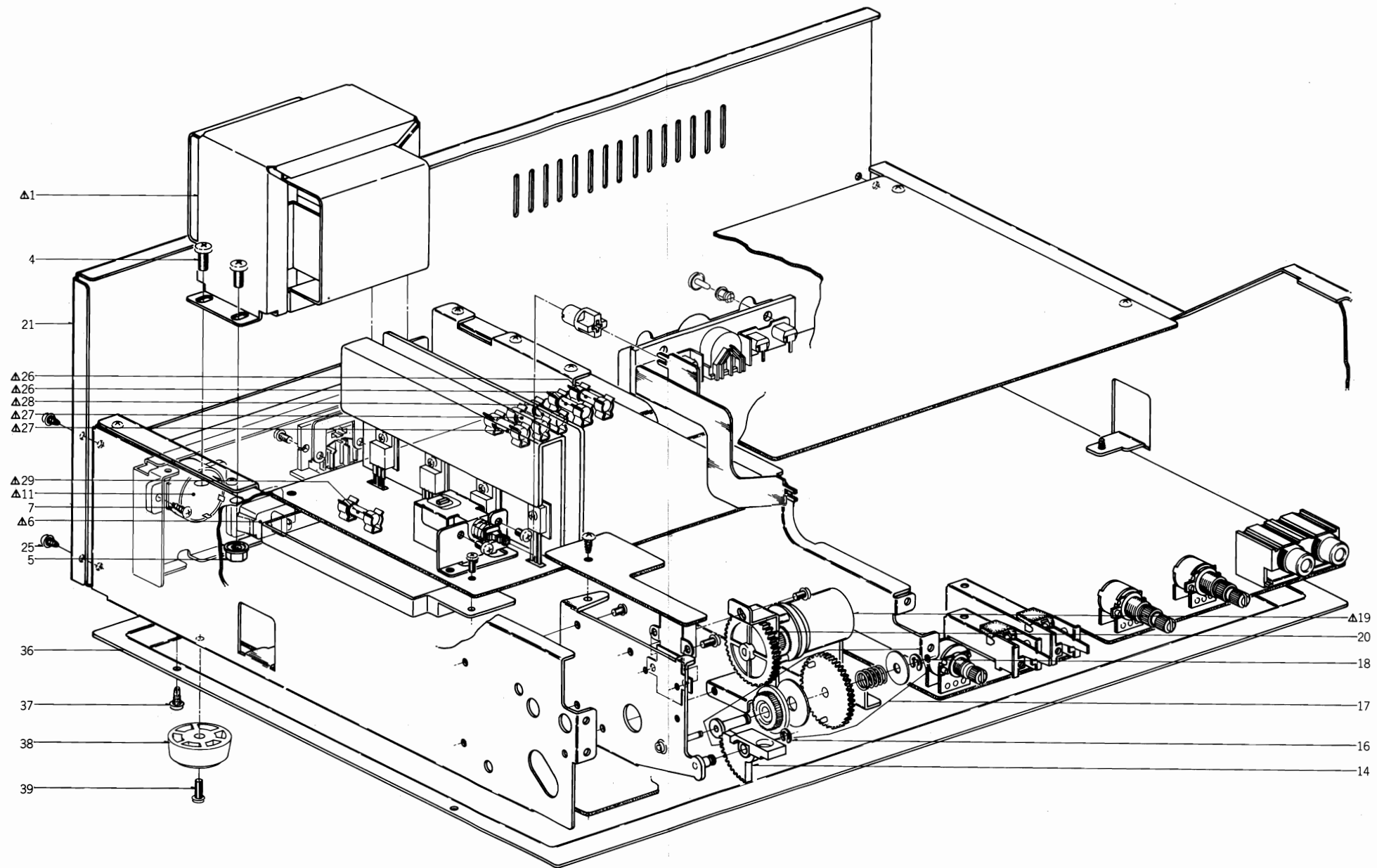

**ASSEMBLY BLOCK (1)**

REF. NO.	PARTS NO.	DESCRIPTION	REF. NO.	PARTS NO.	DESCRIPTION	REF. NO.	PARTS NO.	DESCRIPTION	REF. NO.	PARTS NO.	DESCRIPTION
	<b>TRANS BASE BLK</b>										
15-1	BT201246	Δ TRANS POWER CU2T-1 (U,E,B,S)	15-12x	EZ329981	VOLTAGE SELECTOR COVER (E,B,S)	15-24x	SP306559C	REAR PANEL GX-F95(A)	15-34x	EF306956	Δ FUSE TSC 125V 2.5A (C,A) (F3,4)
15-2x	BT201247	Δ TRANS POWER CU2T-2 (J)	15-13x	TA328841	COVER 2P INLET (U,E,B,S)	15-25	ZS447761	T2BR30x06STL BNI	15-35x	EF306954	Δ FUSE TSC 125V 2A (C,A) (F5)
15-3x	BT201248	Δ TRANS POWER CU2T-4 (C,A)		<b>DOOR OPEN BLK</b>		15-26	EF593706	Δ FUSE SEMKO T 250V 0.50A (U,E,B,S) (F1,2)	15-36	SP306544	BOTTOM COVER
15-4	ZS416687	BID40x08STL CMT	15-14	TC306395A	DOOR HINGE	15-27	EF623125	Δ FUSE SEMKO T 250V 2.5A (U,E,B,S) (F3,4)	15-37	ZS325495	T2BR30x06STL CMT
15-5	ZW413267	N FRANGE 40STL CMT	15-15x	TC306395B	DOOR HINGE (BL)	15-28	EF601301	Δ FUSE SEMKO T 250V 2A (U,E,B,S) (F5)	15-38	SA311742	ROUND FOOT
15-6	EJ301513	Δ SOCKET INLET S-16453 E 2P (U,E,B,S)	15-16	ZW357164	RING E230SUP CMT	15-29	EF623103	Δ FUSE SEMKO T 250V 1A (U,E,B,S) (F6)	15-39	ZS306463	ST PAN30x08STL CMT C
15-7	ZS325495	T2BR30x06STL CMT (U,E,B,S)	15-17	TCT2018A370A	MIDDLE GEAR BLK GX-F95	15-30x	EF327103	Δ FUSE TSC A 250V 0.50A (J) (F1,2)	15-40x	EW306152	Δ AC CORD 2 CORES KP-205A/KS-15 UCJ (U)
15-8x	EW306427	Δ AC CORD 2 CORES KP-211, VFF J (J)	15-18	ZW391397	RING E120SUP CMT	15-31x	EF306951	Δ FUSE TSC A 250V 2.5A (J) (F3,4)	15-41x	EW315767	Δ AC CORD 2 CORES KP-419C/KS-15 E (E)
15-9x	EW328245	Δ AC CORD 2 CORES KP-8/SPT-1 105C UC (C,A)	15-19	BM305728	Δ MOTOR GA608B01	15-32x	EF306950	Δ FUSE TSC A 250V 2A (J) (F5)	15-42x	EW322400	Δ AC CORD 2 CORES GTBS-2F/KS-15 B (B)
15-10x	SZ631945	STRAIN RELIEF SR-4N-4 (J,C,A)	15-20	MR306397	MIDDLE GEAR (A)	15-33x	EF309390	Δ FUSE TSC 125V 0.50V (C,A) (F1,2)	15-43x	EW322401	Δ AC CORD 2 CORES KP-560/S-15 S (S)
15-11	ES305733	Δ SW SELECTOR HXW0131-260 01-4 (U,E,B,S)		<b>ASSEMBLY BLK</b>							
			15-21	SP306559D	REAR PANEL GX-F95 (U,E,B,S)						
			15-22x	SP306559A	REAR PANEL GX-F95(J)						
			15-23x	SP306559B	REAR PANEL GX-F95(C)						

When ordering parts, please quote Parts Number, Description and Model Number.

16. ASSEMBLY BLOCK (2)

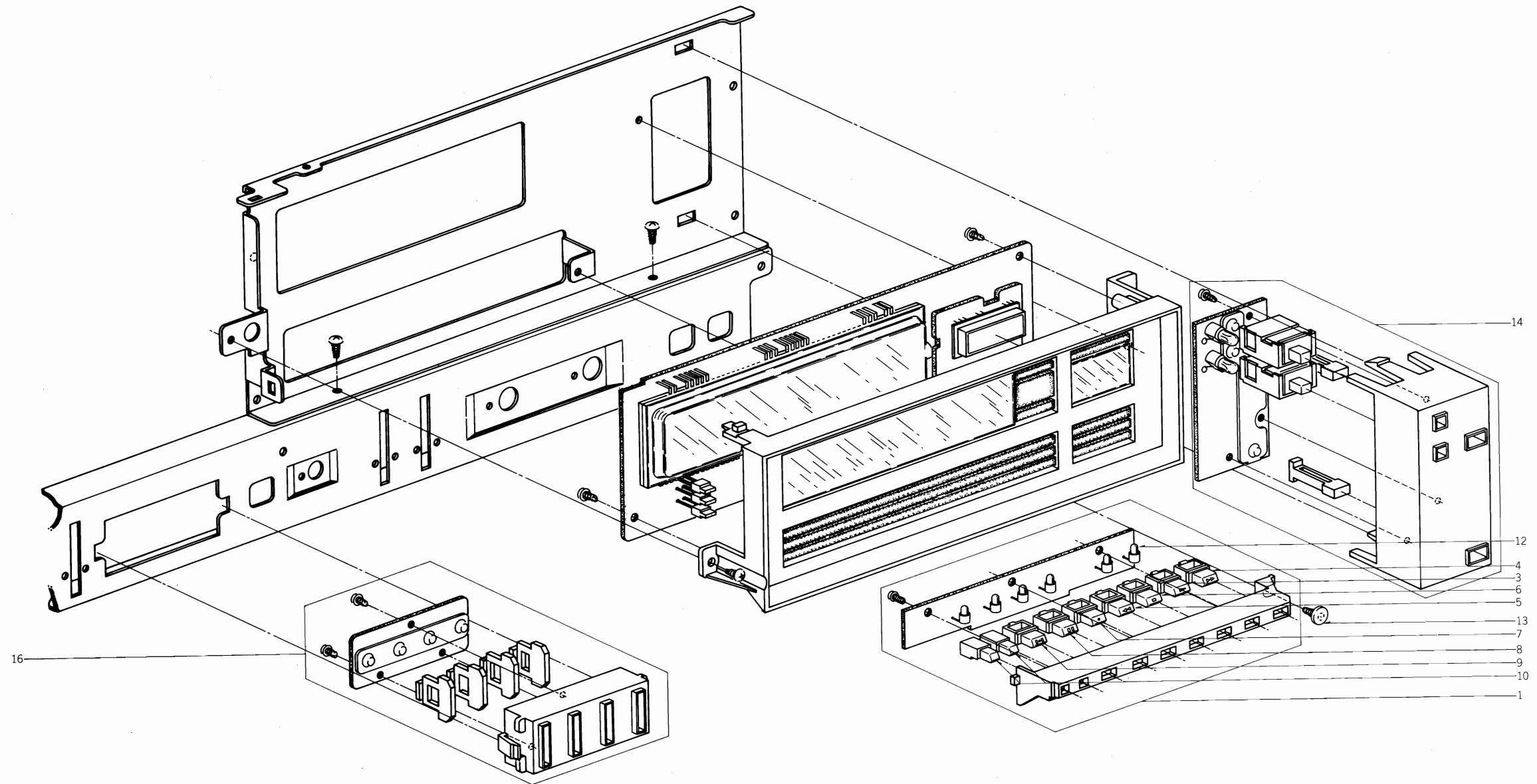

**ASSEMBLY BLOCK (2)**

REF. NO.	PARTS NO.	DESCRIPTION	REF. NO.	PARTS NO.	DESCRIPTION
16-1	BKT2008A570A	OPERATION KEY ASSY GX-F90	16-11x	SB317642	OPERATION BUTTON (BL)
16-2x	BKT2008A570B	OPERATION KEY ASSY GX-F90-BL	16-12	EL317634	LAMP 5V 60MA
16-3	SB317625	OPERATION BUTTON (PB)	16-13	ZS317554	TAP-TIGHT SCREW, GRADUATED
16-4	SB317626	OPERATION BUTTON (FF)			3x5
16-5	SB317627	OPERATION BUTTON (REW)	16-14	ES305734	SW OPERATION J-P5425#01 4P
16-6	SB317628	OPERATION BUTTON (STOP)	16-15x	ES305936	SW OPERATION J-P5425#02 4P
16-7	SB317629	OPERATION BUTTON (REC)	16-16	ES305735	SW OPERATION J-P5424#01 4P
16-8	SB317630	OPERATION BUTTON (PAUSE)	16-17x	ES305963	SW OPERATION J-P5424#02 4P
16-9	SB317631	OPERATION BUTTON (REC MUTE)	16-18x	ZW241200	RV NYL30x080 BL
16-10	SB317633	OPERATION BUTTON			

When ordering parts, please quote Parts Number, Description and Model Number.

## 17. FINAL ASSEMBLY BLOCK

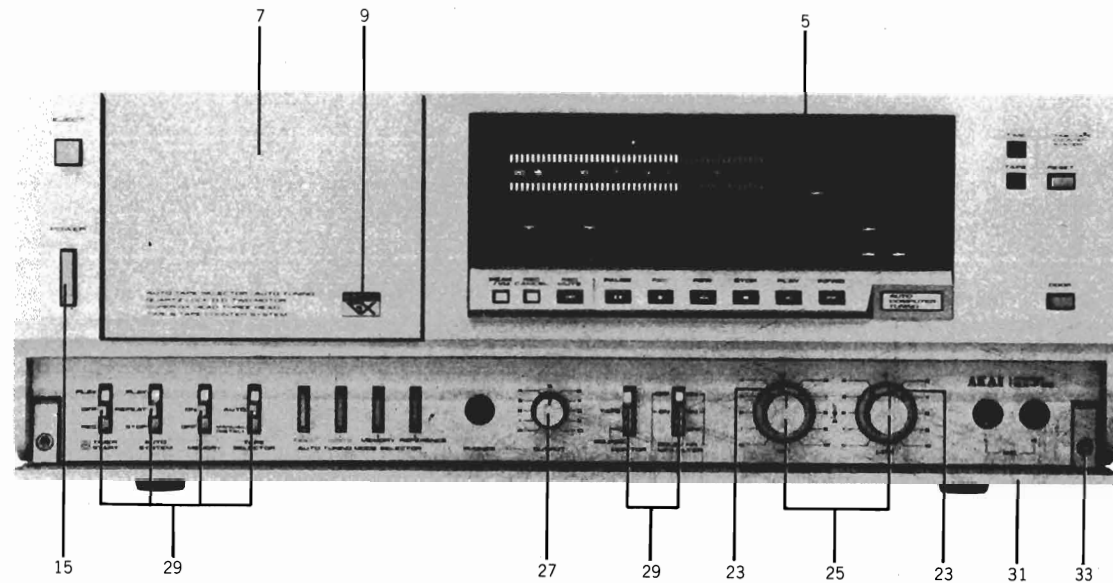

### FINAL ASSEMBLY BLOCK

REF. NO.	PARTS NO.	DESCRIPTION
<b>FRONT PANEL BLK</b>		
17-1	BDT2018A390A	FRONT PANEL BLK GX-F95(U) (U,C,E,B,S)
17-2x	BDT2018A390B	FRONT PANEL BLK GX-F95(J)(J,A)
17-3x	BDT2018A390C	FRONT PANEL BLK GX-F95-BL(U) (U,C,E,B,S)
17-4x	BDT2018A390D	FRONT PANEL BLK GX-F95-BL(J) (J,A)
17-5	SZ306578	METER WINDOW
<b>LID PANEL (A) BLK</b>		
17-6x	IC306545A	LID HOLD PLATE (A)
17-7	SP306400A	LID PANEL (A)
17-8x	SP306400B	LID PANEL (A)-BL
17-9	SM315737	SUPER GX NAME PLATE
<b>LID PANEL (B) BLK</b>		
17-10x	TC306545B	LID HOLD PLATE (B)
17-11x	TC306591	LID GLASS
17-12x	ZS315686	DECORATION SCREW (BL)
<b>HINGE PANEL BLK</b>		
17-13x	TC306395A	DOOR HINGE
17-14x	TC306395B	DOOR HINGE (BL)

REF. NO.	PARTS NO.	DESCRIPTION
<b>FINAL ASSEMBLY BLK</b>		
17-15	SB315697	BUTTON (B)
17-16x	SB315698	BUTTON (B-BL)
17-17x	SP306540A	UPPER COVER
17-18x	SP306540B	UPPER COVER (BL)
17-19x	SP306540C	UPPER COVER (AAL)
17-20x	ZS315878	XST BID40x08STL NI3
17-21x	ZS310588	XST BID40x08STL BNI (A,BL)
17-22x	ZS447761	T2BR30x06STL BNI
17-23	SK329031	DOUBLE KNOB (LOWER-A)
17-24x	SK329030	DOUBLE KNOB (LOWER-BL)
17-25	SK306765	DOUBLE KNOB (UPPER-B)
17-26x	SK306771	DOUBLE KNOB (UPPER-B)-BL
17-27	SK306935	KNOB (F)
17-28x	SK306964	KNOB (F)-BL
17-29	SK306902	LEVER KNOB (B)
17-30x	SK329034	LEVER KNOB (BL)
17-31	BZB306547A	DOOR PART GX-F95
17-32x	BZB306547B	DOOR PART GX-F95-BL
17-33	ZS613901	PANEL SCREW
17-34x	ZS306435	PANEL SCREW (C) (BL)
17-35x	ZW305013	RV POP32

PARTS NO.	REF. NO.	PARTS NO.	REF. NO.	PARTS NO.	REF. NO.	PARTS NO.	REF. NO.
BAT2008A090A	13-1	ED308952	6-D5,6	EJ302301	6-J1	ET391768	6-TR34
BAT2018A160A	6-1	ED308952	8-D1,2	EJ308985	6-J2	ET391768	6-TR51
BAT2018A160B	6-2	ED308953	7-D31	EJ308986	6-J2	ET391768	6-TR53
BAT2018A210A	9-1	ED313513	6-SCR1	EJ324276	7-J1	ET393568	7-TR74
BAT2018A210B	9-2	ED316143	7-D1to6	EJ325856	6-J3	ET399846	9-TR16
BAT2018A210C	9-3	ED316143	7-D8to13	EL317599	4-12	ET554657	6-TR5
BAT2018A260A	7-1	ED316143	7-D15,16	EL317634	16-12	ET554657	6-TR9to11
BAT2018A290A	8-1	ED316143	7-D19	EM201809	11-IN1	ET554657	6-TR20to23
BDT2018A390A	17-1	ED316143	7-D22	EM317556	10-IN1	ET554657	6-TR36
BDT2018A390B	17-2x	ED316143	7-D25to30	EO200622	6-T1,2	ET554657	6-TR55
BDT2018A390C	17-3x	ED316143	7-D32	EO315758	6-FL3,4	ET554657	6-TR59
BDT2018A390D	17-4x	ED316143	8-D4to9	EO346230	6-VL1	ET554657	7-TR8to12
BHT2018A440A	2-1x	ED316143	8-D11to18	EO669273	6-L1	ET554657	7-TR14to23
BKT2008A570A	16-1	ED316143	8-D21,22	EO669273	14-L1	ET554657	7-TR28
BKT2008A570B	16-2x	ED316143	8-D25,26	EP200835	3-12	ET554657	7-TR50,51
BMM3101A020A	4-6	ED319167	9-D14	EP200836	4-3	ET554657	8-TR12to15
BMT2008A130A	3-1	ED319463	9-D11	EP305795	4-4	ET554657	8-TR23to33
BM305728	15-19	ED322215	10-D1to16	EP308973	6-RL1	ET554657	8-TR38,39
BT201246	15-1	ED322238	9-D1	ER305772	6-FR1,2	ET554657	8-TR49
BT201247	15-2x	ED322247	10-D17to21	ER305791	6-FR3,4	ET554657	9-TR4,5
BT201248	15-3x	ED322299	7-D18	ER306006	9-R20	ET554657	9-TR8
BZB306547A	17-31	ED322299	7-D21	ER308896	6-FR5to10	ET623790	6-TR2
BZB306547B	17-32x	ED322299	7-D23,24	ER313699	9-R38	ET623790	6-TR7
BZT2018A050A	4-34	ED322299	14-D2	ER322265	7-R80	ET623790	6-TR13
BZT2018A420A	4-1	ED323979	7-D17	ER328490	6-FL2	ET623790	6-TR33
EA307003	10-1	ED323979	7-D20	ER328491	6-FL1	ET639437	6-TR4
EA669510	2-12x	ED323979	8-D10	ER328491	6-FL5	ET639437	6-TR35
EC302251	6-C59	ED323979	8-D20	ES201525	7-SW1,2	ET639437	6-TR46to49
EC306019	6-C57	ED323979	8-D24	ES201526	7-SW3,4	ET639437	6-TR54
EC306022	6-C63	ED323979	8-D27	ES201527	8-SW1	ET639437	6-TR56
EC306321	9-C14	ED326496	9-D8	ES201548	14-SW1	ET639437	6-TR64,65
EC311435	6-C49	ED560913	6-D8	ES305721	4-13	ET639437	7-TR1to7
EC314688	9-C27	ED560913	6-D10	ES305733	15-11	ET639437	7-TR13
EC314990	6-C61	ED560913	6-D26to29	ES305734	16-14	ET639437	7-TR24to27
EC314991	6-C9	ED560913	9-D7	ES305735	16-16	ET639437	7-TR29
EC314991	6-C66	ED560913	9-D16to18	ES305936	16-15x	ET639437	7-TR35to37
EC314992	6-C29	ED560913	12-D1	ES305963	16-17x	ET639437	7-TR49
EC314992	6-C31	EF306950	15-32x	ES310839	9-SW1	ET639437	7-TR52to65
EC314995	6-C53	EF306951	15-31x	ES315159	9-SW1	ET639437	8-TR1to11
EC315346	6-VC1,2	EF306954	15-35x	ES315747	6-SW2	ET639437	8-TR16to22
EC315967	8-C49	EF306956	15-34x	ES315748	6-SW1	ET639437	8-TR34to37
EC320548	9-C27	EF309390	15-33x	ES317622	4-10	ET639437	8-TR40to45
EC322420	9-C15	EF327103	15-30x	ES324063	4-5	ET639437	8-TR48
EC322804	9-C21	EF593706	15-26	ES324063	4-9	ET639437	9-TR2,3
EC323260	6-C1	EF601301	15-28	ES665875	9-SW1	ET639437	9-TR7
EC323260	6-C6	EF623103	15-29	ET200505	9-TR20	ET639437	9-TR9
EC324376	6-C3	EF623125	15-27	ET200986	6-TR30,31	ET639437	9-TR18
EC324376	6-C8	EI200573	6-IC5	ET200986	6-TR44,45	ET666404	7-TR39
EC324376	6-C50	EI200573	8-IC16	ET301464	6-TR58	ET666404	7-TR43
EC324376	6-C64	EI201531	9-X1	ET302370	7-TR32to34	ET666404	7-TR47
EC324402	6-C48	EI201549	7-IC4to6	ET302396	6-TR52	ET666404	9-TR1
EC324921	8-C30	EI201550	7-IC8	ET302405	6-TR50	ET666415	7-TR38
EC327382	9-C27	EI213390	6-IC6	ET304825	6-TR1	ET666415	7-TR42
ED200468	6-D3,4	EI213390	7-IC7	ET304825	6-TR6	ET666415	7-TR46
ED200468	6-D7	EI213390	8-IC2	ET304825	6-TR12	ET666415	9-TR6
ED200468	6-D11to17	EI213390	8-IC12,13	ET304825	6-TR32	ET666415	9-TR21
ED200468	6-D20,21	EI300812	7-IC1	ET307349	6-TR27	EV306007	6-VR2
ED200468	6-D23,24	EI300834	8-IC5,6	ET307349	6-TR42	EV306016	6-VR9
ED200468	9-D20,21	EI302233	6-IC2,3	ET307349	8-TR46	EV315540	6-VR11
ED200469	6-D22	EI302233	8-IC14,15	ET307349	9-TR17	EV315540	9-VR1
ED200469	7-D33to36	EI302409	7-IC2,3	ET308937	7-TR40,41	EV315541	6-VR4to6
ED200620	8-TH2,3	EI302409	8-IC3,4	ET308937	7-TR44,45	EV315541	6-VR10
ED300035	9-D6	EI302409	8-IC10	ET308937	7-TR48	EV315542	6-VR3
ED302269	6-D18	EI304657	9-IC2	ET316171	6-TR8	EV315542	6-VR7,8
ED302295	7-D14	EI306009	6-IC1	ET316171	6-TR14to19	EV319081	6-VR12
ED305704	8-D3	EI306009	6-IC7	ET316171	6-TR24to26	EV325331	6-VR1,2
ED305706	8-D19	EI306141	6-IC8	ET316171	6-TR28,29	EV464196	8-VR1
ED305750	8-TH1	EI310036	6-IC4	ET316171	6-TR37to41	EV464220	8-VR3
ED306010	9-D4	EI310036	8-IC8	ET316171	6-TR43	EV464231	8-VR4,5
ED306012	9-D2,3	EI317652	8-IC7	ET316171	6-TR60to63	EV464231	8-VR7
ED306013	9-D5	EI318384	8-X1	ET316171	6-TR66to68	EV522797	8-VR2
ED306014	9-D23	EI318922	8-IC1	ET316171	12-TR1,2	EV522797	8-VR9
ED306015	9-D10	EI319555	8-IC11	ET316643	7-TR66	EV523620	7-VR1
ED306109	6-D25	EI322993	8-IC9	ET317688	7-TR30,31	EV572433	8-VR6
ED306109	9-D12,13	EI324061	4-2	ET318125	9-TR19	EV572433	8-VR8
ED306316	9-D19	EI324668	14-D1	ET320296	6-TR57	EW306152	15-40x
ED306320	9-D22	EI325557	9-IC1	ET320296	8-TR47	EW306427	15-8x
ED306983	9-D9	EI325755	10-IC1	ET320296	9-TR10	EW315767	15-41x
ED307610	8-D23	EJ200618	7-J2	ET320296	9-TR11to15	EW322400	15-42x
ED308952	6-D2	EJ301513	15-6	ET391768	6-TR3	EW322401	15-43x

When ordering parts, please quote Parts Number, Description and Model Number.

# INDEX

PARTS NO.	REF. NO.	PARTS NO.	REF. NO.	PARTS NO.	REF. NO.	PARTS NO.	REF. NO.
EW328245	15-9x	ZG289236	2-2				
EZ329981	15-12x	ZG310531	4-22				
HE315742	2-6	ZG312926	5-4				
HPH2402A010A	2-11	ZG312942	4-25				
HZ309128	2-3	ZG312943	3-4				
HZ317352	2-10	ZG312943	4-24				
HZ317355	2-14	ZG312943	5-14				
MB282104	3-6	ZG312944	5-3				
MB282104	4-21	ZG312946	2-9				
MB323686	4-15	ZG312996	2-20				
MH306389	5-10	ZG313003	5-5				
MI321191	3-11	ZG313165	5-9				
MLB308406	3-8	ZG313187	2-5				
MLB318775	4-26	ZG317411	4-33				
ML306335	4-23	ZG317414	4-30				
MPB319580	4-28	ZG317429	3-5				
MRB306596	4-14	ZG317431	3-7				
MR306397	15-20	ZG321595	3-9				
MR310663	4-11	ZG330077	3-14				
MR320323	5-12	ZG465636	2-17				
MS302191	4-19	ZS300626	2-13				
MTB312122	3-16	ZS306435	17-34x				
MT305793	3-18	ZS306463	15-39				
MV269965	4-31	ZS310588	17-21x				
SA311742	15-38	ZS315686	17-12x				
SB315697	17-15	ZS315878	17-20x				
SB315698	17-16x	ZS317554	16-13				
SB316316	5-1	ZS325495	15-37				
SB316317	5-2x	ZS325495	15-7				
SB317625	16-3	ZS330073	3-17				
SB317626	16-4	ZS356804	2-15				
SB317627	16-5	ZS416687	15-4				
SB317628	16-6	ZS417227	2-7				
SB317629	16-7	ZS419782	2-19				
SB317630	16-8	ZS432843	3-20				
SB317631	16-9	ZS447761	15-25				
SB317633	16-10	ZS447761	17-22x				
SB317642	16-11x	ZS462947	2-16				
SK306765	17-25	ZS590804	2-18				
SK306771	17-26x	ZS608174	2-22				
SK306902	17-29	ZS613901	17-33				
SK306935	17-27	ZW241200	16-18x				
SK306964	17-28x	ZW259661	4-27				
SK329030	17-24x	ZW263946	6-3				
SK329031	17-23	ZW270088	3-3				
SK329034	17-30x	ZW270088	4-29				
SM315737	17-9	ZW270088	5-13				
SP306400A	17-7	ZW270101	4-32				
SP306400B	17-8x	ZW270123	2-8				
SP306540A	17-17x	ZW273756	4-18				
SP306540B	17-18x	ZW305013	17-35x				
SP306540	17-19x	ZW321437	4-16				
SP306544	15-36	ZW321703	4-17x				
SP306559A	15-22x	ZW357164	15-16				
SP306559B	15-23x	ZW357658	5-11				
SP306559C	15-24x	ZW391397	15-18				
SP306559D	15-21	ZW413267	15-5				
SZ306578	17-5	ZW432753	3-10				
SZ317672	2-21	ZW591265	2-4				
SZ631945	15-10x						
TA328841	15-13x						
TCT2018A040A	3-19						
TCT2018A080A	4-7						
TCT2018A370A	15-17						
TC302235	8-2						
TC306395A	15-14						
TC306395A	17-13x						
TC306395B	15-15x						
TC306395B	17-14x						
TC306545A	17-6x						
TC306545B	17-10x						
TC306591	17-11x						
TC309145	4-20						
TC309206	5-8						
TC315648	4-8						
TC317433	3-13						
TC317454	5-6						
TC317455	5-7						
TC318150	3-15						
TC328669	3-2						

---

SECTION 3

**SCHEMATIC DIAGRAM**

1. SCHEMATIC DIAGRAM OF ICs
2. GX-F95 NO. 3-1 1620842A POWER & SYSCON SCHEMATIC DIAGRAM
3. GX-F95 NO. 3-2 1620843A TUNING SCHEMATIC DIAGRAM
4. GX-F95 NO. 3-3 1620844A AMPLIFIER SCHEMATIC DIAGRAM

**AP-400A**

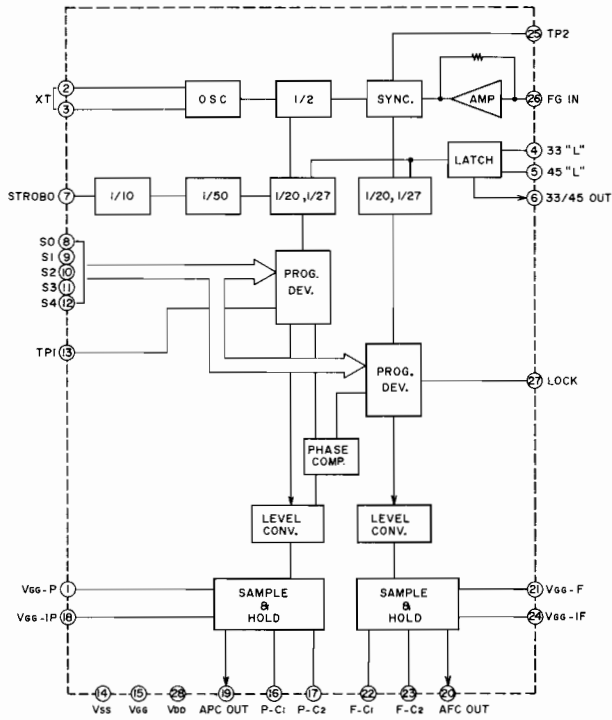

**HD74107P**

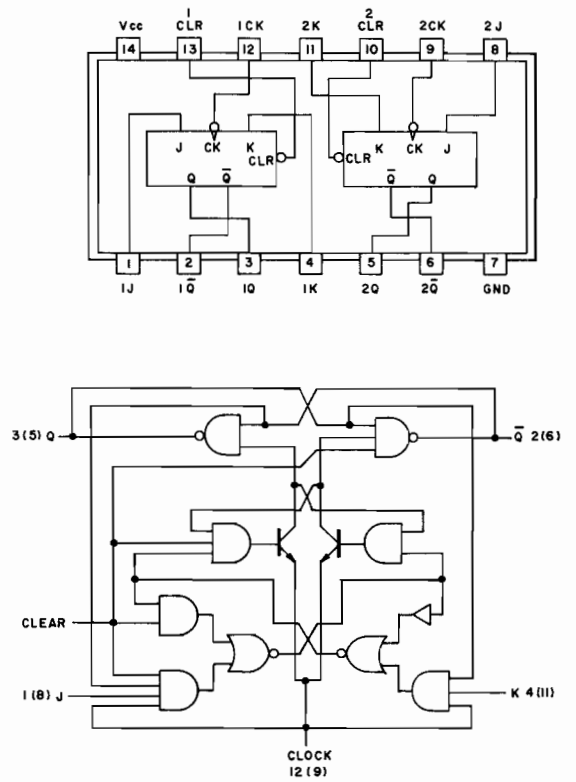

**HD7404P**

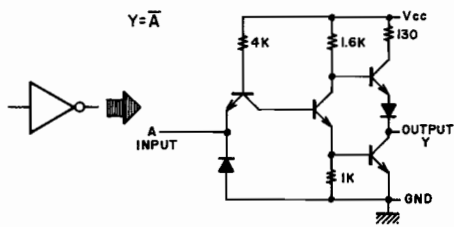
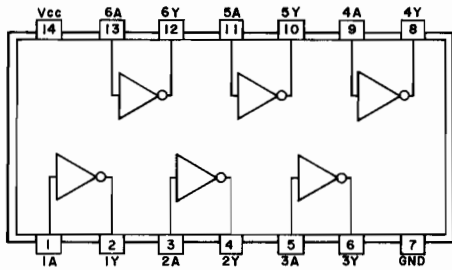

**HD74LS02P**

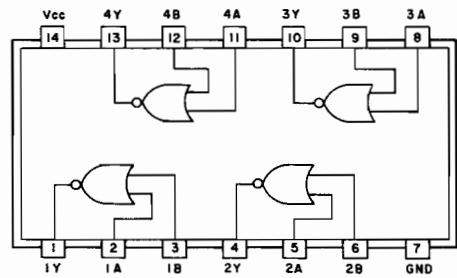

**LA4170**

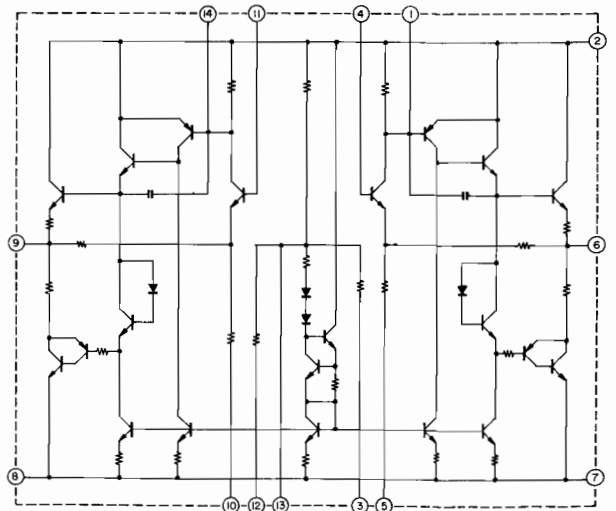

**HD7407P**

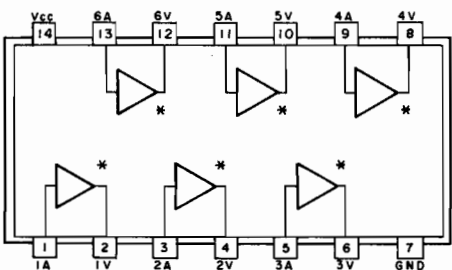

\* OPEN COLLECTOR

# MB8841M-373M/-424M

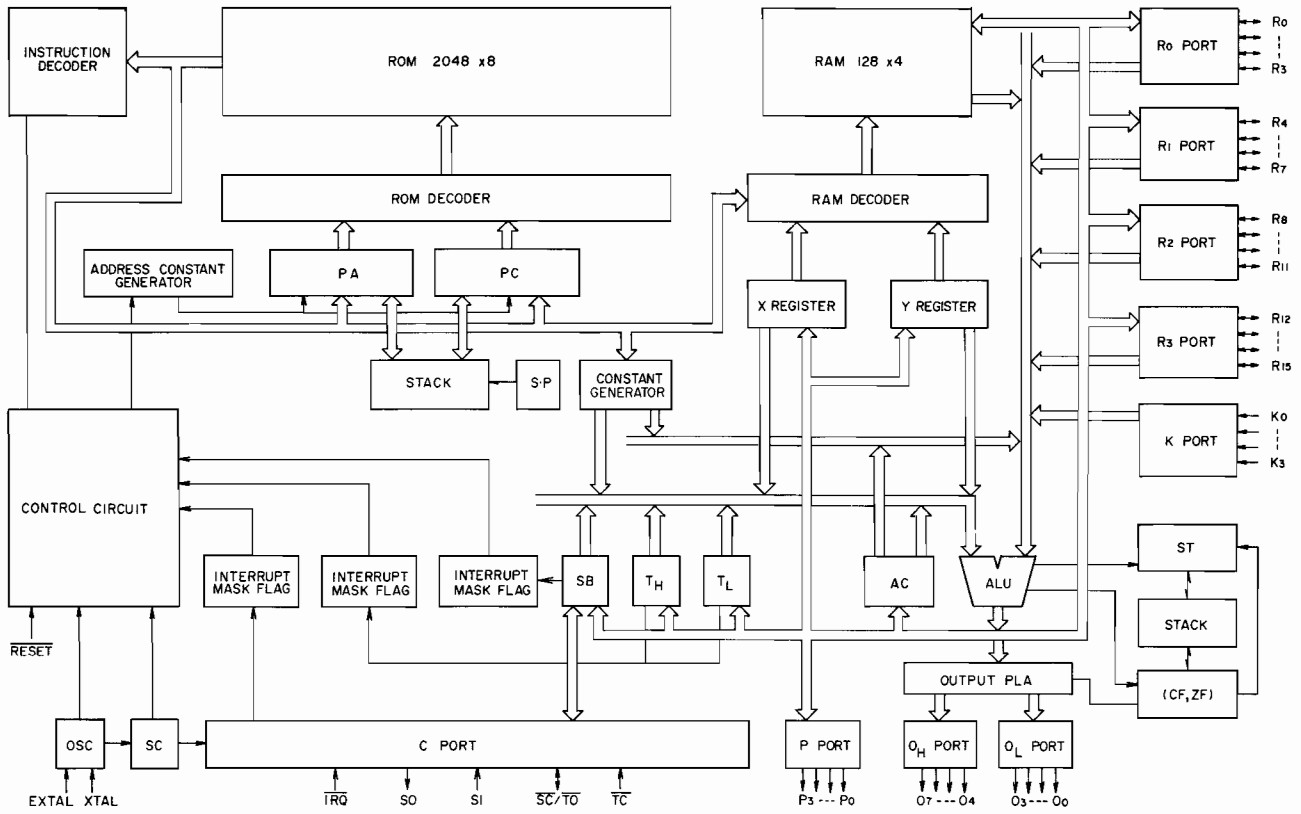

# LC7550

1 (EXTAL)	(Vcc) 42
2 (XTAL)	(K3) 41
3 (RESET)	(K2) 40
4 (TRQ)	(K1) 39
5 (SO)	(K0) 38
6 (SI)	(R15) 37
7 (SC/T0)	(R14) 36
8 (TC)	(R13) 35
9 (P0)	(R12) 34
10 (P1)	(R11) 33
11 (P2)	(R10) 32
12 (P3)	(R9) 31
13 (O0)	(R8) 30
14 (O1)	(R7) 29
15 (O2)	(R6) 28
16 (O3)	(R5) 27
17 (O4)	(R4) 26
18 (O5)	(R3) 25
19 (O6)	(R2) 24
20 (O7)	(R1) 23
21 (Vss)	(R0) 22

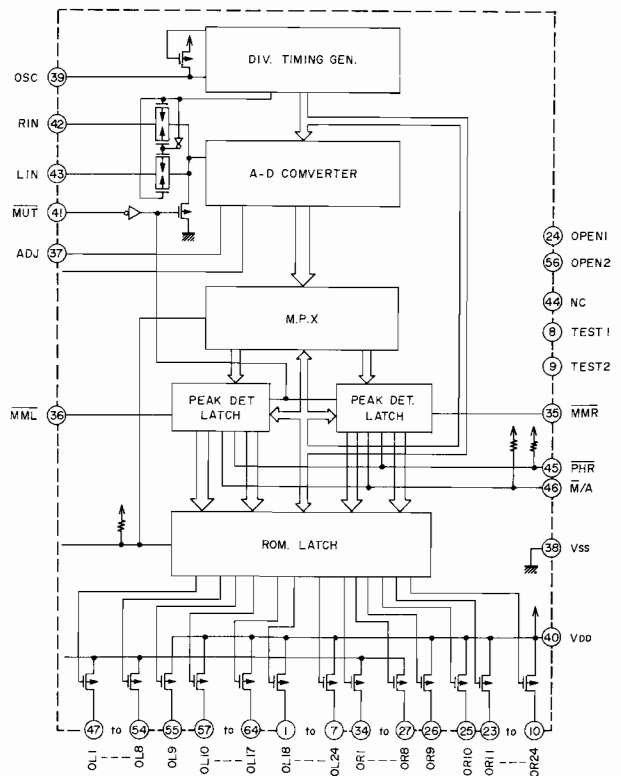

### LM-1111A

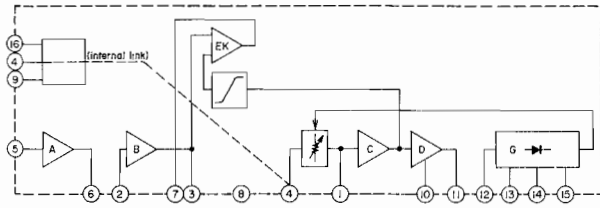

### NJM4558D

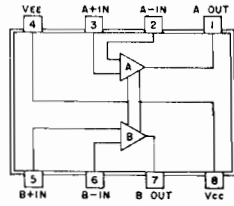

### TC4051BP

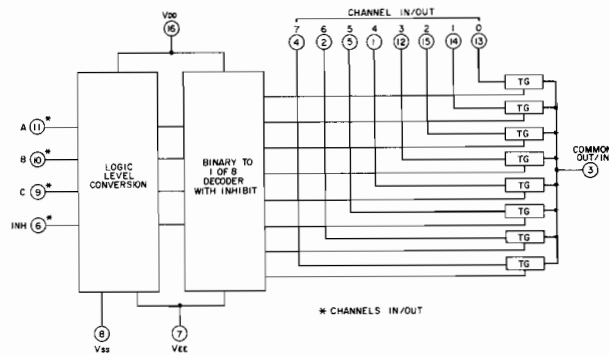

### TC4053BP

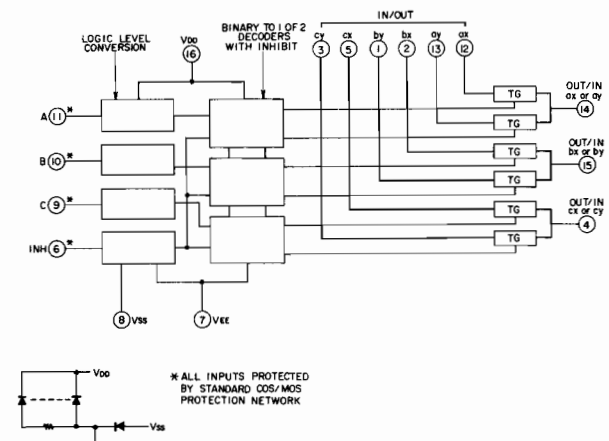

### TC4066BP

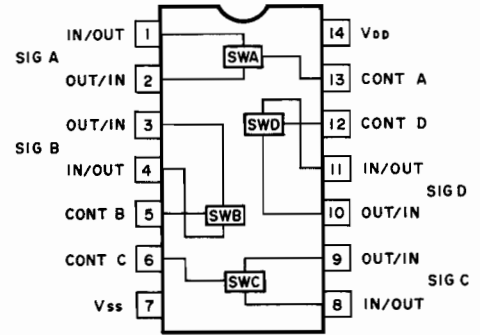

### TC4520BP

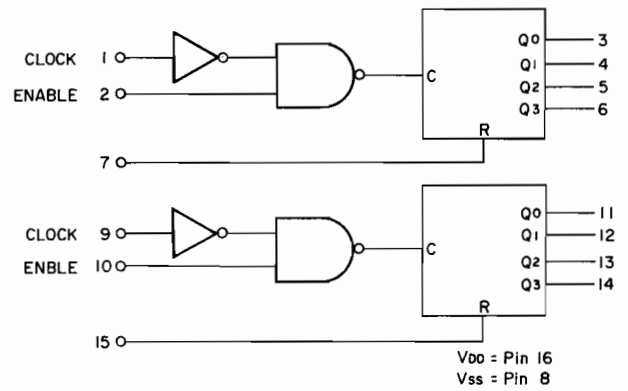

### μPC741C

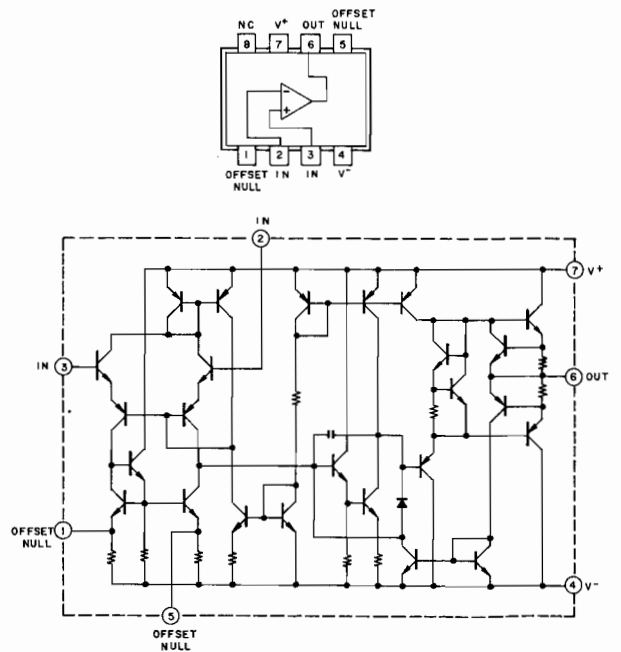



$\mu$ PC629C

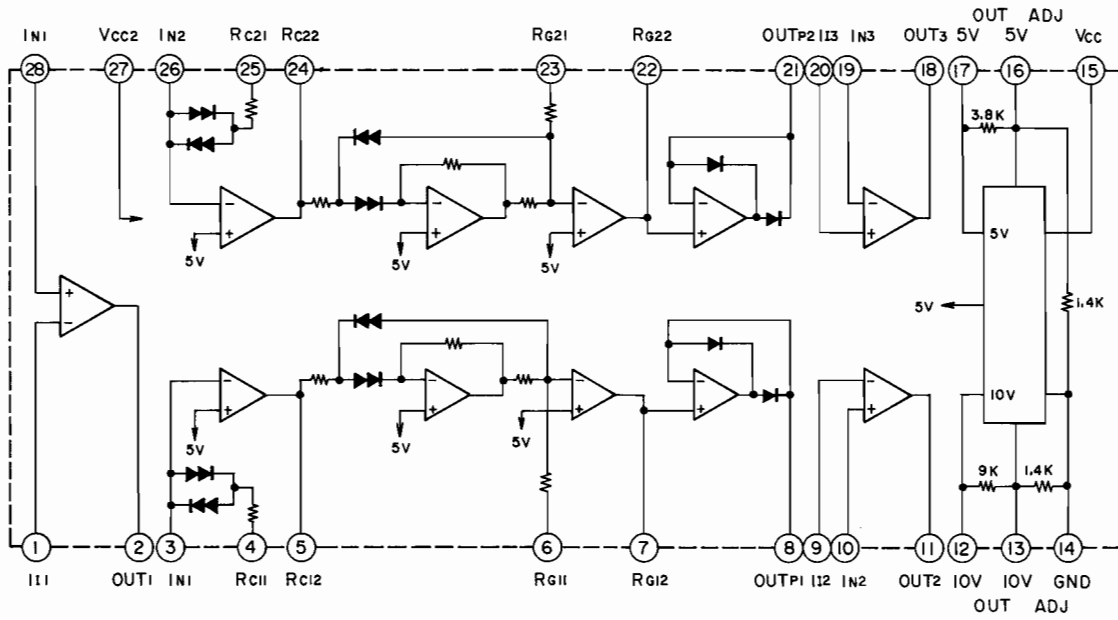

$\mu$ PD4049C

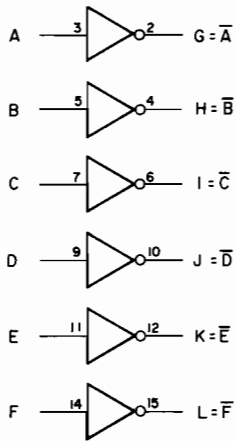

Vcc — 1 —  
 Vss — 8 —  
 NC = 13  
 NC = 16

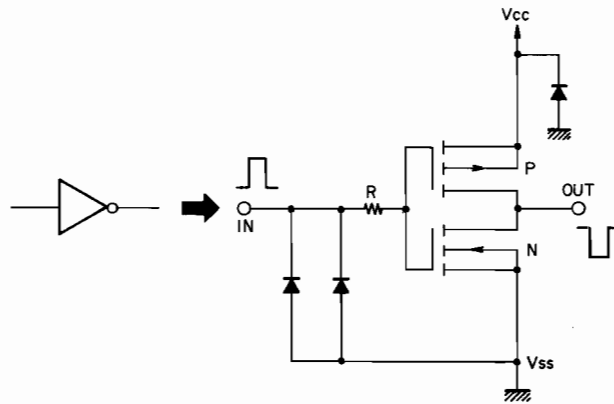

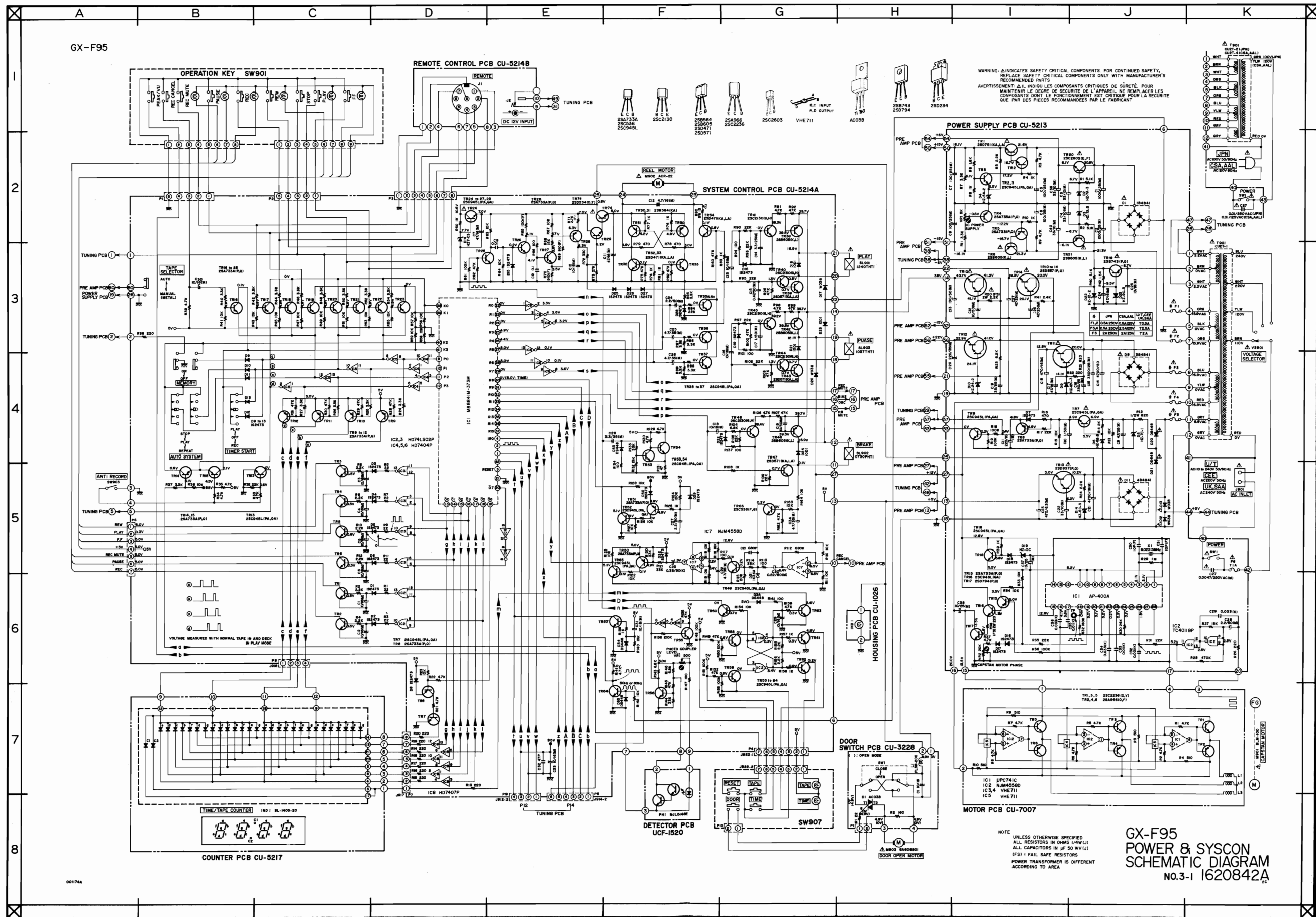

GX-F95  
POWER & SYSCON  
SCHEMATIC DIAGRAM  
NO.3-1 1620842A

GX-F95

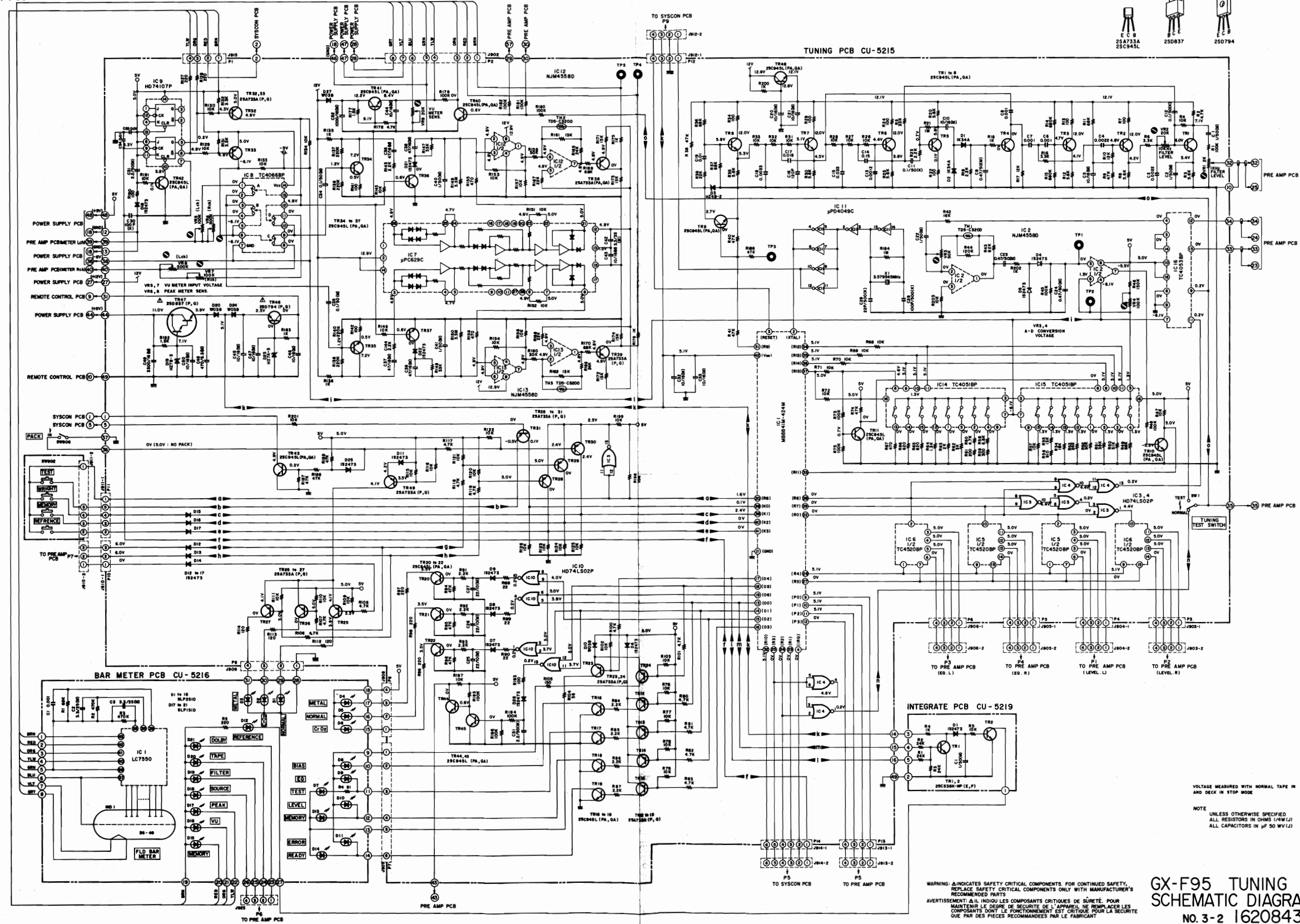

WARNING: Δ INDICATES SAFETY CRITICAL COMPONENTS. FOR CONTINUED SAFETY, REPLACE SAFETY CRITICAL COMPONENTS ONLY WITH MANUFACTURER'S RECOMMENDED PARTS.  
 AVERTISSEMENT: Δ IL INDIQUE LES COMPOSANTS CRITIQUES DE SÛRETÉ. POUR MAINTENIR LE DEGRÉ DE SÛRETÉ DE L'APPAREIL, NE REMPLACEZ LES COMPOSANTS DONT LE FONCTIONNEMENT EST CRITIQUE POUR LA SÛRETÉ QUE PAR DES PIÈCES RECOMMANDÉES PAR LE FABRICANT.

**GX-F95 TUNING SCHEMATIC DIAGRAM**  
 No. 3-2 1620843A

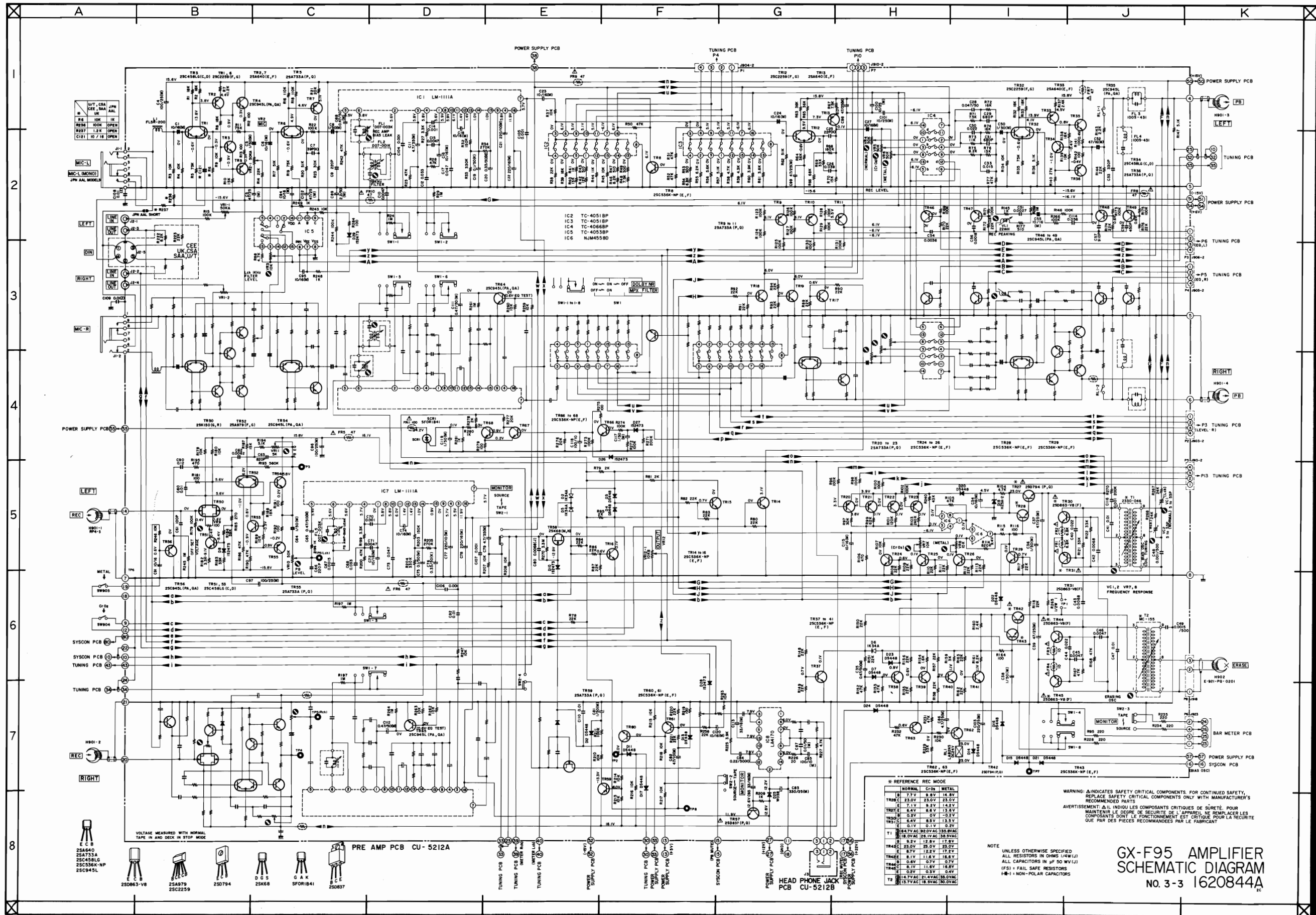

X REFERENCE REC MODE

	NORMAL	C/D	METAL
TR1	7.7V	8.8V	14.8V
TR2	23.0V	25.0V	32.0V
TR3	7.1V	8.2V	14.2V
TR4	6.4V	8.5V	13.5V
TR5	0.5V	0.1V	0.5V
TR6	6.4V	8.5V	13.5V
TR7	12.4V	11.4V	10.4V
TR8	13.7V	12.7V	11.7V
TR9	8.1V	11.8V	18.8V
TR10	0.6V	0.7V	0.7V
TR11	8.1V	11.8V	18.8V
TR12	0.2V	0.3V	0.4V
TR13	12.4V	11.4V	10.4V
TR14	13.7V	12.7V	11.7V

WARNING: INDICATES SAFETY CRITICAL COMPONENTS. FOR CONTINUED SAFETY, REPLACE SAFETY CRITICAL COMPONENTS ONLY WITH MANUFACTURER'S RECOMMENDED PARTS.  
 AVERTISSEMENT: AIL INDIQUE LES COMPOSANTS CRITIQUES DE SÛRETÉ. POUR MAINTENIR LE DEGRÉ DE SÛRETÉ DE L'APPAREIL, NE REMPLACER LES COMPOSANTS DONT LE FONCTIONNEMENT EST CRITIQUE QUE PAR DES PIÈCES RECOMMANDÉES PAR LE FABRICANT.

NOTE  
 UNLESS OTHERWISE SPECIFIED  
 ALL RESISTORS IN OHMS (1/4W/1%)  
 ALL CAPACITORS IN  $\mu$ F 50 WV(1%)  
 (FS) = FAIL SAFE RESISTORS  
 (N) = NON-POLAR CAPACITORS

**GX-F95 AMPLIFIER SCHEMATIC DIAGRAM**  
 NO. 3-3 1620844A